

doi: 10.18720/MCE.76.6

The deflection of spatial coatings with periodic structure

Прогиб пространственного покрытия с периодической структурой

M.N. Kirsanov,
National Research University "Moscow Power
Engineering Institute", Moscow, Russia

Д-р физ.-мат. наук, профессор
М.Н. Кирсанов,
Национальный исследовательский
университет "МЭИ", г. Москва, Россия

Key words: spatial truss; deflection; Maple;
analytical solution; coating

Ключевые слова: пространственная ферма;
прогиб; Maple; аналитическое решение; покрытие

Abstract. The scheme of the statically determinate spatial truss is proposed. Rectangular truss has a vertical supports on the sides and loaded uniformly at the nodes by the vertical forces. The forces in the rods and supports are determined using cut nodes method. The dependence of the deflection mid-span on a number of panels is obtained. A generalization of the particular solutions on an arbitrary number of panels obtained by the method of induction. All transformations and solutions are made in the system of computer mathematics Maple. The homogeneous linear recurrence equation satisfied by the members of the sequence of coefficients of the desired formula are derived and solved using the special operators of Maple. The formula for deflection is polynomial type in the number of panels. Plots of the deflection of the number of panels, height and the distribution ratio of cross-sectional areas of the rods are given. Expression of forces in the most stretched and compressed rods are obtained to perform durability and structural stability. The found solutions can be used by practical engineers to assess the performance of the designed construction and its optimization.

Аннотация. Предложена схема статически определимой пространственной фермы. Прямоугольная в плане ферма имеет вертикальные опоры по боковым сторонам и равномерно нагружена в узлах вертикальной нагрузкой. Усилия в стержнях и опорах определяются методом вырезания узлов. Найдена зависимость прогиба середины пролета от числа панелей. Обобщение частных решений на произвольное число панелей получено методом индукции. Все преобразования и решения выполнены в системе компьютерной математики Maple. С помощью специальных операторов Maple выводятся и решаются однородные линейные рекуррентные уравнения, которым удовлетворяют члены последовательностей коэффициентов искомой формулы. Полученная формула для прогиба имеет полиномиальный по числу панелей характер. Построены графики зависимости прогиба от числа панелей, от высоты и от коэффициента распределения площадей поперечных сечений в стержнях. Применительно к анализу прочности и устойчивости конструкции найдены выражения для усилий в наиболее растянутых и сжатых стержнях. Найденные решения могут быть использованы практическими инженерами для оценки работоспособности проектируемой конструкции и для ее оптимизации.

Introduction

One of the urgent problems of structural mechanics is the problem of overlap in large areas. This is required in the construction of hangars for aircraft, modern shopping centers, airports and concert halls. Known variants of the coatings in the form of hanging structures [1–4], the overlap in the membrane [5, 6]. As one of the most simple and easily implemented solutions to cover large areas without the use of intermediate supports is the use of lightweight trusses [7–11].

In this paper, we design and analytical calculation of truss (Fig. 1). The design consists of several gable trusses connected along the long sides. Statically determinate truss with $2n$ panels on one side and $2m$ on the other contains $n_s = 3(4mn + 2m + 2n + 1)$ rods, including three rods, forming a spherical bearing *A* and cylindrical *B*. At the sides of the truss located $4(m + n)$ vertical support legs with a length h and $h+c$ (Figs. 2,3). Truss consist $2n(2m+1)$ horizontal rod *a* long, $4mn$ bracing of length $d = \sqrt{a^2 + b^2 + h^2}$ and $2m(2n+1)$ inclined struts of length $g = \sqrt{b^2 + h^2}$.

Кирсанов М.Н. Прогиб пространственного покрытия с периодической структурой // Инженерно-строительный журнал. 2017. № 8(76). С. 58–66.

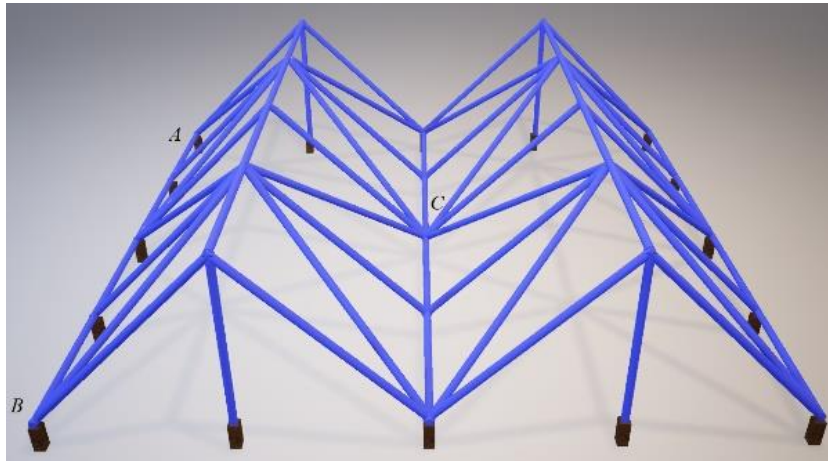

Figure 1. 3D model of the truss, $n = m = 2$

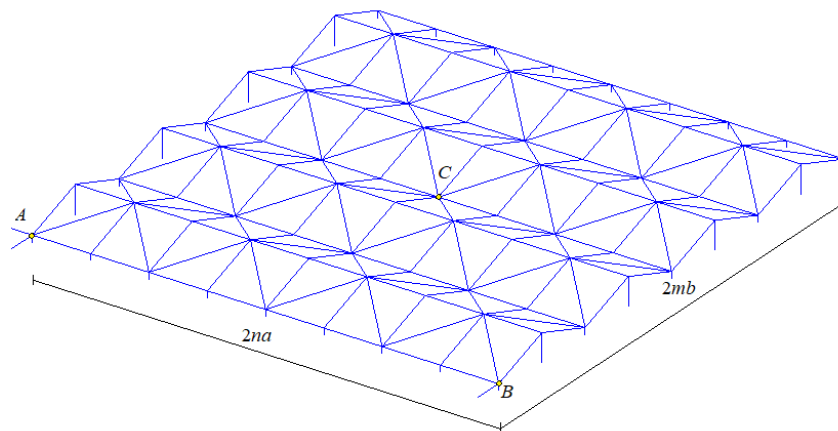

Figure 2. The scheme of the truss, $m = n = 4$

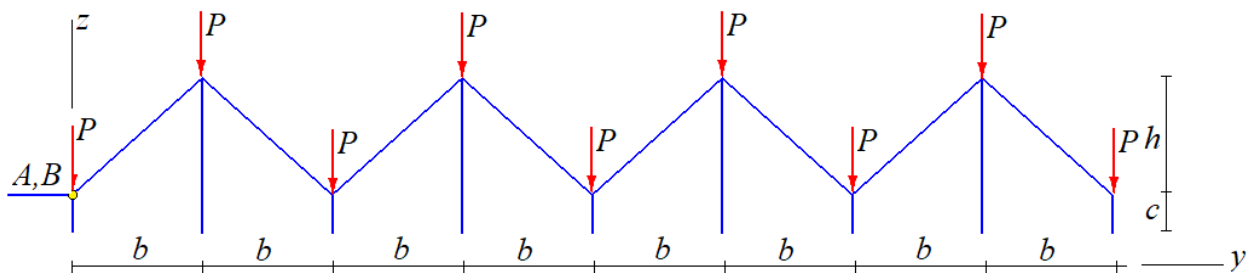

Figure 3. Truss and load in plane $y - z$, $m=4$

The calculation of the stresses in the rods

The task is to find the analytic dependence of the deflection of the panels under uniform loading of a truss in the joints. A mathematical model of truss has been built in the system of analytical transformations Maple [12]. A similar problem for statically determinate rectangular cover with four nodes in the corners of the structure and an arbitrary number of panels is decided by the author [13, 14]. The analytical dependence of the spatial deflection of the cantilever truss on a number of panels is found in [15]. Beam spatial truss with the construction rise is investigated in an analytical form in [16].

The program [12] is used to determine the stresses in the bars. The algorithm is based on the method of cutting nodes in symbolic form. Therefore, it allows applying the method of induction to generalize the solution for an arbitrary number of panels. The program introduces the coordinates of the nodes of the core mesh

$$x_k = a(i-1), y_k = b(j-1), z_k = 0, k = i + (j-1)(2n+1), i = 1, \dots, 2n+1, j = 1, \dots, 2m+1, \quad (1)$$

$$z_{i+(2j-1)(2n+1)} = h, i = 1, \dots, 2n+1, j = 1, \dots, m.$$

The order of connection of rods and nodes (joints) is set by the special vectors containing the numbers of the rods ends. Orthogonal mesh of coating is specified, for example, by vectors

$$V_{i+2n(j-1)} = [i + (j-1)(2n+1), i + (j-1)(2n+1) + 1], i = 1, \dots, 2n, j = 1, \dots, 2m+1,$$

$$V_{i+u+2m(j-1)} = [j + (2n+1)(i-1), j + (2n+1)i], u = 2n(2m+1), i = 1, \dots, 2m, j = 1, \dots, 2n+1.$$

Similarly, the braces and support legs are encoded. The matrix of equilibrium equations of the nodes is formed of the guides of the cosines of forces, determined based on the given geometry of the structure and the order of connection of terminals [13–16]. The rows of the matrix with numbers $3i-2, i=1, \dots, n_s$ corresponding to a projection of the efforts on the axis of x . The rows $3i-1$ correspond to the projections on the y -axis; rows $3i$ are the projection on a vertical z -axis. The load (vertical force P) is applied at all nodes of the truss. The right part of the system of equilibrium equations is a vector $B_{3i} = -P, i = 1, \dots, (2n+1)(2m+1)$. The solution of the system equations in symbolic form with specified numbers of panels m and n gives the forces in all members (including supporting members) of the respective truss. Reactions of supports of the vertical struts along the longitudinal side length $2na$ do not depend on the number of panels m the transverse direction: $R_a = -(2n+1)P/2$. This dependence turned out the simplest generalization of the solutions for $n=1, 2, 3, \dots$. The reactions of the supports along the lateral sides do not depend on the number n : $R_b = -P$. These supports take the vertical load applied to the corresponding node. The reactions of horizontal connections in the corner hinge A and hinge B equal to zero.

For the calculation of the stability of rods in the truss according to the calculations of forces in rods with different numbers of panels on the sides of the structure one can be obtained the function of efforts in the most compressed and stretched rods from the values of n and m . Here depending on the parity of m longitudinal horizontal rods in the middle of the span, connected with the Central node in the truss will either be compressed or stretched. For even n these rods are in the stretched lower zone (Figs. 1, 2, 4). These values are independent of number m , and the dependence of the number of longitudinal panels n revealed by induction with the help of operators *rgf_findrecur* and *rsolve* of Maple [11-16]: $S^{(+)} = P(2n^2 - 1 - (-1)^n)a / (2h)$, $m=2k$. For odd m (Fig. 5) the corresponding rods are at the top of the truss, and they are compressed, and also the efforts do not depend on $m > 1$. The dependence of the number n has the form $S^{(-)} = -P(2n^2 + (-1)^n - 1)a / (2h)$. Transverse oblique bars (Figs. 4, 5) connected to the central node, depending on the parity of n are compressed or stretched at any values of m : $T = -(-1)^n Pg / (2h)$.

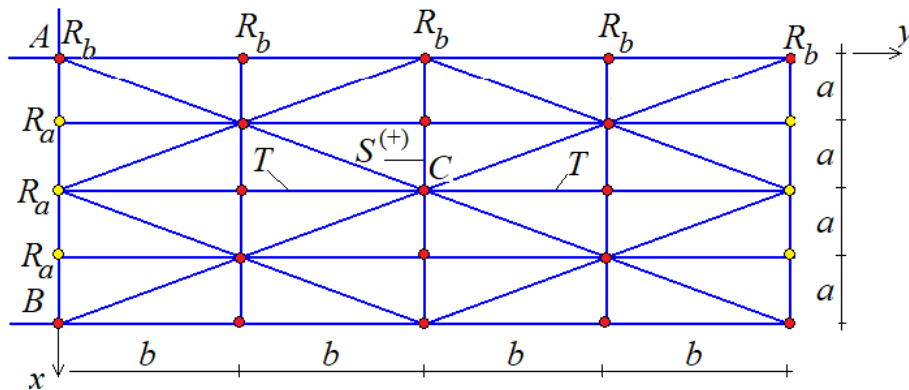

Figure 4. The forces in the rods and the support reaction for the even numbers $m, (n = 2, m = 2)$

Curves of the dimensionless deflection of the panels (Fig. 6) in the condition of the constancy of the span construction $L = 60m$, $b = a = L / (2n)$, and the total load to the truss $P_{sum} = (2n + 1)^2 P$ show almost monotonous decrease of the deflection with increasing number of panels. Given the notation: $\Delta_1' = \Delta_1 EF / (P_{sum} L)$.

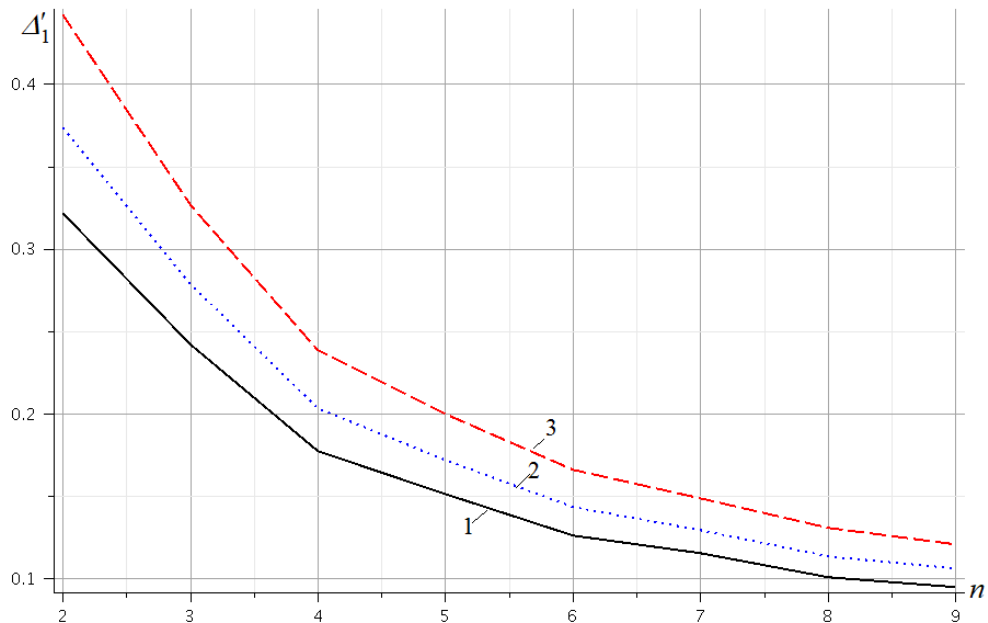

Figure 6. The dependence of the deflection of the panels.
 1 – $h = 12m$, 2 – $h = 11m$, 3 – $h = 10m$

The dependence of the deflection of the height of the truss (in the previous assumptions on the total load and length of span) is more complicated. At sufficiently high altitudes of the truss, curves reveal the minimum (Fig. 7). This fact can be used to optimize stiffness. Analytical expressions for the minimum value cannot be obtained. Simple numerical calculations by formula (3) show that with the increase in the number of panels the critical height decreases.

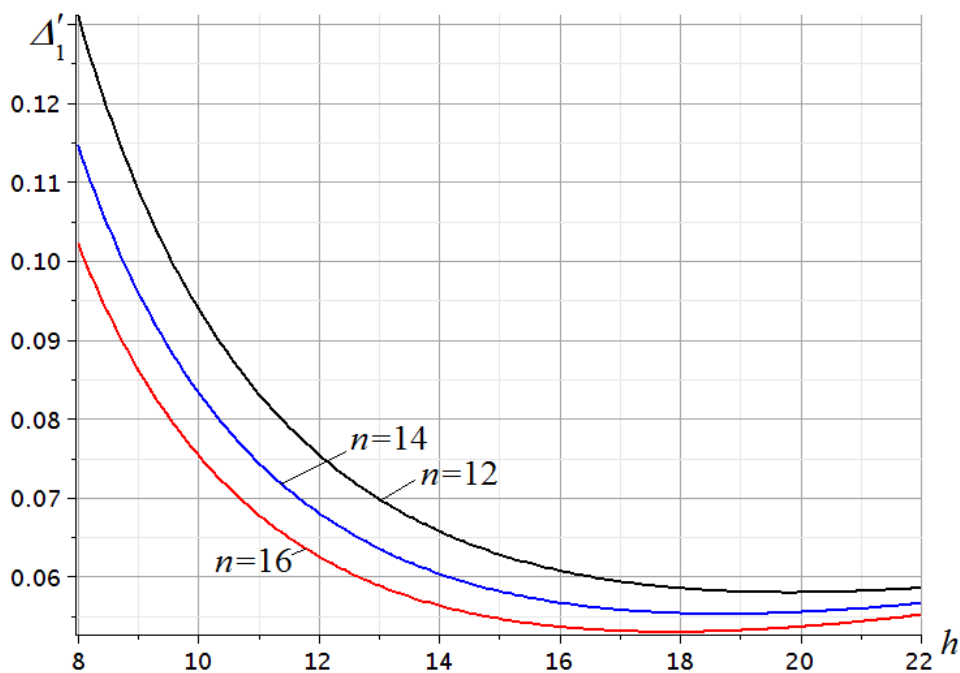

Figure 7. The dependence of the deflection of the height

The effect of the gain of the cross sections of the support racks on the solution is shown in the curves in Figure 8. An interesting and unexpected effect of the intersection of the curves was found for different numbers of panels.

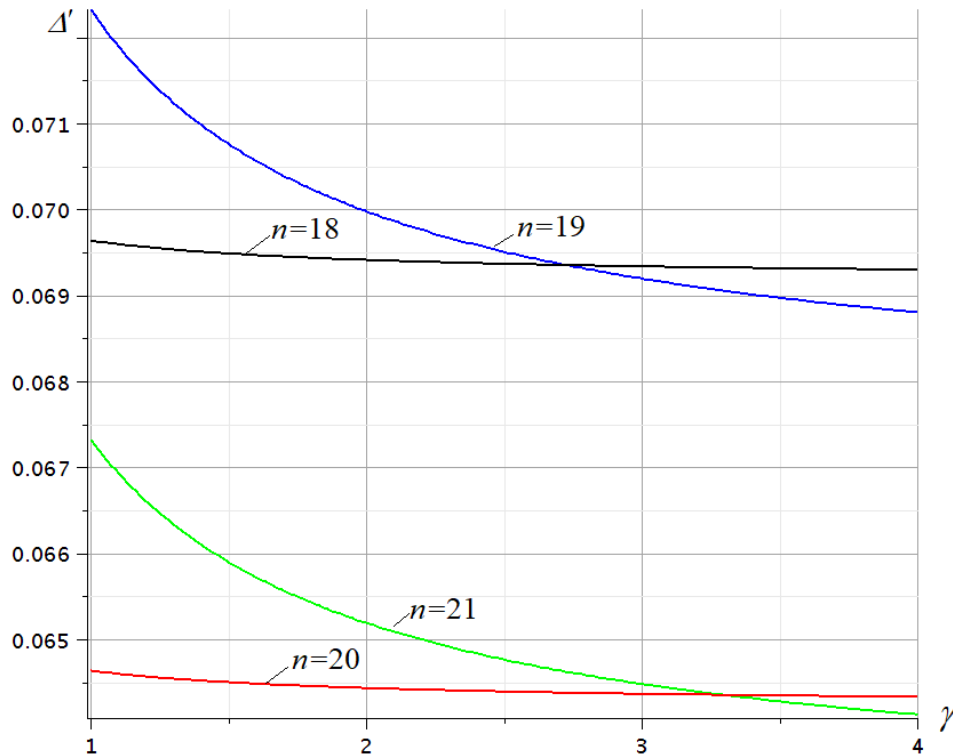

Figure 8. Dependence of the deflection on the cross-section ratio, $h = 10$ m, $L = 60$ m

We also give a formula for deflecting a truss from the action of one concentrated force in the central hinge C

$$\Delta_3 = P \left((n^3 a^3 + n d^3 + (1 - (-1)^n) g^3 / 2) / h^2 + (2c + h(1 - (-1)^n)) / \gamma \right) / (4EF). \quad (5)$$

To derive this formula, it was sufficient to use the values of the forces s_j obtained from the action of the unit force used in the derivation of the solution (3). The coefficients here turned out to be quite simple, and the operators of the Maple system did not need to compile and solve recurrence equations. The check of the analytical dependencies (3), (4) and (5) was carried out for different values of n according to the same program [12] but in the numerical mode. The speed of numerical transformations in Maple is inferior to specialized programs based on the finite element method, but it is an order of magnitude higher than the rate of symbolic transformations. It is this feature of the symbolic transformations, which does not allow directly obtaining a formula of the form (3) for large numbers of panels, that has caused the development of inductive methods. From the practice of calculating spatial trusses, it was noted that as the number of panels increases, the time of symbolic transformations grows faster than the geometric sequence. If seconds are required to obtain the formula (3) for $n = 2$ with integer coefficients $C_{1,n}$, $C_{2,n}$, $C_{3,n}$ necessary for the initial conditions of the corresponding recurrent equations, then the solution of the same problem for $n = 9$ requires the operating hours of the computer with a high-speed processor i7 and 16 GB memory. However, in this problem, an interesting move has been found that makes it possible to shorten the time of obtaining a sequence with a length sufficient to reveal its common term. It turned out that for $C_{2,n}$, $C_{3,n}$ simpler formulas are obtained based on the calculation of only six trusses with $n = 2, \dots, 7$, while the lengths of the corresponding sequence of coefficients $C_{1,n}$ are still insufficient to obtain a common term. The *rgf_findrecur* operator does not give a recursive equation for $C_{1,n}$ if the sequence is not long enough. Therefore, it was decided to obtain a sequence of solutions in a numerical mode that is practically unlimited in counting speed, and subtract the terms $C_{2,n}d^3$ and $C_{3,n}g^3$ from the obtained numerical values of the deflection, and formulas for the

coefficients in which have already been obtained. If we take $a = 1$ in this numerical experiment, then the difference found just gives the coefficient $C_{1,n}$ for $n = 2, \dots, 10$. After this, with the involvement of the operator, one can obtain the desired common term.

Results and Discussion

In [17, 18] R.G. Hutchinson and N.A. Fleck announced the "hunt" for schemes of statically determinate periodic trusses. The number of such constructions is limited [19, 20]. In this paper, we propose new scheme of a spatial construction of this type. The advantages of analytical calculations of such trusses are obvious. By changing only one parameter in the solution, one can obtain and analyze solutions for a fairly wide class of constructions. Sometimes when analyzing such solutions, hidden and quite dangerous features of the trusses are found. For example, in [11] it was found that for an even number of panels the truss becomes a kinematically variable mechanism. The investigated truss (Fig. 1) does not possess similar features, however, when the shape of the surface $z = z(i, j)$ given by function (1) changes, one can obtain the case when the determinant of the system of equations becomes zero. In particular, this is possible if all rods connected to a node are in the same plane. In this case, the load on the node perpendicular to the plane of the rods can not be balanced. We note that it is the easiest method to discover the unique features of the construction and to outline the ways of its optimization from the formal representation of the result. It is the direction of the research chosen by the author and his students [20–23]. Another direction in analytical research can be the solution to problems based on the symbolic form of equilibrium equations or equations of the finite element method. This method has the right to exist, especially for solving problems for irregular (non-periodic) systems. However, it is not possible to obtain any closed compact formulas suitable for analysis and practical use [24]. In [25–27] simple semi-empirical approximate formulas are proposed for the calculation of flat and spatial trusses. It is possible that the linear formulation of the problem, adopted in analytical calculations, does not always yield exact solutions. Non-linear analysis of the trusses [28] is usually performed numerically, but some algorithms used in this study can be useful for a non-linear statement of the problem.

Conclusions

A new periodic core structure of the spatial coverage is proposed and analytically investigated. A formula has been obtained for the dependence of the deflection in the middle part of the span on the number of panels. The solution found, in addition to the magnitude of the load and the characteristics of the material, contains five geometric parameters describing the dimensions and shape of the structure. Therefore, it allows us to apply the desired formula for a fairly wide class of similar trusses, both for a simple estimation of the possibilities of the construction and for testing the numerical solutions found possible with a more general formulation of the problem. The applied algorithm of modeling the cover with supports along its entire perimeter makes it possible to easily generalize the form of the coating to some more complex, possibly non-periodic, surface. However, in this case, the possibility for an analytical calculation of deflection and effort disappears. The experience of modeling and experiments in the Maple system in this direction showed that not all surfaces, even periodic ones, allow the use of the induction method. The limitation here is the time of symbolic transformations. Transformations lasting more than a day and with a result in the form of a formula per page or more lose their practical meaning. Facilities with these properties make sense to calculate numerically, obtaining particular solutions for each specific case

References

1. Kirsanov N.M. *Visyachiye pokrytiya proizvodstvennykh zdaniy* [Hanging covers of industrial buildings]. Moscow: Stroyizdat. 1990. 128 p. (rus)
2. Sophianopoulos D.S., Michaltsos G.T. Nonlinear stability of a simplified model for the simulation of double suspension roofs. *Engineering Structures*. 2001. Vol. 23. No. 6. Pp. 705–714.
3. Diord S., Magalhaes F., Cunha A., Caetano E. High spatial resolution modal identification of a stadium suspension roof: Assessment of the estimates uncertainty and of modal contributions. *Engineering Structures*. 2017. Vol. 135. No. 15. Pp. 117–135.
4. Pyl L., Sitters C.W.M., De Wilde W.P. Design and optimization of roof trusses using morphological indicators. *Advances in Engineering Software*. 2013. Vol. 62–63. No. 8–9. Pp. 9–19.
5. Shimanovskiy A.V., Tsykhanovskiy V.K. *Teoriya i raschet*

Литература

1. Кирсанов Н.М. Висячие покрытия производственных зданий. М.:Стройиздат, 1990. 128 с.
 2. Sophianopoulos D.S., Michaltsos G.T. Nonlinear stability of a simplified model for the simulation of double suspension roofs // *Engineering Structures*. 2001. Vol. 23. №6. Pp. 705–714.
 3. Diord S., Magalhaes F., Cunha A., Caetano E. High spatial resolution modal identification of a stadium suspension roof: Assessment of the estimates uncertainty and of modal contributions // *Engineering Structures*. 2017. Vol. 135. Pp. 117–135.
 4. Pyl L., Sitters C.W.M., De Wilde W.P. Design and optimization of roof trusses using morphological indicators // *Advances in Engineering Software*. 2013. Vol. 62–63. Pp. 9–19.
 5. Шимановский А.В., Цыхановский В.К. Теория и расчет
- Кирсанов М.Н. Прогиб пространственного покрытия с периодической структурой // *Инженерно-строительный журнал*. 2017. № 8(76). С. 58–66.

- silnonelineynykh konstruktsiy* [The theory and analysis of nonlinear structures]. Kiev: Izd-vo "Stal". 2005. 432 p. (rus)
6. Mushchanov V., Gorokhov Y., Vardanyan A., Kashchenko M., Nemova D. Particular features of calculation and design of long-span membrane roofs. *Procedia Engineering*. 2015. Vol. 117. Pp. 990–1000.
 7. Cai J., Feng J., Jiang C. Development and analysis of a long-span retractable roof structure. *Journal of Constructional Steel Research*. 2014. Vol. No. 1. Pp. 175–182.
 8. Guo Y.-L., Zhao S.-Y., Dou C., Pi Y.-L. Out-of-plane strength design of spatially trussed arches with a rectangular lattice section. *Journal of Constructional Steel Research*. 2013. Vol. 88. No. 9. Pp. 321–329.
 9. Guo Y.L., Zhou P., Wang M.Z., Pi Y.L., Bradford M.A., Tong J.Z. Experimental and numerical studies of hysteretic response of tripletruss-confined buckling-restrained braces. *Engineering Structures*. 2017. Vol. 148. No. 1. Pp. 157–174.
 10. Nasrollahi A. Optimum shape of large-span trusses according to AISC-LRFD using Ranked Particles Optimization. *Journal of Constructional Steel Research*. 2017. Vol. 134. Pp. 92–101.
 11. Kirsanov M.N. Raschet prostranstvennoy sterzhnevoy sistemy, dopuskayushchey mgnovennuyu izmenyayemost [Calculation of spatial bar system that permits variability of instantly]. *Stroitel'naya mekhanika i raschet sooruzheniy*. 2012. No. 3. Pp. 48–51. (rus)
 12. Kirsanov M. N. *Maple i Maplet. Resheniya zadach mekhaniki* [Maple, and Maplet. Solving mechanics problems]. Saint Petersburg. Izd-vo Lan'. 2012. 512 p. (rus)
 13. Kirsanov M. N. Stress State and Deformation of a Rectangular Spatial Rod Cover. *Scientific Herald of the Voronezh State University of Architecture and Civil Engineering. Construction and Architecture*. 2016. Vol. 31. No. 3. Pp. 71–79.
 14. Kirsanov M. N. Analysis of the buckling of spatial truss with cross lattice. *Magazine of Civil Engineering*. 2016. No. 4. Pp. 52–58.
 15. Domanov Ye. V. Analiticheskaya zavisimost progiba prostranstvennoy konsoli treugolnogo profilya ot chisla paneley [The analytical dependence of the deflection spatial console triangular profile of the number of panels]. *Science Almanac*. 2016. No. 6-2(19). Pp. 214–217. (rus)
 16. Larichev S. A. Induktivnyy analiz vliyaniya stroitel'nogo podyema na zhestkost prostranstvennoy balochnoy fermy [Inductive analysis of the impact of the construction hoist on the spatial stiffness of a girder]. *Trends in Applied Mechanics and Mechatronics*. Moscow: Infra-M. 2015. Vol. 1. Pp. 4–8. (rus)
 17. Hutchinson R. G., Fleck N.A. Microarchitected cellular solids – the hunt for statically determinate periodic trusses. *ZAMM Z. Angew. Math. Mech*. 2005. Vol. 85. No. 9. Pp. 607–617.
 18. Hutchinson R.G., Fleck N.A. The structural performance of the periodic truss. *Journal of the Mechanics and Physics of Solids*. 2006. Vol. 54. No. 4. Pp. 756–782.
 19. Zok F.W., Lattice R.M., Begley M.R. Periodic truss structures. *Journal of the Mechanics and Physics of Solids*. 2016. Vol. 96. Pp. 184–203.
 20. Tinkov D.V. Srovnitelnyy analiz analiticheskikh resheniy zadachi o progibe fermennykh konstruktsiy [Comparative analysis of analytical solutions to the problem of truss structure deflection]. *Magazine of Civil Engineering*. 2015. No. 5. Pp. 66–73. (rus)
 21. Tinkov D.V. Analiz vliyaniya usloviy zakrepleniya na progib ploskoy balochnoy fermy s niskhodyashchimi raskosami [Analysis of the influence of the fixing conditions for the deflection of a flat beam truss with down braces]. *Trends in Applied Mechanics and Mechatronics*. Moscow: Infra-M. 2015. Vol. 1. Pp. 52–56.
 22. Smirnova A.A., Rakhmatulina A.R Analytical calculation of the displacement of the truss support. *Science Almanac*. 2017. No. 2-3(28). Pp. 275–278.
 23. Rakhmatulina A.R., Smirnova A.A. The dependence of the deflection of the arched truss loaded on the upper belt, on the
 - сильнонелинейных конструкций. К.: Изд-во "Сталь", 2005. 432 с. (rus)
 6. Mushchanov V., Gorokhov Y., Vardanyan A., Kashchenko M., Nemova D. Particular features of calculation and design of long-span membrane roofs // *Procedia Engineering*. 2015. Vol. 117. Pp. 990–1000.
 7. Cai J., Feng J., Jiang C. Development and analysis of a long-span retractable roof structure // *Journal of Constructional Steel Research*. 2014. Vol. 92. Pp. 175–182.
 8. Guo Y.-L., Zhao S.-Y., Dou C., Pi Y.-L. Out-of-plane strength design of spatially trussed arches with a rectangular lattice section // *Journal of Constructional Steel Research*. 2013. Vol. 88. Pp. 321–329.
 9. Guo Y.L., Zhou P., Wang M.Z., Pi Y.L., Bradford M.A., Tong J.Z. Experimental and numerical studies of hysteretic response of tripletruss-confined buckling-restrained braces // *Engineering Structures*. 2017. Vol. 148. Pp. 157–174.
 10. Nasrollahi A. Optimum shape of large-span trusses according to AISC-LRFD using Ranked Particles Optimization // *Journal of Constructional Steel Research*. 2017. Vol. 134. Pp. 92–101.
 11. Кирсанов М.Н. Расчет пространственной стержневой системы, допускающей мгновенную изменяемость // *Строительная механика и расчет сооружений*. 2012. № 3. С. 48–51.
 12. Кирсанов М.Н. *Maple и Maplet. Решения задач механики*. СПб.: Изд-во Лань, 2012. 512 с. (rus)
 13. Kirsanov M. N. Stress State and Deformation of a Rectangular Spatial Rod Cover // *Scientific Herald of the Voronezh State University of Architecture and Civil Engineering. Construction and Architecture*. 2016. Vol. 31. № 3. Pp. 71–79.
 14. Кирсанов М.Н. Анализ прогиба фермы пространственного покрытия с крестообразной решеткой // *Инженерно-строительный журнал*. 2016. № 4(64). С. 52–58.
 15. Доманов Е.В. Аналитическая зависимость прогиба пространственной консоли треугольного профиля от числа панелей // *Научный альманах*. 2016. № 6-2(19). С. 214–217.
 16. Ларичев С.А. Индуктивный анализ влияния строительного подъема на жесткость пространственной балочной фермы // *Trends in Applied Mechanics and Mechatronics*. М: Инфра-М. 2015. Т. 1. С. 4–8.
 17. Hutchinson R.G., Fleck N.A. Microarchitected cellular solids – the hunt for statically determinate periodic trusses // *ZAMM Z. Angew. Math. Mech*. 2005. Vol. 85. № 9. Pp. 607–617.
 18. Hutchinson R.G., Fleck N.A. The structural performance of the periodic truss // *Journal of the Mechanics and Physics of Solids*. 2006. Vol. 54. № 4. Pp. 756–782.
 19. Zok F.W., Lattice R.M., Begley M.R. Periodic truss structures // *Journal of the Mechanics and Physics of Solids*. 2016. Vol. 96. Pp. 184–203.
 20. Тиньков Д.В. Сравнительный анализ аналитических решений задачи о прогибе ферменных конструкций // *Инженерно-строительный журнал*. 2015. № 5(57). С. 66–73.
 21. Тиньков Д.В. Анализ влияния условий закрепления на прогиб плоской балочной фермы с нисходящими раскосами // *Trends in Applied Mechanics and Mechatronics*. М: Инфра-М. 2015. Т. 1. С. 52–56.
 22. Smirnova A.A., Rakhmatulina A.R Analytical calculation of the displacement of the truss support // *Научный альманах*. 2017. № 2-3(28). С. 275–278.
 23. Rakhmatulina A.R., Smirnova A.A. The dependence of the deflection of the arched truss loaded on the upper belt, on the number of panels // *Научный альманах*.

Kirsanov M.N. The deflection of spatial coatings with periodic structure. *Magazine of Civil Engineering*. 2017. No. 8. Pp. 58–66. doi: 10.18720/MCE.76.6

- number of panels. *Science Almanac*. 2017. No. 2-3(28). Pp. 268–271.
24. Rybakov L.S. Lineynaya teoriya ploskoj ortogonal'noj reshetki [Linear theory of a flat orthogonal grid]. *Mekhanika tverdogo tela*. 1999. No. 4. Pp. 174–189. (rus)
25. Marutyayn A.S., Pavlenko Yu.I. Priblizhennyi raschet perekrestnykh sistem na staticheskiye vozdeystviya [An approximate calculation of the cross-systems on static exposure]. *Stroitel'naya mekhanika i raschet sooruzheniy*. 2009. No. 4. Pp. 14–20.
26. Marutyayn A.S. *Legkiye metallokonstruktsii iz perekrestnykh sistem* [Light metal construction of cross systems]. Pyatigorskii gosudarstvennyy tekhnologicheskii universitet. – Pyatigorsk: Izd-vo RIA KMV, 2009. 348 p.
27. Marutyayn A.S., Grigoryan M.B., Glukhov S.A. Prostranstvennyye reshetchatyye nesushchiye konstruktsii (moduli tipa «Pyatigorsk»-2) [Spatial lattice supporting structures (modules of type "Pyatigorsk"-2)]. *Stroitel'naya mekhanika i raschet sooruzheniy*. 2014. No. 1. Pp. 64–71.
28. Galishnikova V.V., Dunaiski P., Pahl P.J. *Geometrically Nonlinear Analysis of Plane Trusses and Frames SUN MeDIA*, Stellenbosch (Republic of South Africa), 2009. 382 p.
2017. No. 2-3(28). С. 268–271.
24. Рыбаков Л.С. Линейная теория плоского призматического каркаса // Известия РАН. Механика твердого тела. 2001. № 106-118. (rus)
25. Марутян А.С., Павленко Ю.И. Приближенный расчет перекрестных систем на статические воздействия // Строительная механика и расчет сооружений. 2009. № 4. С. 14–20.
26. Марутян А.С. Легкие металлоконструкции из перекрестных систем. Пятигорск: Изд-во РИА КМВ, 2009. 348 с.
27. Марутян А. С., Григорьян М. Б., Глухов С. А. Пространственные решетчатые несущие конструкции (модули типа «Пятигорск»-2) // Строительная механика и расчет сооружений. 2014. № 1. С. 64–71.
28. Galishnikova V.V., Dunaiski P., Pahl P.J. *Geometrically Nonlinear Analysis of Plane Trusses and Frames SUN MeDIA*, Stellenbosch (Republic of South Africa), 2009. 382 p.

Mikhail Kirsanov,
+7(495)362-73-14; mpei2004@yandex.ru

Михаил Николаевич Кирсанов,
+7(495)362-73-14;
эл. почта: mpei2004@yandex.ru

© Kirsanov M.N., 2017