

THE MINISTRY OF EDUCATION AND SCIENCE OF THE RUSSIAN FEDERATION

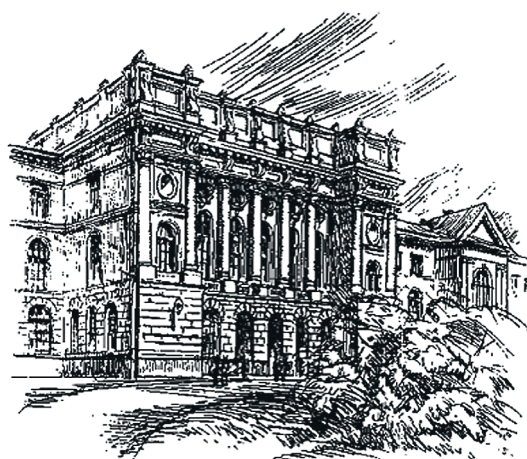

ST. PETERSBURG STATE
POLYTECHNICAL UNIVERSITY
JOURNAL

Economics

Vol. 10, No. 2, 2017

Polytechnical University Publishing House
Saint Petersburg
2017

ST. PETERSBURG STATE POLYTECHNICAL UNIVERSITY JOURNAL

EDITORIAL COUNCIL

I.I. Eliseeva – corresponding member of the Russian Academy of Sciences;
G.B. Kleiner – corresponding member of the Russian Academy of Sciences;
I.A. Maximtsev – Dr.Sc. (econ.), prof.;
V.V. Glukhov – Dr.Sc. (econ.), prof.

INTERNATIONAL EDITORIAL COUNCIL

Hanon Barabaner – Dr.Sc. (econ.), prof. (Estonia);
Jürg Becker – Dr.Sc., prof. (Germany);
Roy Damary – INSAM, Geneva (Switzerland);
Frederic Dimanche – SKEMA Business School, Nice (France);
Jürgen Jerger – Dr.Sc., prof. University of Regensburg (Germany);
Marja Kankaanranta – Adjunct prof. University of Oulu (Finland);
V.L. Kvint – foreign member of the Russian Academy of Sciences (USA);
Tomic Radovan – Dr.Sc., prof. Novi Sad Business School (Serbia);
Stefan Trzcielinski – Dr.Sc. (econ.), prof. (Poland);
Marco van Gelderen – PhD, VU University Amsterdam (Netherlands);
P.H. Azimov – Assoc. Prof. Dr., PhD (Tajikistan);
E.A. Kolos – Dr.Sc. (econ.), prof. (Kazakhstan);
L.N. Nehorosheva – Dr.Sc. (econ.), prof. (Byelorussia).

EDITORIAL BOARD

V.V. Gluhov – Dr.Sc. (econ.), prof., head of the editorial board;
A.V. Babkin – Dr.Sc. (econ.), prof., deputy head of the editorial board;
V.G. Basareva – Dr.Sc. (econ.), prof.;
E.M. Buhval'd – Dr.Sc. (econ.), prof.;
Ju.V. Vertakova – Dr.Sc. (econ.), prof.;
N.E. Egorov – Assoc. Prof. Dr.;
V.V. Kobzev – Dr.Sc. (econ.), prof.;
A.V. Kozlov – Dr.Sc. (econ.), prof.;
E.A. Malyshev – Dr.Sc. (econ.), prof.;
G.S. Merzlikina – Dr.Sc. (econ.), prof.;
A.A. Pahomova – Assoc. Prof. Dr.;
V.V. Pshenichnikov – Assoc. Prof. Dr.;
A.R. Safiullin – Dr.Sc. (econ.), prof.;
T.A. Salimova – Dr.Sc. (econ.), prof.;
A.N. Tsatsulin – Dr.Sc. (econ.), prof.;
S.V. Chuprov – Dr.Sc. (econ.), prof.;
A.N. Shichkov – Dr.Sc. (econ.), prof.

The journal is published under scientific and methodical guidance of the Russian Academy of Sciences since 1995.

The journal is included in the List of Leading Peer-Reviewed Scientific Journals and other editions to publish major findings of PhD theses for the research degrees of Doctor of Sciences and Candidate of Sciences.

The publications are presented in the VINITI RAS Abstract Journal and Ulrich's Periodical Directory International Database.

The journal was published since 2008 as part of the periodical edition *Nauchno-tekhnicheskie vedomosti SPbGPU* (ISSN 1994-2354)

Subscription index **36637** in the "Press of Russia" Joint Catalogue.

The journal is registered with the Federal Service for Supervision in the Sphere of Telecom, Information Technologies and Mass Communications (ROSKOMNADZOR). Certificate ПИ № ФС77-52146 issued December 11, 2012

The journal is on the Russian Science Citation Index (RSCI) data base

© Scientific Electronic Library (<http://elibrary.ru/>).

No part of this publication may be reproduced without clear reference to the source.

The views of the authors can contradict the views of the Editorial Board.

© Peter the Great Saint-Petersburg Polytechnic University, 2017

МИНИСТЕРСТВО ОБРАЗОВАНИЯ И НАУКИ РОССИЙСКОЙ ФЕДЕРАЦИИ

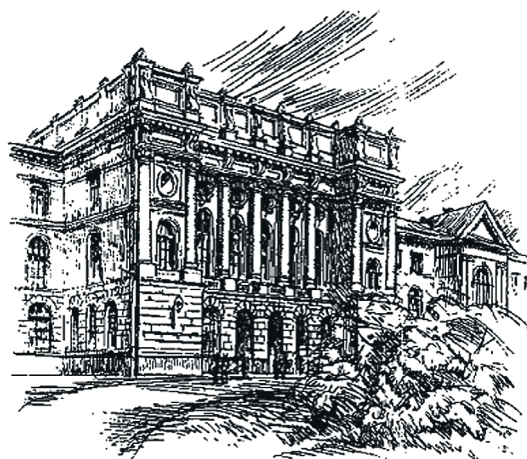

НАУЧНО-ТЕХНИЧЕСКИЕ ВЕДОМОСТИ

САНКТ-ПЕТЕРБУРГСКОГО ГОСУДАРСТВЕННОГО
ПОЛИТЕХНИЧЕСКОГО УНИВЕРСИТЕТА

Экономические
науки

Том 10, № 2, 2017

Издательство Политехнического университета
Санкт-Петербург
2017

НАУЧНО-ТЕХНИЧЕСКИЕ ВЕДОМОСТИ САНКТ-ПЕТЕРБУРГСКОГО ГОСУДАРСТВЕННОГО ПОЛИТЕХНИЧЕСКОГО УНИВЕРСИТЕТА

РЕДАКЦИОННЫЙ СОВЕТ

Елисеева И.И. (Санкт-Петербург), чл.-корр. РАН, д-р экон. наук, профессор; *Клейнер Г.Б.*, заместитель директора по научной работе Центрального экономико-математического института РАН, чл.-корр. РАН, д-р экон. наук, профессор; *Максимцев И.А.*, ректор Санкт-Петербургского гос. экономического университета, д-р экон. наук, профессор; *Глухов В.В.*, первый проректор Санкт-Петербургского политехнического университета Петра Великого, д-р экон. наук, профессор.

МЕЖДУНАРОДНЫЙ РЕДАКЦИОННЫЙ СОВЕТ

Барабанер Ханон, проректор Эстонского университета прикладных наук по предпринимательству, д-р экон. наук, профессор (г. Таллинн, Эстония); *Беккер Йорг*, проректор по стратегическому планированию и контролю качества Вестфальского университета им. Вильгельма, профессор (г. Мюнстер, Германия); *Дамари Рой*, Insam (Швейцария); *Димани Фредерик*, Высшая бизнес-школа (г. Ницца, Франция); *Ергер Юргин*, Университет Регенсбурга, д-р наук, профессор (Германия); *Канкаанранта Мария*, Университет Оулу (Финляндия); *Квинт В.Л.*, иностр. член РАН, д-р экон. наук, профессор (США); *Томич Радован*, Высшая деловая школа (г. Нови Сад, Сербия); *Тицелинский Стефан*, проректор по непрерывному образованию Технологического университета (г. Познань, Польша); *Марко Ван Гелдерен*, VU Университет Амстердама (Нидерланды); *Азимов П.Х.*, начальник международного управления Таджикского гос. технического университета им. акад. М.С. Осими, канд. экон. наук, доцент; *Колос Е.А.*, профессор кафедры, Восточно-Казахстанский гос. технический университет им. Д. Серикбаева, д-р экон. наук, профессор; *Нехорошева Л.Н.*, Белорусский гос. экономический университет, д-р экон. наук, профессор.

РЕДАКЦИОННАЯ КОЛЛЕГИЯ

Главный редактор – *Глухов В.В.*, первый проректор Санкт-Петербургского политехнического университета Петра Великого, д-р экон. наук, профессор.

Заместитель главного редактора – *Бабкин А.В.*, главный научный редактор, Санкт-Петербургский политехнический университет Петра Великого, д-р экон. наук, профессор.

Басарева В.Г., ст. науч. сотрудник Института экономики и организации промышленного производства СО РАН, д-р экон. наук, профессор (г. Новосибирск); *Бухвальд Е.М.*, заведующий центром Института экономики РАН, д-р экон. наук, профессор (г. Москва); *Вертакова Ю.В.*, заведующий кафедрой Юго-Западного гос. университета, д-р экон. наук, профессор (г. Курск); *Егоров Н.Е.*, гл. науч. сотрудник НИИ региональной экономики Севера Северо-Восточного федерального университета, канд. физ.-мат. наук, доцент (г. Якутск); *Кобзев В.В.*, заведующий кафедрой, Санкт-Петербургский политехнический университет Петра Великого, д-р экон. наук, профессор; *Козлов А.В.*, заведующий кафедрой, Санкт-Петербургский политехнический университет Петра Великого, д-р экон. наук, профессор; *Мальшев Е.А.*, заведующий кафедрой, Забайкальский гос. университет (г. Чита), д-р экон. наук, профессор; *Мерзликина Г.С.*, заведующий кафедрой, Волгоградский гос. технический университет (г. Волгоград), д-р экон. наук, профессор; *Пахомова А.А.*, профессор, Южно-Российский гос. политехнический университет (НПИ) им. М.И. Платова (г. Новочеркасск), д-р экон. наук, доцент; *Пишеничников В.В.*, Воронежский гос. аграрный университет им. Императора Петра I (г. Воронеж), канд. экон. наук, доцент; *Салимова Т.А.*, декан факультета, Мордовский гос. университет, д-р экон. наук, профессор (г. Саранск); *Сафуллин А.Р.*, заведующий кафедрой, Казанский (Приволжский) федеральный университет (г. Казань), д-р экон. наук, профессор; *Цацулин А.Н.*, профессор кафедры, Северо-Западный институт управления Российской академии народного хозяйства и гос. службы при Президенте РФ, д-р экон. наук, профессор; *Чупров С.В.*, проректор по научной работе Байкальского гос. университета, д-р экон. наук, профессор (г. Иркутск); *Шичков А.Н.*, заведующий кафедрой, Вологодский гос. университет, д-р экон. наук, профессор.

Журнал с 1995 года издается под научно-методическим руководством Российской академии наук

Журнал с 2002 года входит в Перечень ведущих рецензируемых научных журналов и изданий, где публикуются основные результаты диссертаций на соискание ученой степени доктора и кандидата наук.

Сведения о публикациях представлены в Реферативном журнале ВИНТИ РАН, в международной справочной системе «Ulrich's Periodical Directory».

С 2008 года выпускался в составе сериального периодического издания «Научно-технические ведомости СПбГПУ». ISSN 1994-2354.

Подписной индекс **36637** в объединенном каталоге «Пресса России».

Журнал зарегистрирован Федеральной службой по надзору в сфере информационных технологий и массовых коммуникаций (Роскомнадзор). Свидетельство о регистрации ПИ № ФС77-52146 от 11 декабря 2012 г.

Журнал включен в базу данных «Российский индекс научного цитирования» (РИНЦ), размещенную на платформе Научной электронной библиотеки на сайте <http://www.elibrary.ru>

При распечатке материалов ссылка на журнал обязательна.

Точка зрения редакции может не совпадать с мнением авторов статей.

© Санкт-Петербургский политехнический университет Петра Великого, 2017

Contents

Theoretical bases of economics and management

Boehlke J., Faldzinski M., Galecki M., Osinska M. Dynamics of economic growth in Ireland in 1980–2014.....	7
Aleksandrova A.I., Ostapovets E.A., Klochkova A.V. Directions of improving the public procurement system in the Russian Federation.....	21

Innovations management

Balashova E.S., Gnezdilova O.I. Innovations in russian industry: government support, expectations and reality.....	33
Mil'skaya E.A., Bychkova A.V. Analysis and evaluation of innovation and investment activities potential of economic entities (for example, the Northwestern Federal District)	44

Economy and management of the enterprise

Shichkov A.N. Operations management: converting manufacturing capital in manufacturing-technological systems of engineering business	54
Grishunin S.V. Developing the mechanism of qualitative risk assessment in strategic controlling	64

Economic-mathematical methods and models

Lipuntsov Y.P. Information and analytical components in modern applications	75
Strelnikova L.A., Lembrikova M.M. Using economic and mathematical models and methods to assess the human capital of a company in the field of IT industry	88
Tsatsulin A.N. The hybrid model of multivariate index analysis of current assets.....	98

Содержание

Теоретические основы экономики и управления

Бёльке Е., Фалдзинский М., Галецкий М., Осинска М. Динамика экономического роста в Ирландии в 1980–2014 гг.	7
Александрова А.И., Остаповец Е.А., Клочкова А.В. Направления совершенствования системы государственных закупок в Российской Федерации.....	21

Управление инновациями

Балашова Е.С., Гнездилова О.И. Инновации в российской промышленности: государственная поддержка, ожидания и реальность.....	33
Мильская Е.А., Бычкова А.В. Анализ и оценка потенциала инновационно-инвестиционной деятельности экономических субъектов (на примере Северо-Западного федерального округа).....	44

Экономика и менеджмент предприятия

Шичков А.Н. Операционный менеджмент: конверсия производственного капитала в производственно-технологических системах инженерного бизнеса.....	54
Гришунин С.В. Разработка механизма качественной оценки рисков в стратегическом контроллинге.....	64

Экономико-математические методы и модели

Липунцов Ю.П. Информационная и аналитическая компонента в современных приложениях.....	75
Стрельникова Л.А., Лембрикова М.М. Применение экономико-математических моделей и методов для оценки человеческого капитала сотрудников компании в сфере IT-индустрии.....	88
Цацулин А.Н. Гибридная модель многофакторного индексного анализа оборотных активов.....	98

DOI: 10.18721/JE.10201
UDC 3.33.338

DYNAMICS OF ECONOMIC GROWTH IN IRELAND IN 1980–2014

J. Boehlke, M. Faldzinski, M. Galecki, M. Osinska

Nicolaus Copernicus University, Torun, Poland

This paper is aimed at modelling a GDP growth rate in Ireland in order to separate the periods of particularly intense growth which are particularly important from the perspective of economic miracle definition. We applied a threshold error correction approach to cover several perspectives of the growth dynamics using different thresholds. A threshold cointegration approach allows to identify a long-run equilibrium within the context of different regimes, which provides a way of identification of asymmetric adjustment in both: short and long horizons. We extended the procedure of threshold identification by using individual economic variables as threshold variables and we further used a model with statistically significant parameters as a basis of testing. Enders and Siklos (2001) introduced the methodology to measure the long-run equilibrium in different ways, i.e., as SETAR and Momentum TAR. In general, GDP growth rate observed in 1980–2014 is the subject of analysis but we validate the results using a longer sample starting from 1973. We find that structural changes are most often identified in the period of recession of 2008–2009. Best models are obtained with the following thresholds: net income from the EU and GDP growth rate. This stresses the important role of investment and the source of its funds.

Keywords: intense economic growth; Ireland; threshold cointegration; validation

Citation: J. Boehlke, M. Faldzinski, M. Galecki, M. Osinska, Dynamics of economic growth in Ireland in 1980–2014, St. Petersburg State Polytechnical University Journal. Economics, 10 (2) (2017) 7–20. DOI: 10.18721/JE.10201

ДИНАМИКА ЭКОНОМИЧЕСКОГО РОСТА В ИРЛАНДИИ В 1980–2014 гг.

Е. Бёльке, М. Фалдзинский, М. Галецкий, М. Осинска

Университет Николая Коперника, Торунь, Польша

Статья посвящена моделированию темпов роста ВВП в Ирландии, чтобы отделить периоды особенно интенсивного роста, которые особенно важны с точки зрения определения экономического чуда. Мы применили пороговый подход коррекции ошибок, чтобы охватить несколько аспектов динамики роста с использованием различных пороговых значений, расширили процедуру идентификации порогового значения, используя отдельные экономические переменные в качестве порогового значения переменных и далее мы использовали модель со статистически значимыми параметрами как основу тестирования. Темпы роста ВВП, наблюдаемого в 1980–2014 гг., являются предметом нашего анализа. Мы представляем результаты за более длинный период, начиная с 1973 г., и считаем, что структурные изменения чаще всего фигурируют в период кризиса 2008–2009 гг. Лучшие модели получаются с помощью следующих

пороговых значений: чистый доход от темпов роста ВВП и ЕС. Это подчеркивает важную роль инвестиций и их источника.

Ключевые слова: интенсивный экономический рост; Ирландия; коинтеграционный порог; проверка

Ссылка при цитировании: Бёльке Е., Фалдзинский М., Галецкий М., Осинска М. Динамика экономического роста в Ирландии в 1980–2014 // Научно-технические ведомости СПбГПУ. Экономические науки. 2017. Т. 10. № 2. С. 7–20. DOI: 10.18721/JE.10201

Introduction. The issue of economic miracles has attracted the attention of many journalists, politicians, and economists for many years. A review of the literature in this field indicates considerable interest in this issue in the processes of modern economic growth covering the period following the Second World War from many researchers who are often very well-known in the area of social sciences and history. A postulate to attempt to develop a theory of economic miracles has even appeared in recent years (Selinger, 2010). Most often, the starting point for research in this area is the historically identified examples of economic miracles in some countries. Ireland is one of them. The focus of the research is set on economic, social and institutional causes and conditions of the economic growth path in Ireland. The case of Ireland has been widely studied in the economic literature (see for example Barry et al., 2001; Barry, 2002; Kelly and Everett, 2004 and also: Przesławska, 2009; Szczepaniak, 2015). Generally, all the authors agree that institutional development is the main source of economic and social success of Ireland although different sources of the success have been stressed.

The purpose of this article is to study a case of the economic miracle in Ireland measured by GDP growth rate using a threshold cointegration approach, which allows to identify a long-run equilibrium within the context of different regimes. This provides a way of identification of asymmetric adjustment in both short and long horizons. As it comes from the methodology introduced by Enders and Siklos (2001) the long run equilibrium phenomenon can be measured in different ways, i.e., as SETAR and *Momentum* TAR. Other ways of formulating threshold are also possible (see: Kapetanios et al., 2006; Bruzda, 2007). We extended the procedure of threshold identification by using individual economic variables as threshold variables and we further used a model with statistically significant parameters as a basis of testing. The data coming from the years 1980–2014 have been used for analysis. We validate our results by using a

longer time series from the years 1973–2014, which were available for selected variables only.

The article is organized as follows. In the second part, a brief description of Irish economy has been made. The econometric models used for empirical analysis of economic growth in Ireland were specified in section three, while empirical results are presented and discussed in section four. In section five, validation of the results has been performed. The conclusions and discussion are presented in the last part.

The economy of Ireland as an example of economic miracle. The economy of Ireland as an example of economic miracle has been a subject of a wide economic and statistical analysis in the last several years. The most recent book by O’Leary (2015) developed a multi-aspect discussion on such factors as technology, exports, as well as the taxation system and the policy of the government as very important determinants of growth of the country called ‘Celtic Tiger’. Bradley and Hannan (2001) analyzed, among others, the role of structural funds in Ireland’s recent economic growth and concluded that neither the Single Market nor the Structural Funds are likely to account fully for this increase in Ireland’s share. Yet another factor of success is related with the social partnership agreements. Furthermore, Bradley and Birnie (2001) analyzed whether a common united economy on the island of Ireland is possible using synergy coming from the great reforms that were introduced in both Northern Ireland and Ireland. Concerning the growth factors as the source of the economic success of the Irish economy, some economists emphasized the role of the Irish economic policy, especially stabilization policy and institutional reforms since the middle of last decade of the 20th century (changes in economic law, tax system, education) (Honohan, Walsh, 2002), others focused on the influence of FDI and financial support from EU funds (Barry, 2002) or explaining the Irish case as effective industrialization in the 1990s (Piński, 2013) and combination of economic policy, institutional reforms (especially regulatory reforms)

and membership in the EU (Szczepaniak, 2015). According to Cassidy, there are five important considerations in the discussion about the Irish economy: solid macroeconomic fundamentals, general regulatory environment supporting and encouraging business and entrepreneurship development, good access to risk capital, educational attainment of the workforce and conditions to R&D activity (Cassidy, 2004).

The arguments presented above provide a rationale for the analysis of Irish economy growth from the perspective of economic miracles. Interesting discussion on understanding the notion of the economic miracle and the characteristics, conditions, and consequences of this phenomenon is provided in a book edited by Balcerowicz and Rzońca (2014). Economic miracles are here a consequence of internal economic shocks caused by the national economic policy, at the root of which lie institutional determinants of changes in the economic system that could be barriers to, or drivers of development. The authors distinguish between two types of growth mechanisms, the first of which, based on innovations, is potentially sustainable and universal, whereas the «second type comprises specific growth mechanisms contained only in some situations formed by certain types of institutional systems, and/or deforming the economic policy, and they may be activated by respective reforms and, after some, sometimes a long time, they die out» (Balcerowicz, Rzońca, 2014). According to Balcerowicz and Rzońca, sustained acceleration of economic growth is a result of the successful introduction of a package of reforms, which must have an appropriate direction (liberal), temporal scope and structure, and be irreversible. Furthermore, the implemented reform packages should be the most productive in terms of the rate of economic growth. It is extremely difficult to answer the question of what factors could lead to raising the growth rate to very high levels. This is still one of the most important questions of the theory of development. Thus, at the current state of knowledge, the identification of periods of economic growth as a miracle always occurs *ex post*. According to Balcerowicz and Rzońca, historical experience suggests that in this case a reform package must significantly and permanently increase the pace of technology transfer from abroad, which requires a radical opening of the economy to the rest of the world,

deregulation, fiscal reforms raising the rate of savings and investment, and strengthening the protection of private property rights, etc.

An argument in favour of Balcerowicz and Rzońca's methodological proposals with regard to the research into economic development, in particular the phenomenon of miracles, could also be the studies by Acemoglu and Robinson (Acemoglu, Robinson, 2013). Similarly to Balcerowicz and Rzońca, they recognize the decisive effect of the institutional structure of the economy on its level of development, and growth rate. The so-called *inclusive* institutions, which guarantee freedom to the largest possible number of individuals, and provide strong incentives for cost- and socially effective actions, are conducive to rapid growth, whereas barriers to it are the consequence of the dominance of the so-called *extractive* institutions restricting the freedom of the individual and broad access to resources.

We found that this concept applies well to the case of Ireland, a country which succeeded in exciting the growth as well as placing itself among the best economies in the world. The facts are convincing. The dynamics of GDP in the years 1980–2014 is presented in Fig. 1. Average GDP annual growth rate of 1980–2008 was at 6.6 %. Ireland achieved the highest GDP level, i.e., 274.71 billion USD, in 2008. In the same period, GDP per capita (PPP) started from the level 13,434 USD in 1980, reached 37,276 USD in 2008 and finally 46,633 USD in 2014. According to the World Bank Group, the value of GDP in Ireland in 2014, amounting to 250.81 billion USD, represented 0.40 percent of the world economy. Ireland could be characterized as a rapidly growing economy before the last financial crisis and incredible GDP decrease after 2008. In the period of 2008–2010, average GDP growth rate was at minus 3.5 %. After negotiations with the European Union, the IMF and the World Bank Ireland has implemented a program of economic reforms. Since 2010, the Irish economy started to grow again. It is obvious that economic development of this country was supported by financial transfers from the European Union but the most important role was played by the Irish government's economic policy. In 2008 Ireland had the highest level of household debt relative to disposable income at about 190 %. Today, after the last financial crisis Ireland is the only PIIGS country growing very fast (over 7 % in 2015) with low government debt (about 1.5 % in 2015).

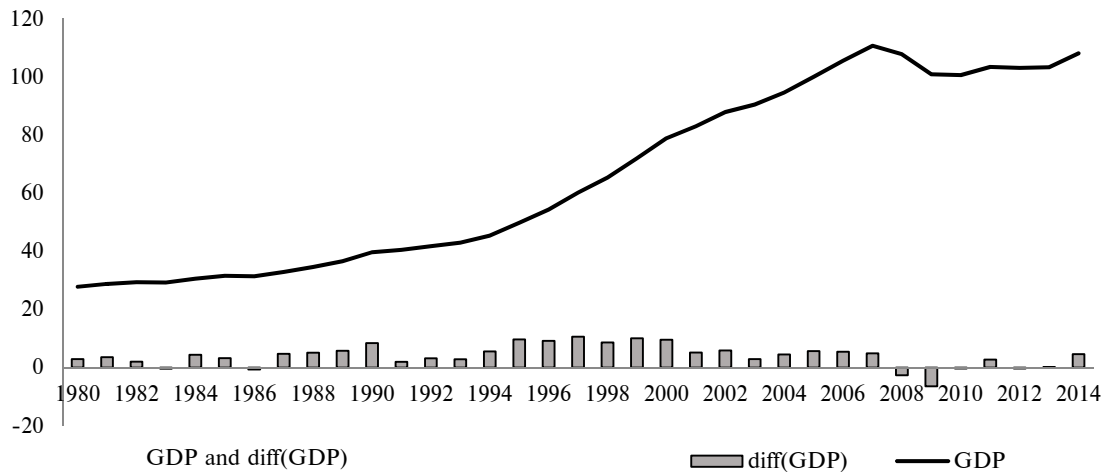

Fig. 1. GDP level and its dynamics in 1980–2014.

Source: Based on the data from Eurostat, <http://ec.europa.eu/eurostat>

Investigating the process of Irish economic development of 1980–2014, it could be observed that traditional factors lying behind relatively strong growth remained important. These include the economically efficient utilization of labor and capital in order to keep the economy operating at a level close to its economic potential. The economic growth of the Irish economy of 1980–2014 was mainly influenced by changes in multi-factor productivity, with spectacular growth observed in 1987–2000. They were determined by changes in both production factor resources and in their productivity. Unemployment rate in Ireland averaged 10.92 percent from 1983 until 2016, reaching an all-time high of 17.30 percent in December of 1985 and a record low of 3.70 percent in December of 2000. In 2016 it was established at the level of 7.8 percent. It is obvious that aggregate productivity growth depends on the productivity of firms operating in Irish economy but from the perspective of economic policy the most important issue is to ensure institutional structures and policy settings supporting investment processes, innovations, good managerial practices, efficient working incentives, entrepreneurship and risk taking.

The brake-point in Irish economic history was the accession to EEC in 1973. The most spectacular achievements were noticed in a period from 1980 to 2007. Since 1987, a voluntary «pay pact» between the government, Trade Unions and employers was a very important institution to reduce public debt and wages. Because of them the Irish economy was described as the «Celtic Tiger». In economic literature many researchers have emphasized the importance of a political

consensus in the 1980s as a basic element of Irish socio-political changes. It influenced the shape and the implementation mode of economic recovery strategy, especially from the fiscal and monetary policy point of view. Strategic issues for long-term economic growth exposed changes in the structure of Irish economy by investment in infrastructure, especially in public transport, new housing, IT sector and protection of the nature environment (O’ Hagan and Newman, 2005). The very important reason of Irish economic success was also a relatively high level of human capital value as a result of centrality of investment in education sector. It had important implications for macroeconomic and regional strategy and policy. In the case of the English-speaking society, it is no accident that almost 50 % of foreign direct investments from United States and Great Britain had been allocated in that very internationally oriented country, especially in the information technology sector and financial and legal services. The case of Ireland shows an importance of opening up to the global economy but from another perspective the fact remains that cultural diversity within the country was also a great advantage in its socio-economic success.

The threshold error-correction class of models. After the Washington consensus being introduced, the economists have gone from the issue of real growth factors and replaced it with the institutional framework that is necessary for growth being operated. However, Durlauf (2000) showed his concern about the possibility of effectively modelling the legal, social or political factors in the

context of economic growth because most of them are endogenously related with the level of growth. Durlauf et al. (2005) continued arguing that modelling the economic growth based on time series is limited due to short series of data (available only after 1960), sensitivity of growth to business cycles and other short-run instabilities. However nonlinearity and multi-regimes in the growth patterns was from their viewpoint very important. On the other hand, after the last recession of the first decade of the 21st century it became clear that creating economic growth is still of great importance. Having in mind all these concerns, remarks and needs we tried to model economic growth in Ireland using a simple but nonlinear approach, i.e., a threshold approach (see Tong, 1990). We based our interest on the fact that before 1980s Ireland was really a poor country and the growth factors must have been introduced exogenously, possibly using a discrete threshold. This assumption determined the set of threshold variables analysed in the research. At the very beginning we assumed a long-run dynamics, that means a long-run equilibrium path and short-term adjustment. We based our research on TAR and M-TAR approaches defined by Balke and Fomby (1997), and, by Enders and Siklos (2001). A starting point of the Enders and Siklos procedure is the following long-run equation (1):

$$Y_t = \alpha_0 + \sum_{i=1}^k \alpha_i X_{it} + u_t, \quad (1)$$

where all variables Y_t, X_{it} for $i = 1, \dots, k$ are assumed to be I(1). Stationarity of the adjustment process (residual process) satisfies a threshold cointegration if:

$$\Delta u_t = I_t \rho_1 u_{t-1} + (1 - I_t) \rho_2 u_{t-1} + \sum_{i=1}^p \beta_i \Delta u_{t-i} + \varepsilon_t, \quad (2)$$

where

$$I_t = \begin{cases} 1 & \text{for } u_{t-1} \geq \gamma, \\ 0 & \text{for } u_{t-1} < \gamma \end{cases} \quad (3)$$

in the case of TAR-type adjustment or

$$I_t = \begin{cases} 1 & \text{for } \Delta u_{t-1} \geq \gamma, \\ 0 & \text{for } \Delta u_{t-1} < \gamma \end{cases} \quad (4)$$

in the case of M-TAR-type adjustment.

The procedure provided by Engle and Siklos (2–4) was the subject of modifications. In 2006 Kapetanios, Shin and Snall proposed other types of indication function than (3–4) and assumed maximum one co-integration vector. In 2007 Bruzda implemented equation (5) to test the threshold co-integration, taking into account that in the case of common factors model (5) can be reduced to the form given by (2). Otherwise, a test equation in the form (5) improves the power of the procedure. The hypothesis of lack of threshold cointegration is as follows: $H_1: \rho_1 = \rho_2 = 0$ and implies a linear cointegration. The threshold error correction model (TECM hereafter) takes the form:

$$\Delta Y_t = I_t \rho_1 u_{t-1} + (1 - I_t) \rho_2 u_{t-1} + \omega \Delta X_t + \sum_{j=1}^p \psi_{yj} \Delta Z_{t-j} + e_t, \quad (5)$$

where: $Z_t = (Y_t, X_{1t}, X_{2t}, \dots, X_{kt})'$, $X_t = (X_{1t}, X_{2t}, \dots, X_{kt})'$, u_t is a residual process from eq. (1) and I_t is the Heaviside function (3) or (4) and γ is a threshold value.

The asymmetry of adjustment to long-run equilibrium is tested using the following hypothesis $H_2: \rho_1 - \rho_2 = 0$. If asymmetry is confirmed it means that the speed of adjustment to the long-run path differs between negative and positive sides. The mechanism of adjustment depends of the threshold variable that reveals which forces dominated over the indicated periods.

In the reported research model (5) has been used as a basis of testing, but threshold variables were taken individually from the following: the long-run regression of the form (1) and their first differences. In the next step a new testing equation of the form (6) has been proposed when regimes are split not only by lagged ECMs but also by the lagged values of exogenous and endogenous variables. The intuition for composing Eq. 6 lies in the fact that asymmetry in the adjustment process can occur in the short-run, and can result from the changes of the variables other than the ECM. A test similar to the procedure defined by Enders and Siklos is conducted using the statistically significant Eq. (6).

Then the proposed TECM model takes the following form:

$$\Delta Y_t = I_t \rho_1 u_{t-1} + (1 - I_t) \rho_2 u_{t-1} + I_t \omega_1 \Delta X_t + (1 - I_t) \omega_2 \Delta X_t + \sum_{j=1}^{\max\{p;q\}} I_t \psi_{1yj} \Delta Z_{t-j} + \sum_{j=1}^{\max\{p;q\}} (1 - I_t) \psi_{2yj} \Delta Z_{t-j} + e_t, \quad (6)$$

where: Z_t , X_t , u_t and γ are defined as in (5) and I_t for individual variables is constructed similarly to (3) and (4).

As mentioned above, Eq. (6) was not only the testing formula. Eq. (6) shows the possibility of a discrete threshold coming from: an adjustment to the long-run path (1), an exogenous threshold ΔX_{it-j} or an endogenous change ΔY_{t-s} . All elements exhibit different sources of the short-run regime changes and short-run asymmetry.

Empirical study. The empirical research was focused on modelling the GDP process in Ireland observed in 1980–2014, yearly observations. Its aim was to identify possible structural breaks and further to explain the causes for structural breaks with threshold models. The set of time series taken into account is summarized in Tab. 1. The data were taken in both: levels and logs. The original GDP series were filtered with the Hodrick-Prescott filter to remove cyclical pattern.

Table 1

Variables used in the study (constant prices)

variable	variable name	variable unit
GDP_t	Gross Domestic Product	billion of euro
FDI_t	Foreign Direct Investment	millions of euro
NI_EU_t	Net income from EU	millions of euro
EMP_t	Employment	Thousand
PD_t	Public Debt	billions of euro
$Deflator_t$	GDP deflator	[%] of GDP
I_t	Investments	billions of euro
N_Ex_t	Net Exports	billions of euro
SR_t	Short-term interest rate	[%]
LR_t	Long-term interest rate	[%]
MFP_t^*	Multi-factor productivity	[%] change
FDI_t/GDP_t		[%]
NI_EU_t/GDP_t		[%]
I_t/GDP_t		[%]
GNP_t	Gross National Product	billion of euro

The data were downloaded from <http://www.economywatch.com/economic-statistics/country/Ireland/>, <http://www.cso.ie/en/statistics/>, <http://stats.oecd.org/>

* MFP_t was observed only in 1980–2011.

At the first step we tested the time series for unit roots/stationarity using both: the Philips and Perron – PP (1988) and the KPSS (Kwiatkowski et al. 1992) tests. Then, the Andrews and Zivot (1992) endogenous structural break test has been applied. Based on the PP test, all the variables have one unit root, whereas four variables, i.e., $Deflator_t$, PD_t , EMP_t and GDP_t (with and without cyclical component) have two unit roots. KPSS test results show that all the variables have one unit root beside NI_EU_t . We have to keep in mind that time series are quite short ($n=35$ observations) and it could affect the conclusions. Thus in further steps we assumed that all variables were $I(1)$. Concerning the Andrews and Zivot test results, it can be said that only two variables do not have one unit root (PD_t and Sr_t) at a 5 % significance level. The break date has been identified around 2008 year, which predominates for levels and differences. This is due to the financial and economic crisis which interrupted the fast growth in Ireland. This fact stays in line with other general findings and implies nonlinearity, as, for example, in Woo and Kumar (2015). However, structural breaks in the 1990s were also supported by the data. The breaks located in 1980s and 1990s were shown in short interest rate and net income from the EU when original data were considered and net exports when logs were analysed¹.

At the second stage the procedure described in section 3 (Eqs. 1–8) has been applied. The results of the original Engle and Siklos test showed that in three cases out of four the Engle and Siklos test supports the hypothesis of threshold cointegration (see Tab. 2 for comparison). This means that around the long-run path, asymmetry of short-term adjustment can be observed. This finding provides a basis for further investigation in order to reveal the possible significant threshold variables that influence the economic growth pattern in Ireland.

The results of testing for threshold cointegration and asymmetry using the approach proposed in the paper are given in Tab. 3 and 4.

¹ The results of PP, KPSS and Andrews and Zivot test are available from the authors on request.

Table 2

Enders and Siklos test results based on Eq. 2

Threshold variable	Value of threshold	Long-term equation	Hypothesis	p-value	Remarks
ECM(t-1)_SETAR	0	Original data	H0: ($\rho_1 = \rho_2 = 0$)	0.0014	Cointegration
ECM(t-1)_SETAR	0	Original data	H2: ($\rho_1 - \rho_2 = 0$)	0.8651	No-asymmetry
Δ ECM(t-1)_M-TAR	0	Original data	H0: ($\rho_1 = \rho_2 = 0$)	0.0490	Threshold cointegration
Δ ECM(t-1)_M-TAR	0	Original data	H2: ($\rho_1 - \rho_2 = 0$)	0.1240	Asymmetry
ECM(t-1)_SETAR	0	Logarithmic data	H0: ($\rho_1 = \rho_2 = 0$)	<0.0001	Threshold cointegration
ECM(t-1)_SETAR	0	Logarithmic data	H2: ($\rho_1 - \rho_2 = 0$)	0.0391	Asymmetry
Δ ECM(t-1)_M-TAR	0	Logarithmic data	H0: ($\rho_1 = \rho_2 = 0$)	<0.0001	Threshold cointegration
Δ ECM(t-1)_M-TAR	0	Logarithmic data	H2: ($\rho_1 - \rho_2 = 0$)	0.1066	Asymmetry

Table 3

Enders and Siklos test results based on Eq. 6. Threshold variable: original data – levels and differences

Threshold variable	Threshold value	Long-term equation*	Hypothesis	p-value	Remarks
HP_GDP(t-5)	162.57	Yes	H0: ($\rho_1 = \rho_2 = 0$)		Too few observations in the regime
FDI(t-5)	18210.64	No	H0: ($\rho_1 = \rho_2 = 0$)		Too few observations in the regime
NI_EU(t-2)	1627.90	Yes	H0: ($\rho_1 = \rho_2 = 0$)	0.0135	Threshold cointegration
NI_EU(t-2)			H2: ($\rho_1 - \rho_2 = 0$)	0.0005	Asymmetry
EMP(t-4)	1901.60	Yes	H0: ($\rho_1 = \rho_2 = 0$)		Too few observations in the regime
PD(t-4)	46.68	Yes	H0: ($\rho_1 = \rho_2 = 0$)		Too few observations in the regime
Deflator(t-3)	64.90	No	H0: ($\rho_1 = \rho_2 = 0$)	0.0076	Threshold cointegration
Deflator(t-3)			H2: ($\rho_1 - \rho_2 = 0$)	0.1215	Asymmetry
I(t-3)	38.22	Yes	H0: ($\rho_1 = \rho_2 = 0$)		Too few observations in the regime
Lr(t-3)	7.28	No	H0: ($\rho_1 = \rho_2 = 0$)	0.4730	Lack of cointegration E-S
Lr(t-3)					TAR model
N_Ex(t-4)	39.05	Yes	H0: ($\rho_1 = \rho_2 = 0$)		Too few observations in the regime
Sr(t-5)	6.25	Yes	H0: ($\rho_1 = \rho_2 = 0$)	0.2897	Lack of cointegration
Sr(t-5)					TAR model
ECM(t-1)	0	Yes	H0: ($\rho_1 = \rho_2 = 0$)	0.0944	Partial cointegration
ECM(t-1)					Insignificant parameter pECM
Δ HP_GDP(t-4)	2.98	Yes	H0: ($\rho_1 = \rho_2 = 0$)	0.0003	Partial cointegration
Δ HP_GDP(t-4)					Insignificant parameter pECM
Δ FDI(t-5)	-6542.51	No	H0: ($\rho_1 = \rho_2 = 0$)		Too few observations in the regime
Δ NI_EU(t-5)	-11.50	Yes	H0: ($\rho_1 = \rho_2 = 0$)	<0.0001	Partial cointegration
Δ NI_EU(t-5)					Insignificant parameter pECM
Δ EMP(t-5)	15.40	Yes	H0: ($\rho_1 = \rho_2 = 0$)	<0.0001	Partial cointegration
Δ EMP(t-5)					Insignificant parameter pECM
Δ PD(t-3)	2.44	Yes	H0: ($\rho_1 = \rho_2 = 0$)	0.0293	Partial cointegration
Δ PD(t-3)					Insignificant parameter nECM
Δ Deflator(t-1)	1.7	No	H0: ($\rho_1 = \rho_2 = 0$)	0.1177	Partial cointegration
Δ Deflator(t-1)					Insignificant parameter nECM
Δ I(t-5)	-0.91	Yes	H0: ($\rho_1 = \rho_2 = 0$)		Too few observations in the regime
Δ Lr(t-5)	0.34	No	H0: ($\rho_1 = \rho_2 = 0$)		Too few observations in the regime
Δ N_Ex(t-5)	2.82	Yes	H0: ($\rho_1 = \rho_2 = 0$)		Too few observations in the regime
Δ Sr(t-4)	0.58	Yes	H0: ($\rho_1 = \rho_2 = 0$)		Too few observations in the regime
Δ MFP(t-1)	2.5	No	H0: ($\rho_1 = \rho_2 = 0$)	0.0500	Partial cointegration
Δ ECM(t-1)	0	Yes	H0: ($\rho_1 = \rho_2 = 0$)	0.0136	Partial cointegration
Δ ECM(t-1)			H2: ($\rho_1 - \rho_2 = 0$)		Positive sign nECM

* The term «long-term equation» in Tab. 6–7 denotes the presence of the threshold variable in the long-term equation.

Table 4

Enders and Siklos test results based on Eq. 6. Threshold variable: logarithmic data and differences of logarithms

Threshold variable	Threshold value	Long-term equation	Hypothesis	p-value	Remarks
HP_GDP(t-5)	4.33	Yes	H0: ($\rho_1 = \rho_2 = 0$)	0.1147	Threshold cointegration
HP_GDP(t-5)			H2: ($\rho_1 - \rho_2 = 0$)	0.1480	Asymmetry
FDI(t-5)	9.81	No	H0: ($\rho_1 = \rho_2 = 0$)		Too few observations in the regime
NI_EU(t-5)	6.16	No	H0: ($\rho_1 = \rho_2 = 0$)		Too few observations in the regime
I(t-5)	2.51	No	H0: ($\rho_1 = \rho_2 = 0$)		Too few observations in the regime
Sr(t-5)	6.25	No	H0: ($\rho_1 = \rho_2 = 0$)	0.0856	Partial cointegration
Sr(t-5)			H2: ($\rho_1 - \rho_2 = 0$)		Insignificant parameter nECM
N_Ex(t-5)	1.15	Yes	H0: ($\rho_1 = \rho_2 = 0$)		Too few observations in the regime
EMP(t-4)	0.64	Yes	H0: ($\rho_1 = \rho_2 = 0$)		Too few observations in the regime
PD(t-3)	3.84	Yes	H0: ($\rho_1 = \rho_2 = 0$)		Too few observations in the regime
Lr(t-3)	7.29	No	H0: ($\rho_1 = \rho_2 = 0$)	0.7999	Lack of cointegration
Lr(t-3)					TAR model
ECM(t-1)	0	Yes	H0: ($\rho_1 = \rho_2 = 0$)	0.0107	Cointegration
ECM(t-1)			H2: ($\rho_1 - \rho_2 = 0$)	0.6128	No-asymmetry
Δ HP_GDP(t-4)	0.022	Yes	H0: ($\rho_1 = \rho_2 = 0$)		Too few observations in the regime
Δ FDI(t-5)	-0.252	No	H0: ($\rho_1 = \rho_2 = 0$)		Too few observations in the regime
Δ NI_EU(t-4)	-0.273	No	H0: ($\rho_1 = \rho_2 = 0$)		Too few observations in the regime
Δ Lr(t-5)	0.340	No	H0: ($\rho_1 = \rho_2 = 0$)		Too few observations in the regime
Δ Sr(t-4)	0.580	No	H0: ($\rho_1 = \rho_2 = 0$)		Too few observations in the regime
Δ N_Ex(t-2)	0.054	Yes	H0: ($\rho_1 = \rho_2 = 0$)	0.0086	Partial cointegration
Δ N_Ex(t-2)					Insignificant parameter nECM
Δ I(t-4)	-0.017	No	H0: ($\rho_1 = \rho_2 = 0$)	0.6627	Lack of cointegration
Δ I(t-4)					TAR model
Δ PD(t-4)	0.051	Yes	H0: ($\rho_1 = \rho_2 = 0$)		Too few observations in the regime
Δ EMP(t-5)	0.005	Yes	H0: ($\rho_1 = \rho_2 = 0$)		Too few observations in the regime
Δ Deflator(t-1)	0.052	Yes	H0: ($\rho_1 = \rho_2 = 0$)		Too few observations in the regime
Δ MFP(t-1)	2.5	No	H0: ($\rho_1 = \rho_2 = 0$)	0.0093	Threshold cointegration
Δ ECM(t-1)	0	Yes	H0: ($\rho_1 = \rho_2 = 0$)	0.0104	Partial cointegration
Δ ECM(t-1)			H2: ($\rho_1 - \rho_2 = 0$)		Insignificant parameter nECM

The results presented in Tab. 3–4 show the problem that was indicated at the very beginning of the paper, i.e., low number of observations applicable for the research. The severe limitations resulting from that fact are indicated in tables by the comment «too few observations in the regime». However, we were able to find out that in cases when net income from the EU lagged by 2 years, the deflator lagged by 3 years (for original data) and HP_GDP lagged by 5 periods and multifactor productivity (MFP) lagged by 1 (for logs), significant threshold cointegration took place. These variables, apart from the GDP deflator and MFP, were present in the long-run relationship. Thus the case of deflator puts our attention on the prices level in

Ireland in 1980–2014. It is worth noting that for original data the threshold value of net income from the EU was equal to 1,627.9 (mln euro) and in the case of deflator the cumulated prices change was about 64.90 %. The value of the HP_GDP threshold for logs is equal 4.33.

In the third stage of the research the estimation of TECM parameters and testing for threshold cointegration and asymmetry of adjustment in the TECM model was carried out. The aim of this stage was to estimate (symmetric or asymmetric) reaction of the economy (measured in GDP) on the growth factors measured as threshold variables. The long-run models (ECM-terms) are shown in Tab. 5, while the best TECM models indicated by BIC are presented in Tab. 6 and 7.

Table 5

The long-run models for GDP

Variable	HP_GDP		HP_log_GDP	
	parameter estimate	p-value	parameter estimate	p-value
Const	-27.367	0.0010	-4.287	0.0000
NI_EU	0.005	0.0000		
EMP	0.066	0.0000	1.033	0.0000
N_Ex	0.848	0.0000	0.066	0.0000
Sr	-0.566	0.0096	-0.008	0.0520
I	0.367	0.0131		
PD	0.127	0.0000	0.070	0.0000
Deflator			0.228	0.0002
DW test		1.5313	DW test	1.0813
R ²		0.9988	R ²	0.9960
QLR test		0.0001	QLR test	0.0000

QLR test represents Quandt's test for structural breaks (Quandt, 1960).

Table 6

The best TECM models for non-logarithmic data

Dependent variable	Threshold variable		Value of threshold		Threshold variable		Value of threshold	
Δ HP_GDP	NI_EU(t-2)=		1.6		deflator(t-3)=		64.9	
	N1=	10	N2=	22	N1=	16	N2=	14
	AIC=		-61.40		AIC=		-60.14	
variable	I_regime	p-value	II_regime	p-value	I_regime	p-value	II_regime	p-value
const	4.5271	<0.0001	-0.8729	0.0186	-0.2375	0.1396	0.1155	0.1713
Δ Sr			-0.2440	0.0183	-0.1818	0.0002	-0.0514	0.0001
Δ Lr	-0.0407	0.0107					0.0952	0.0011
Δ I	0.3237	<0.0001	0.1302	0.0273			-0.0402	0.0162
Δ PD	0.0911	<0.0001	0.0731	0.0002	0.0148	0.0160	-0.0240	0.0023
Δ FDI	-0.0001	<0.0001	0.0000	0.0004			0.0001	0.0163
Δ NI_EU	0.0012	<0.0001	0.0022	0.0001	0.0005	0.0462	-0.0001	0.0772
Δ EMP	0.0494	<0.0001	0.0267	<0.0001	0.0079	<0.0001	0.0029	0.0999
Δ Deflator			0.2890	0.0008	0.2100	<0.0001	0.0813	0.0207
Δ N_Ex	-0.2670	<0.0001	0.3325	<0.0001	0.0888	0.0001		
Δ ECM(t-1)	-0.2458	<0.0001	-0.4437	0.0002	-0.1926	<0.0001	-0.0446	0.0073
Δ HP_GDP(t-1)			0.6109	<0.0001	0.7539	<0.0001	1.0815	<0.0001
ARCH LM(4)	4.298	(0.367)	3.278	(0.512)	3.047	(0.550)	3.967	(0.411)
Ljung-Box	Q(2)	2.58	(0.276)				1.08	(0.583)
	Q(3)				3.64	(0.303)		
	Q(4)			3.06	(0.547)			

In last four rows p-values are given in brackets. N1 and N2 mean the number of observations in the I and II regime respectively.

Table 7

The best TECM models for logarithmic data

Dependent variable	Threshold variable		Value of threshold		Threshold variable		Value of threshold	
Δ HP_GDP	HP_log_GDP(t-5)		4.335		MFP(t-1)		2.5	
	N1=	16	N2=	12	N1=	15	N2=	11
	AIC =		-371.99		AIC =		-267.53	
variable	I_ regime	p-value	II_ regime	p-value	I_ regime	p-value	II_ regime	p-value
const	-0.0011	0.1421	0.0031	0.0002	-0.0098	0.0018	0.0252	<0.0001
Δ Sr	-0.0018	<0.0001			-0.0016	<0.0001		
Δ Lr					-0.0030	<0.0001		
Δ I			-0.0162	<0.0001			0.2141	<0.0001
Δ FDI	-0.0002	0.0316	0.0029	<0.0001				
Δ NI_EU			-0.0088	<0.0001	0.0312	<0.0001	-0.0111	0.1627
Δ EMP	0.0366	0.0573	0.1075	<0.0001	0.2275	<0.0001		
Δ Deflator	0.1479	<0.0001	0.0820	<0.0001				
Δ N_Ex			-0.0058	<0.0001	0.0538	<0.0001	0.0503	0.0005
Δ ECM(t-1)	-0.0848	0.0021	-0.0308	<0.0001	-0.1898	<0.0001	-0.6201	0.0012
Δ HP_GDP(t-1)	0.7864	<0.0001	0.9846	<0.0001	0.8589	<0.0001		
ARCH LM(4)	4.499	(0.343)	2.546	(0.636)	4.788	(0.310)	1.373	(0.849)
Ljung-Box	Q(2)		3.32	(0.191)			2.13	(0.346)
	Q(3)	2.78	(0.427)			4.098	(0.251)	

In last two rows p-values are given in brackets. N1 and N2 mean the number of observations in the I and II regime respectively.

The results of both the long-term equations and TECM estimation show that reasonable estimates were obtained for the parameters. In general, parameter estimates in the long-run equations were greater in magnitude than the short-term adjustment coefficients for logarithmic and non-logarithmic data. The parameter estimates standing for the adjustment to the long-run path are different for negative and positive side of the long run equilibrium. They are presented in tables as Δ ECM(t-1) in the I regime and in the II regime. For net income from the EU playing a role of the threshold variable the adjustment form was faster in magnitude (-0.44) from the negative side than from the positive side (-0.24). In the case of deflator the magnitude was as follows: -0.19 from the positive side and -0.04 from the negative one. In the case of HP_log_GDP lagged by 5 periods, the magnitude was much lower: -0.08 and -0.03, respectively.

Fig. 2 shows the division of the growth period in Ireland according to NI_UE. In the case of net income from the EU that flowed to

Ireland in the observed period the following division can be observed: from 1981 to 1990, from 1991 to 2000 and from 2001 to 2014. These periods are quite reasonable taking into account the Irish economic policy in the past. Since putting the reforms into operation and getting more money from abroad (net income from the EU, FDI) in the 1980s, it took a decade to build the mechanism of growth. This type of growth was of exogenous nature, influencing by institutional changes as well as the money from external sources, which was supported by other research results discussed in section 3 of this article. In this period the adjustment to the long-run path from the negative side was dominating. In the decade of 1991-2002 the most spectacular economic growth took place, amounting to 8 % per year. In this time a greater economic force acted to push up the economy and to enable catching up processes. In the last twelve years of the analyzed period the growth was slowed down and then economic recession took place.

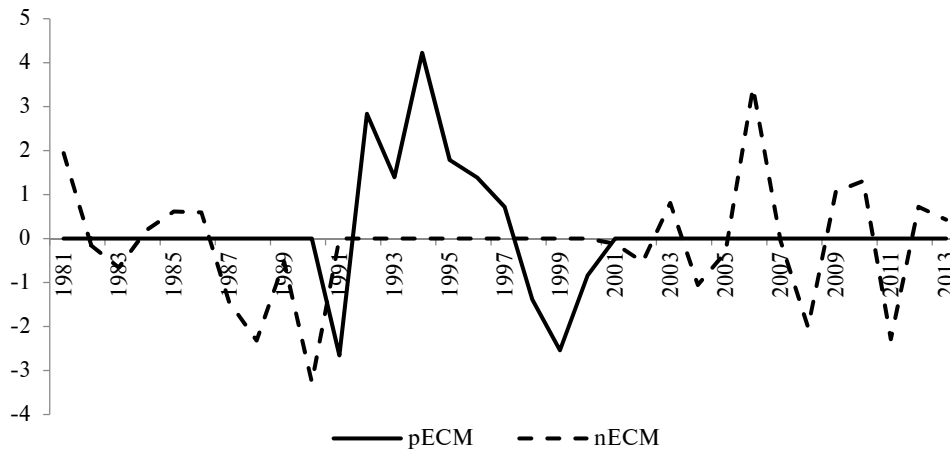

Fig. 2. ECM for the threshold variable: NI_EU(t-2)

It was a heavy time for the economy that suffered from recession very much. However, after 2010, the Irish economy has been recovering. Again the adjustments from negative side was of greater magnitude.

Validation of the estimated tecm models In this part of the paper we described briefly the validation procedure of the results obtained above. To do so, we prolonged a sample to have more observations for analysis. As the longer time series were not available for some variables, the following data were taken into account: HP_GDP_t, FDI_t, NI_EU_t, EMP_t, Deflator_t, N_Ex_t, SR_t, LR_t (notation as above). We had to omit two variables, i.e., investment and debt/GDP ratio. The longer period of the analysis covered the following years: 1973–2014. Thus the whole procedure was repeated for a longer time series. The results of the Enders and

Siklos procedure let us accept threshold cointegration only for the case of the logarithms. This result is affected by the two following reasons. The first one is obviously related with the longer sample but the second one is that the empirical ECM model has been changed according to available information.

We followed the procedure for all types of the models described in section 4. However, the most important question was which of the threshold variables (if any) that were described in section 4 remained the same in the longer period of the analysis. The results of testing are shown in Tab. 8.

Using the proposed procedure based on model (6), we found out that only the net income from the EU remained as the important threshold for the growth pattern in the economy of Ireland. Besides the error correction mechanism in differences is a significant threshold as well.

Table 8

The modified Enders and Siklos test – TECM model

Threshold variable – differences	Threshold value	Long run eq. – sect 4.	Threshold variable present in the long run eq.	H0: ($\rho_1 = \rho_2 = 0$) p-value	H2: ($\rho_1 = \rho_2 = 0$) p-value
Δ ECM(t-1)	0	1	Yes	0.0019	0.0000
Δ Deflator(t-1)	1.7	1	No	0.0000	0.8471
Δ NI_UE(t-5)	153.9	1	Yes	0.0000	0.0009
Threshold variable – differences	Decision		Remarks		
Δ ECM(t-1)	Threshold cointegration		Asymmetry		
Δ Deflator(t-1)	Cointegration		No-asymmetry		
Δ NI_UE (t-5)	Threshold cointegration		Asymmetry		

Conclusions. In the paper, the economic growth in Ireland was considered from the economic miracle point of view. Despite a small number of observations that was an important limitation for empirical research, we managed to indicate the most important thresholds and asymmetries in the GDP growth rate in Ireland in 1980–2014. The investigation has been repeated for GDP in the years 1973–2104. The time series in interest were nonstationary and exhibited structural change in different moments in time. The structural change was most often identified in the period of recession of 2008–2009 (12 cases, and 1991/92 – Δ HP_GDP). It is noteworthy that threshold cointegration was confirmed in all cases using the original Enders-Siklos test. Moreover, individual threshold variables (other than ECM) are related to: asymmetry of the short-run adjustment (1), possibility that the threshold variables are not present in the long-run equation (2). The following threshold variables were identified such as: net income from the EU (NI_EU), GDP deflator (deflator), lagged GDP (HP_GDP) and multifactor productivity (MFP). Best models are obtained with the following thresholds: net income from the EU and lagged HP_GDP which represents the endogenous growth factor. It shows the important role of investment in the growth creation process and the source of its funds. In the case of NI_EU: the adjustment from the negative side of the threshold is faster than from the positive side. In the case of deflator, an opposite direction was shown by the data. In the case of lagged HP_GDP, a faster short-run adjustment was from the positive side (above the threshold). It can be explained by the fact that an exogenous factor like net income from the EU accelerated the economic growth

when it was at a lower level. While endogenous forces (represented by the deflator and the GDP itself) were put into operation, the system was never overheated in comparison to the long-run equilibrium level. Threshold variables allowed to divide the periods of economic growth in Ireland showing the most important forces that accelerated the Irish economy in the 1990s. The asymmetry of short-run adjustment was due to net income from the European Union, the inflation represented by the deflator of GDP as well as by endogenous growth. Additionally, it should be mentioned that the obtained results can be helpful for policy decision-makers or European institutions in order to better understand the properties of economic growth.

It is worth mentioning that the validation of the model in the longer time period, i.e., 1973–2014 confirmed that net income from the European Union was the most important exogenous force driving the growth pattern in Ireland. Other variables considered in the long run (Δ ECM_{t-1}) were also of great importance.

The impact of net income from the EU was possible because of the preceding institutional reforms consisting in the dominance of inclusive institutions in national economy as well as the successive changes in the economic policy rules. Thus Ireland is a case of the economic miracle which can be perceived as a period of rapid economic growth in one of the highly developed (core) countries in the world's economic system.

Financial support of the National Science Centre in Poland (UMO-2015/17/B/HS4/01000) is gratefully acknowledged.

The authors are grateful to Cormac O'Grada for his comments on the earlier version of the paper (UMO-2015/17/B/HS4/01000).

REFERENCES

- [1] **D. Acemoglu, J. Robinson**, *Why Nations Fail: The Origins of Power, Prosperity and Poverty*, Crown Business, 2013.
- [2] **K. Andrews, E. Zivot**, *Journal of Business and Economic Statistics*. Further Evidence On The Great Crash, The Oil Price Shock, and The Unit Root Hypothesis. (1010) (1992) 51–70.
- [3] **L. Balcerowicz, A. Rzońca**, *The World Bank. Puzzles of Economic Growth*, 2014.
- [4] **N.S. Balke, T.B. Fomby**, *International Economic Review*, Threshold cointegration. (38) (1997) 627–645.
- [5] **J. Bradley, A. Hannan**, *Journal of Common Market Studies*, The Single Market, the Structural Funds and Ireland's Recent Economic Growth. (393) (2001) 537–552.
- [6] **F. Barry**, *The Celtic Tiger Era: Delayed Convergence or Economic Boom? ESRI Quarterly Economic Commentary*, The Economic and Social Research Institute (2002).
- [7] **J.E. Birnie**, *Can the Celtic Tiger Cross the Irish Border?* Cork University Press (2001).
- [8] **J. Bruzda**, *Procesy nieliniowe i zależności długookresowe w ekonomii. Analiza kointegracji nieliniowej*, Wydawnictwo UMK (2007).
- [9] **M. Cassidy**, *Central Bank of Ireland Quarterly Bulletin*. Productivity in Ireland: trends and issues (2004) 83–106.

- [10] **D.A. Dickey, W.A. Fuller**, Journal of American Statistical Association. Distributions of the Estimators for Autoregressive Time Series with a Unit Root (1979) 427–481.
- [11] **S. Durlauf**, Econometric Analysis and the Study of Economic Growth: A Skeptical Perspective, In: Macroeconomics and the Real World, R. Backhouse and A. Salanti eds., Oxford University Press (2000).
- [12] **S. Durlauf, P. Johnson, J. Temple**, In: P. Aghion, S. Durlauf eds, Handbook of Economic Growth. Growth Econometrics, North Holland (2005) 555–677.
- [13] **W. Enders, P.L. Siklos**, Journal of Business & Economic Statistics. Cointegration and Threshold Adjustment, (192) (2001) 166–176.
- [14] **P. Honohan, B. Walsh**, Human Development report. Catching up with the leaders: the Irish hare. Brookings papers on economic activity, 2002.
- [15] **G. Kapetanios, Y. Shin, A. Snall**, Econometric Theory. Testing for Cointegration in Nonlinear Smooth Transition, Error Correction Models, (226) (2006) 279–303.
- [16] **J. Kelly, M. Everett**, Quarterly Bulletin Article. Financial liberalization and economic growth in Ireland. Central Bank and Financial Services Authority of Ireland (2004) 91–112.
- [17] **D. Kwiatkowski, P.C.B Phillips, P. Schmidt, Y. Shin**, Journal of Econometrics, Testing the Null Hypothesis of Stationary against the Alternative of a Unit Root, (54) (1992) 159–178.
- [18] **J.W. O’Hearn**, Inside the Celtic Tiger; Economy and the Asian Model Contemporary Irish Studies, Pluto Press (1998).
- [19] **J.W. O’Hagan, C. Newman**, The Economy of Ireland. 9th ed. (2005).
- [20] **E. O’Leary**, Irish Economic Development, Taylor & Francis (2015).
- [21] **P. Phillips, P. Perron**, Biometrika, Testing for a Unit Root in Time Series Regression, (752) (1988) 335–346.
- [22] **A. Piński**, Zakazane bogactwo, Wydawnictwo Penelopa Warsaw (2013).
- [23] **G. Przeslawska**, Integracja gospodarcza w rozszerzonej UE: od wolnego handlu do unii walutowej J. Kundery eds. Irlandia – Polska. Instytucjonalne determinanty rozwoju społeczno-gospodarczego (2009) 443–457.
- [24] **R.E. Quandt**, Journal of the American Statistical Association, Tests of Hypotheses that a Linear System Obeys Two Separate Regimes, (55) (1960) 324–330.
- [25] **J. Woo, M.S. Kumar**, Economica, Public debt and growth, (82328) (2015) 705-739.
- [26] **M. Szczepaniak**, Irlandia. Przemiany gospodarcze, Wyd. CeDeWu Warsaw (2015).

Boehlke J.B. E-mail: jurekbo@umk.pl

Faldzinski M.F. E-mail: marf@umk.pl

Galecki M.G. E-mail: mgalecki@umk.pl

Osinska M.O. E-mail: emo@umk.pl

СПИСОК ЛИТЕРАТУРЫ

- [1] **Acemoglu D., Robinson J.** Why Nations Fail: The Origins of Power, Prosperity and Poverty, Crown Business, 2013.
- [2] **Andrews K., Zivot E.** Further Evidence On The Great Crash, The Oil Price Shock, and The Unit Root Hypothesis // Journal of Business and Economic Statistics. 1992. No. 10(10). Pp 51–70.
- [3] **Balcerowicz L., Rzońca A.** Puzzles of Economic Growth, The World Bank, 2014.
- [4] **Balke N.S., Fomby T.B.** Threshold cointegration // International Economic Review. 1997. No. 38. Pp. 627–645.
- [5] **Bradley J., Hannan A.** The Single Market, the Structural Funds and Ireland’s Recent Economic Growth // Journal of Common Market Studies. 2001. No. 39(3). Pp. 537–552.
- [6] **Barry F.** The Celtic Tiger Era: Delayed Convergence or Economic Boom? ESRI Quarterly Economic Commentary. Dublin: The Economic and Social Research Institute, 2002.
- [7] **Birnie J.E.** Can the Celtic Tiger Cross the Irish Border? Cork University Press, 2001.
- [8] **Bruzda J.** Procesy nieliniowe i zależności długookresowe w ekonomii. Analiza kointegracji nieliniowej. Toruń: Wydawnictwo UMK, 2007.
- [9] **Cassidy M.** Productivity in Ireland: trends and issues. Central Bank of Ireland Quarterly Bulletin, 2004. Pp. 83–106.
- [10] **Dickey D.A., Fuller W.A.** Distributions of the Estimators for Autoregressive Time Series with a Unit Root // Journal of American Statistical Association. 1979. No. 74(366). Pp. 427–481.
- [11] **Durlauf S.** Econometric Analysis and the Study of Economic Growth: A Skeptical Perspective // In: Macroeconomics and the Real World, R. Backhouse and A. Salanti (eds). Oxford: Oxford University Press, 2000.
- [12] **Durlauf S., Johnson P., Temple J.** Growth Econometrics // In P. Aghion and S. Durlauf (eds), Handbook of Economic Growth. North Holland, 2005. Pp. 555–677.
- [13] **Enders W., Siklos P.L.** Cointegration and Threshold Adjustment // Journal of Business & Economic Statistics. 2001. No. 19(2). Pp. 166–176.
- [14] **Honohan P., Walsh B.** Catching up with the leaders: the Irish hare. Brookings papers on economic activity, Human Development report, 2002.

- [15] **Kapetanios G., Shin Y., Snall A.** Testing for Cointegration in Nonlinear Smooth Transition Error Correction Models // *Econometric Theory*. 2006. No. 22(6). Pp. 279–303.
- [16] **Kelly J., Everett M.** Financial liberalisation and economic growth in Ireland. Central Bank and Financial Services Authority of Ireland, Quarterly Bulletin Article, 2004. Pp. 91–112.
- [17] **Kwiatkowski D., Phillips P.C.B, Schmidt P., Shin Y.** Testing the Null Hypothesis of Stationary against the Alternative of a Unit Root, *Journal of Econometrics*. 1992. No. 54. Pp. 159–178.
- [18] **O’Hearn J.W.** Inside the Celtic Tiger; Economy and the Asian Model (Contemporary Irish Studies). Pluto Press, 1998.
- [19] **O’Hagan J.W., Newman C.** The Economy of Ireland. 9th ed., 2005.
- [20] **O’Leary E.** Irish Economic Development. Taylor & Francis, 2015.
- [21] **Phillips P., Perron P.** Testing for a Unit Root in Time Series Regression // *Biometrika*. 1988. No. 75(2). Pp. 335–346.
- [22] **Piński A.** Zakazane bogactwo. Warszawa: Wydawnictwo Penelopa, 2013.
- [23] **Przesławska G.** Irlandia – Polska. Instytucjonalne determinanty rozwoju społeczno-gospodarczego // In: Integracja gospodarcza w rozszerzonej UE: od wolnego handlu do unii walutowej, J. Kundery (eds), 2009. Pp. 443–457.
- [24] **Quandt R.E.** Tests of Hypotheses that a Linear System Obeys Two Separate Regimes // *Journal of the American Statistical Association*. 1960. No. 55. Pp. 324–330.
- [25] **Szczepaniak M.** Irlandia. Przemiany gospodarcze. Warszawa: Wyd. CeDeWu, 2015.
- [26] **Woo J., Kumar M.S.** Public debt and growth // *Economica*. 2015. No. 82(328). Pp. 705–739.

Бёльке Е. E-mail: jurekbo@umk.pl

Фалдзинский М. E-mail: marf@umk.pl

Галецкий М. E-mail: mgalecki@umk.pl

Осинска М. E-mail: emo@umk.pl

Статья поступила в редакцию 24.01.17

DOI: 10.18721/JE.10202
UDC 336.25

DIRECTIONS OF IMPROVING THE PUBLIC PROCUREMENT SYSTEM IN THE RUSSIAN FEDERATION

A.I. Aleksandrova, E.A. Ostapovets, A.V. Klochkova

St.Petersburg National Research University of Information Technologies, Mechanics and Optics,
St. Petersburg, Russian Federation

Problems and development issues of the state of the procurement system in the Russian Federation are analyzed in the paper. The state (municipal) order as a competitive method for the determination of the contractor (supplier) is considered in order to formulate its optimal characteristics and competition (bidding) as the best method to select the contractor (supplier). The methods of increasing economic interest of private organizations in public services provision are examined. The differentiation of public services prices as a tool of increasing economic interest is researched in two aspects: differentiation of prices on public services based on standards and division of public service rates by groups of agents (suppliers). The barriers hindering the access of non-governmental organizations to public service markets are identified. Also the analysis of normative regulation of the public procurement system and its disadvantages, statistical data, problems encountered by the participants is done. The actions of customers and suppliers are considered to identify the presence of weak points in the legislation. The costs incurred by customers including mandatory staff training, preparation of extracts from USRLE, certificate of origin ST-1 form, obtaining digital signatures, postage are analyzed. The ROS and UIS systems and their new options useful for participants are compared. The method of assessment of contracts for monetary and non-monetary criteria is proposed. International practice of state procurement is investigated; the public procurement system of the Russian Federation is evaluated by objective indicators, the main directions limiting access of foreign companies to the public procurement market are identified. The combined analysis included a comparison of the public procurement systems of the Russian Federation and countries of the Organization for Economic Cooperation and Development (OECD) as a group of countries with the highest incomes per capita.

Keywords: public procurement system; state regulation; public procurement; international experience; competitive procedures; barriers; public services; state (municipal) order; evaluation

Citation: A.I. Aleksandrova, E.A. Ostapovets, A.V. Klochkova Directions of improving the public procurement system in the Russian Federation, St. Petersburg State Polytechnical University Journal. Economics, 10 (2) (2017) 21–32. DOI: 10.18721/JE.10202

НАПРАВЛЕНИЯ СОВЕРШЕНСТВОВАНИЯ СИСТЕМЫ ГОСУДАРСТВЕННЫХ ЗАКУПОК В РОССИЙСКОЙ ФЕДЕРАЦИИ

А.И. Александрова, Е.А. Остаповец, А.В. Клочкова

Санкт-Петербургский национальный исследовательский университет информационных технологий, механики и оптики, Санкт-Петербург, Российская Федерация

Анализируются проблемы и развитие системы государственных закупок. Рассматриваются государственный (муниципальный) заказ на предмет выработки его оптимальных характеристик как конкурентного способа определения исполнителя (поставщика), а также конкурс как наиболее оптимальный способ определения исполнителя (поставщика). Изучены методы повышения экономической заинтересо-

ванности негосударственных организаций в оказании госуслуг. Исследована дифференциация цен госуслуг как инструмента повышения данной заинтересованности по двум направлениям: разграничение цен госуслуг на основе стандартов и разделение цен госуслуг по группам исполнителей (поставщиков). Выявлены барьеры, препятствующие выходу негосударственных организаций на рынок госуслуг. Также проведен анализ нормативного регулирования системы государственного заказа и недостатков этой системы, статистических данных, проблем, с которыми сталкиваются участники. Рассмотрены действия заказчиков и поставщиков на предмет наличия узких мест в законодательстве. Проанализированы издержки заказчиков: обязательное обучение сотрудников, получение выписок из ЕГРЮЛ, сертификат о происхождении товаров формы СТ-1, получение электронной подписи, почтовые отправления. Проводится сравнительный анализ систем ЕИС и ООС на предмет новых функций, облегчающих процесс закупок для его участников. Предложен способ оценки заказов по стоимостным и нестоимостным критериям, изучен мировой опыт госзакупок, проведена оценка системы госзакупок Российской Федерации по объективным показателям, определены инструменты, ограничивающие доступ иностранных компаний на рынок госзакупок. Проведено сравнение систем государственных закупок Российской Федерации и стран Организации экономического сотрудничества и развития (ОЭСР) как группы стран с самыми высокими доходами на душу населения.

Ключевые слова: система государственных закупок; государственное регулирование; международный опыт; конкурсная процедура; барьеры; государственные услуги; государственный (муниципальный) заказ; оценка

Ссылка при цитировании: Александрова А.И., Остаповец Е.А., Ключкова А.В. Направления совершенствования системы государственных закупок в Российской Федерации // Научно-технические ведомости СПбГПУ. Экономические науки. 2017. Т. 10. № 2. С. 21–32. DOI: 10.18721/JE.10202

Introduction. Public procurement is the most important tool of state regulation contributing to the creation of competitive environment, effective expenditure of budgetary funds, provision of high quality products to consumers. The problems of the public procurement system in Russia are studied in various scientific articles, especially by such authors as Bastrykin, Kradinov, Pershin, Tasalov, Usenkova, Fedorov, Habaev, Yastrebova and others. Issues comparison of international experience of public procurement devoted articles of Belova, Konosco, Alekseeva and Jaworski. Noting the importance of the obtained results, obviously, improving the public procurement system is an unexplored and relevant topic for the study.

Public procurement constitutes a significant proportion of the gross domestic product (GDP) in the vast majority of countries. In OECD countries this indicator varies in the range of 10–15 %, in developing countries it can reach 25 %, and in transition economies – 30 %, and even more [5]. Legislative framework of the public procurement system in Russia is aimed at introduction of new forms of state (municipal) social services, ensuring involvement of non-governmental organizations in provision of

specified services, as well as at the endowment of highest executive bodies of state authorities (local governments) with the right to choose independently the form of services provision focusing on consumer needs and development of the region's economic potential [9].

Contemporary international law on state procurement is based on the Model Law of the United Nations Commission on international trade law (UNCITRAL), which contains 57 clauses that are grouped into 6 chapters: general provisions; methods of procurement and their conditions for use; bidding procedures; the procurement method; the procedures used for procurements through alternative methods; appeal/claims [6].

As international experience shows, the most efficient form of organizing large-scale procurement of goods and services is conducting open competitions (tenders). Application of the remaining two directions – auction and request for quotations – will not be effective due to the fact that the only criterion for selection of suppliers (contractors, performers) is the monetary one, while for public legal entities in public services the priority is service accessibility and quality. Analysis of the Russian Federation

legislation concerning the contract system in procurement has allowed to ascertain the presence of tools for protection of customer interests, the use of which is justified and is within the framework of the state order.

The aim of this research is to analyze the Russian system of public procurement on the subject of its advantages and disadvantages and propose directions of improving it.

Public procurement: existing problems and directions of their solution. The analysis of procurement helped to develop the most optimal characteristics of the state (municipal) order as a competitive method for the contractor (supplier) selection. These include:

- method and requirements of the contractor (supplier) selection;
- the method of determination of public services cost;
- approaches to competitive procedures evaluation;
- tools to mitigate risks of failure or improper execution of state (municipal) order by the service provider (supplier).

In our opinion, the best method to select the contractor (supplier) is competition (bidding). It allows comprehensive evaluation of potential suppliers (executors), in particular, evaluation of applications of competitive procedures participants by monetary and non-monetary criteria. In addition, the possibility of using different competition types allows to take into consideration the specifics of certain public services provision [7].

One of the key barriers hindering the access of non-governmental organizations to the public services market, in our opinion, is the lack of economic interest from these organizations. This negative aspect can be overcome through determination of economically justified cost of public services.

In the current situation economic interest of organizations in public services provision can be promoted by expanding the list of expenses included in services cost. It is important for customers to analyze best practices in this parameter calculation. This experience should include the normative-per capita funding in higher education [12].

One of the directions of increasing this interest is differentiation of public service prices according to their quality in two aspects:

- differentiation of public service prices based on standards. A differentiated standard means

tiered pricing of public services. In this case there is a need to define outcome indicators of public service delivery, which allows to compare their different quality levels;

- division of public service rates by groups of agents (suppliers). In this case, it is necessary to divide executors (suppliers) into several groups depending on public services quality.

It is necessary to ensure free access to tender announcements and documentation for potential participants. They should contain information that enables stakeholders to make management decisions about participation in the competition [9].

The following aspects should be identified in the supplier selection and evaluation:

- whether the consumer is satisfied with the quality of services and material resources to be provided;
- whether the required supply scope, delivery terms, price and service level, new products development for expanding the range of goods that bring profit to the enterprise is ensured;
- whether the complex of measures on pricing and material resources distribution is effective.

Long-term relationships with suppliers play an important role and ensure great results. Such relationships lead to increased sales and increased company profits. Relying on a long-term relationship with a suppliers, a firm should take into consideration their financial status, product quality, technical capabilities, etc. [23].

In developing approaches to this process, a potential list of evaluation criteria is to be identified first.

Two methods are applicable to the state (municipal) order:

- evaluation by cost and non-monetary criteria;
- assessment only by non-monetary criteria.

The right to choose a particular method, in our opinion, should be secured for the customer. It is also necessary to impose certain restrictions at the legislative level, which may constitute:

- the list of services in respect of which only non-monetary criteria can be applied;
- a threshold for contract price reduction. For example, the initial maximum contract price can be reduced by a participant by no more than 10 %. This approach is more optimal for state (municipal) order than the one specified by the Federal law of 05.04.2013 N 44-FZ On Anti-dumping Measures during the Competition/tender [14];

– threshold value for the importance factor of the cost criterion. For example, it should not exceed 0.15.

If the bidder evaluation applies both monetary and non-monetary criteria, the customer should determine:

- reduction threshold of the contract price;
- the importance factor of the cost criterion;
- the cost criterion scoring;
- non-monetary evaluation criteria of the application;
- the importance factor of non-monetary evaluation criteria;
- performance of non-monetary evaluation criteria;
- significance coefficients of these indicators;
- score values of non-monetary criteria.

When determining the list of non-monetary criteria for tender applications, it should be kept in mind that it is necessary to create equal competitive conditions for public organizations having experience of public services and non-governmental ones without such experience. In this regard, it is appropriate to apply the following non-monetary criteria in the framework of the state (municipal) order:

- availability of labor resources;
- qualification of managers and key specialists for public services provision;
- provision of material and technical resources.

These criteria can be supplemented, for example, by an indicator characterizing the necessary logistical resources. The evaluation should be based on the depreciation ratio, which should be related not to the whole organization but to groups of basic assets.

This approach will allow to more accurately assess the condition of the material and technological resources of the procurement participant.

Possible significant social and economic consequences of failure or improper execution of the contractor (supplier) obligations require the development of tools to reduce the risks of such situations occurrence. Reimbursement methods are the most time-consuming aspects of risk mitigation, but they are also the most effective ones. The method consists in regular design, development and evaluation of the future state of the enterprise and its external environment, which requires special analysis and accuracy, ensuring its application efficiency [23].

The performed analysis concerning the fulfillment of obligations in state (municipal) contracts indicated the need to use the same tools for state (municipal) orders. Besides, other means to prevent negative consequences of non-fulfillment or improper fulfillment of commitments by the contractor (supplier) also include:

- the customer's right to unilateral contract termination in case of improper provision of public services;
- the possibility of applying the simplified procedure of selecting a new contractor (supplier) in case of unilateral contract termination. For example, the possibility of signing a contract with the participant taking the second place in the competition; substantial penalties against the contractor (supplier) in case of violation of essential contract terms;
- in certain cases listing agents (suppliers) in the register of unfair contractors (or suppliers) [9].

The analysis of normative regulation of the public procurement system. In Russian Federation, the formation of the basic institutions of the contract system was completed by 90 % in 2015 including: procurement justification and planning, regulation, information management and monitoring, personnel training in procurement sphere. It is advisable to identify what is currently missing from the regulatory system. For this purpose we consider the actions of customers and suppliers to identify the presence of weak points in the legislation. Let us start with customer behavior analysis.

In 2014, 2 781 706 announcements for a total amount of about of 6.02 trillion RUB were placed. In 2015, customers placed more than 3 million announcements worth about 6.6 trillion rubles on the official website. By the end of 2015, the total volume of announcements exceeded the same indicator of 2014 by 9.6 %.

It should be noted that according to statistics, the total number of closed tenders and auctions placed in the public domain significantly increased in 2015 [8]. Such procedures allow to contract on a competitive basis an unlimited range of parties that have a license for admission to work with information constituting state secrets.

In value terms the volume of these procedures compared to last year's data has increased by more than 5 times. Previously, such

transactions were conducted entirely behind closed doors with participation of a limited number of persons to whom customers used to send written invitations.

The predominant method of supplier selection in 2015 was an *electronic auction/bidding*, which accounts for 56.6 % of the total number of announcements available on the official website.

The average price of a contract in 2015 amounted to 1.64 million RUB, in 2014 – 1.98 million RUB. Customers were advised to sign several short-term contracts instead of long-term contracts in order to reduce their risk of contract default by suppliers in volatile markets.

In 2015, 495079 contracts worth more than 1.15 trillion RUB were terminated, exceeding the corresponding figures of 2014 by 34 % and 31 % respectively. In 2014, 370,664 contracts for about 876.9 billion rubles were terminated. Contract termination was mainly performed by agreement of the parties (98 % of the total number of terminated contracts), the bulk proportion being contracts for provision of utility services, communication services, electricity supply, that were terminated due to incomplete volumes of the contracted services.

The increase in the total volume of the contracts terminated by customer's decision by the end of 2015 amounted to 31 %. This means that about 11,000 purchases worth 198 billion rubles can be considered ineffective, which is 3.7 % of the procurement volume.

The obtained data indicate positive dynamics of monetary savings in 2015, the total savings amounting to more than 321 billion rubles, which is about 7 % of the total procurement.

Also in 2014, 683,047 offers were placed in the amount of 476.6 billion rubles, the average contract price with small businesses (SB) and socially oriented nonprofit organizations (SO NPO) in 2014 was 558.7 thousand rubles.

In 2015 SMB, SO NPO hosted 869,590 bids with total value of about 637,5 billion rubles, which is 27 % and 34 %, respectively, higher than the indicators for 2014. The average price of the contracts signed with SB and NPO, at the end of 2015 remained at the 2014 level and amounted to 557,000 rubles.

The contract system has become an effective mechanism to support SB. So, small businesses received more than 490 billion rubles only as

direct contracts payment, which is 41 % higher than in 2014.

According to preliminary estimates, the set 15 % quota of purchases from small businesses including subcontracting agreements was fully executed. In 2015, the average number of applications from procurement participants per one supplier selection procedure among SMB, SO NPO was 3.1, which exceeds the same indicator of the previous year (2 applications) by 1.5 times .

The volume of contracts signed with a single supplier grew by 4 % at the end of 2015 and amounted to 1141,6 billion rubles.

The increased procurement volume from a single supplier was mainly due to procurement growth:

- utilities and services of natural monopolies related to growth rates;
- by separate decisions;
- institutions and enterprises of the penal system.

«*The single application index*» is an indicator calculated as the relative value of one procurement participation application to the total number of purchases during the reported period.

By the end of 2015, there was a noticeable decrease in the volume of purchases from a single supplier calculated on the basis of failed procedures data. In the first quarter of 2015, there was a significant increase of such purchases (up to 25 % in April 2015). Since June 2015, the value of the single application index was relatively low, amounting to 5 % in December of 2015, which is almost 3 times less than in December of 2014.

Let us consider supplier behavior statistics. The average number of submitted applications for procurement participation increased from 2.5 in 2014 to 3 applications at the end of 2015.

The most competitive method of supplier selection is a two-stage competition, for which on average 5.95 bids were filed in 2015, the least competitive one is request for proposals, for which an average of 1.27 applications was filed in 2015.

Procurements worth less than 10 million rubles account for the maximum number of bidders. The lowest procurement demand is the contracts with the maximum starting price (MSPC) over 500 million rubles.

Let us consider the *costs incurred by the customers*.

Mandatory staff training

Procurement activities involved about 900,000 customer employees. Every year about one third of all procurement staff are to be trained. With an average training course cost of 15,000 rubles, the annual expenses amount to about 4.5 billion rubles.

The implementation of the professionalism principle inherent to the contract system and the legal requirement of mandatory customer staff training led to the emergence of a «grey market» of documents certifying professional development.

The problem can be solved by regular customer staff assessment performed on the basis of regional certified universities or, alternatively, certification required only for those professionals who have the right to make key purchasing decisions.

Preparation of extracts from USRLE

In 2015, approximately 2.5 billion rubles were spent to receive extracts from the Unified State Register of Legal Entities (USRLE).

Integration of UIS to register will completely eliminate such expenses because customers will be able to obtain the necessary information about the participant's procurement activities in an automatic mode.

Certificate of origin ST-1 form

Confirmation of the country of origin is a certificate of origin issued by an authorized body (organization) of a member state of the Eurasian Economic Union in ST-1 form.

About 250,000 contracts are based on procurement results with the application of national procurement procedures. Given that in 2015, the average number of bidders in 1 procedure was 3 participants with the certificate price of about 2,000 rubles, the total document acquisition expenses in the reported year amounted to about 1 billion rubles.

Obtaining digital signatures

In 2015, procurement participants spent at least 1.5 billion rubles on DSs. These expenses can be eliminated by providing, for example, the possibility to use a single digital signature on all electronic trading platforms.

Postage

In 2015, in accordance with Russian post tariffs procurement, participants spent about 1 billion rubles for postage of participation applications.

Thus, only the listed examples of expenses in aggregate amounted to more than 10 billion rubles per year. However, the transition to modern e-procurement technology will drastically reduce transaction costs [8].

Comparative analysis of ROS and UIS.

Significant changes have recently occurred in the field of public procurement in Russia. Thus, since 1 January 2016 the unified information system in procurement (UIS) was introduced, this was accompanied by decommissioning the official website of the Russian Federation for posting information about placing of orders for goods deliveries, works performance and services rendering on the Internet (ROS). Since the UIS was built on the basis of ROS, it has retained the same domain address in the Internet: zakupki.gov.ru.

UIS introduction has significantly simplified the work of all those who by the nature of their professional activities are engaged in procurement.

New options were added:

- automatic monitoring to limit posting the protocols of the first and second stages of public procurement discussion before the end of this discussion stage;
- automatic generation of Protocol violations on the basis of automated monitoring and display Protocol in ROS UIS;
- receiving and processing complaints;
- search for complaints and the results of their consideration;
- transmission of claim information and unscheduled inspections of departmental facilities;
- design of new types of unplanned and planned monitoring activities and testing results;
- recording of inspection results and report on new types of unplanned and planned monitoring activities (audit, inspection);
- advanced part search details;
- auto detect user location and user location data when searching for procurement information;
- posting draft procurement plans and draft changes to the procurement plan
- automatic generation of notifications in the personal account of JSC «Federal Corporation for development of small and medium enterprises» (hereinafter – the Corporation) on the location of the project procurement plan and the approved procurement plan for conformity assessment [18]

The Federal Law No.44 «On the contract system in the sphere of procurement of goods, works, services for state and municipal needs» is one of the most recently amended laws. Let us consider the changes in this Law from the beginning of 2017:¹

- in UIS the complete correspondence of the information placed in the system and all documentation relating to the state contract is monitored. For example, the compliance of the terms of the state contract with the information about it placed in the register of contracts;
- the importance of scheduled plans increases (a ban on purchases not included in these schedules is introduced);
- the name of the subject of public procurement must be taken from a special catalog (in cases specified by the law);
- the identification code of the e-procurement, introduced from 2016, now must be placed in all documents of the state contract;
- typical conditions of state contracts for procurement from small businesses and socially-oriented non-profit organizations (SONKO) are introduced.

The world experience of public procurement. In order to better understand the prospects of development of the contracting system in Russia let us consider the features of public procurement systems in various countries. In 2016, a study «Comparative analysis of public procurement in 2016» covering 77 countries was conducted, which includes information concerning public procurement systems accessibility, barriers reduction, transparency and efficiency improvement in this sector [10].

For a comprehensive analysis of objective and subjective indicators, a combined investigation was carried out, which represents an average score by the sum of subjective indicators and fair value of an objective indicator. A fair objective indicator assessment is a measurable parameter that is aimed at averaging the objective value by assigning a score from 20 to 100 depending on duration of the complaint consideration.

¹ Federalnyj zakon nomer 44 (FZ ot 05.04.2013, redakciya ot 22 Fevralya, 2017) «O kontraktnoj sisteme v sfere zakupok tovarov, rabot, uslug dlja obespechenija gosudarstvennyh i municipal'nyh nuzhd». URL: http://www.consultant.ru/document/cons_doc_LAW_144624/

The combined analysis included a comparison of the public procurement systems of the Russian Federation and countries of the Organization for Economic Cooperation and Development (OECD) as a group of countries with the highest incomes per capita.

The results of the analysis show that the contract system in Russia corresponds to the highest international standards.

Let us consider the evaluation of the public procurement system of the Russian Federation according to *subjective indicators*.

Research methods include analysis of normative-legal regulation and practice of participation in public procurement of entities by the following indicators:

- accessibility of the public procurement system, including:
 - preparation of the application: availability of information about upcoming and current opportunities to participate in the procurement process, clarity and understanding of the regulatory framework;
 - application submission and evaluation: ensuring a fair and transparent process of proposal preparation, understanding the bid evaluation mechanism, bids opening and evaluation;
 - contract award and execution: assessment of contract transparency after the supplier (contractor, executor) selection; notification of the losing party about the customer decision to award a contract with the winner;
 - a monitoring and claim mechanism;
 - implementation of the monitoring and claim mechanism.

The public procurement system of the Russian Federation has received a high expert assessment, with the highest score (81 points or more) rating in terms of «submission and evaluation of claims», «claims to the monitoring body».

The experts evaluated as «good» (score of 61 and more) such indicators as «award and execution of contract, «requisitions preparation», implementation of a monitoring and claim mechanism».

The rating of the public procurement system of the Russian Federation based on *objective indicators* should also be considered.

The results of the study also include the assessment of the terms of the complaint of the supplier (contractor, performer) about the actions (inaction) of the customer. In this case,

the terms established by the law on public procurement, as well as the actual terms of complaint consideration by the supervisory body are taken into account.

The study shows that Russian Federation has one of the most effective claim consideration systems in the field of public procurement. It should be noted that there is no available information concerning claim consideration terms for some OECD member countries (such as Sweden, France, Australia, Canada, the Netherlands).

The study of the Russian public procurement system can lead to the following conclusions.

Among the positive conclusions, the following should be noted:

- in Russia, there are no legal fees for claim consideration paid to the supervisory body, while in many countries, such fees can reach up to 37 % of the contract value;
- the contract system of the Russian Federation was awarded the highest points for all aspects and is on equal ground with such countries as the USA, the UK, Korea and Singapore;
- contract system legislation of the Russian Federation provides the necessary mechanisms for adequate security, transparency and efficiency of the procurement process and the necessary accountability measures.

As a limitation, it should be noted that Russia currently does not implement a mechanism for granting the participants of procurement activities the rights to inform about the known collusion and other violations in procurement procedures. Such a mechanism has already been implemented in Chile, Malaysia, Mongolia, Nigeria and Peru. The necessary measures to protect reporting agents operate in most countries. Only in 11 out of the surveyed 77 countries, there are no protective mechanisms. Protective measures do not exist in Azerbaijan, the Democratic Republic of the Congo, Côte d'Ivoire, Egypt, Kyrgyz Republic, Lebanon, Myanmar, Nicaragua, the Philippines, Thailand and Togo.

Thus, as a result of this study, the following directions of improving the public procurement system in Russia are suggested:

1. It is necessary to increase the economic interest of organizations in the provision of public services by expanding the list of expenses included in the cost of services. One of the directions of increasing this interest is differentiation of public services prices according

to their quality in two aspects: differentiation of public services prices based on standards and division of public services rates by groups of performers (suppliers).

2. For potential participants it is necessary to ensure free access to tender announcements and documentation for potential participants.

3. When assessing and choosing a supplier, a potential list of evaluation criteria must first be identified. Two methods are applicable to the state (municipal) order: evaluation by cost and non-monetary criteria and assessment only by non-monetary criteria.

4. Tools to reduce risks such as reimbursement methods should be developed.

5. Besides, other means to prevent negative consequences of non-fulfillment or improper fulfillment of commitments by the contractor (supplier).

6. The costs incurred by customers should also be taken into account and reduced whenever possible: mandatory staff training, preparation of extracts from USRLE (integration of UIS to register will completely eliminate such expenses), certificates, obtaining digital signatures, postage and others.

7. Improving the UIS (Unified information system). Currently, according to part 23 of article 34 of the Federal Law No. 44, information about subcontractors and co-executors of large contracts is provided to the customer, but is not disclosed publicly. This provision of the law is applied to contracts with an initial (maximum) price more than 1 billion rubles in order to meet federal needs and 100 million rubles to meet the needs of the subjects of the Russian Federation and municipal needs (Government Decree No. 775 of September 4, 2013)² It is necessary to lower the price threshold of contracts in order to disclose information on subcontractors and co-executors. The obligation to place information about the subcontractor's involvement of executors of the contract in the unified information system

² Postanovlenie Pravitel'stva RF ot 04.09.2013 g. No. 775 (red. ot 27.03.2014) «Ob ustanovlenii razmera nachal'noj (maksimal'noj) ceny kontrakta pri osushhestvlenii zakupki tovara, raboty, uslugi, pri prevyshenii kotoroj v kontrakte ustanavlivaetsja objazannost' postavshhika (podrjadchika, ispolnitelja) predostavljat' zakazchiku dopolnitel'nuju informaciju». DOI=<http://base.garant.ru/70447332/>

should be provided. This mechanism will ensure the spread of public control to the sphere of relations between contractors (general contractors) on state and municipal contracts with subcontractors, co-executors, and will make public the facts of attracting unscrupulous agents. A number of corruption schemes can be implemented through intermediary relations. The most effective tool for identifying and combating corruption is the disclosure of information for public control. It is necessary to provide for the disclosure of information about the supervisory's decisions on the coordination or disagreement of the conclusion of contracts with a single supplier (contractor, executor) in order to increase the transparency of procurement and openness and transparency of the control departments.³

8. In addition, a major common problem in the modern practice of public procurement is the «human factor» that breeds corruption and dishonesty. This implies not just occasional bribing of officials, but the merger of government and business, in which selection lobbying plays an increasingly important role along with fair competitive methods of suppliers. A well-designed regulatory framework and competent administration of procurement can provide the solution to the problem. Thus, the lobby may become only one of the selection factors operating in «other things being equal» circumstances, when the procurement system should focus on the basic principles established in foreign procurement practices:

- transparency — openness and accessibility of procurement information;
- accountability and due process — strict adherence to the procurement procedures with state and public monitoring;
- open and effective competition — non-discrimination;
- fairness — equal opportunities for all participants of the procurement process.

9. One of the solutions to the issues in the sphere of legal regulation of procurement information support can be digitization of public procurement based on digital passports of goods

³ Proekt Federal'nogo zakona «O vnesenii izmenenij v Federal'nyj zakon "O kontraktnoj sisteme v sfere zakupok tovarov, rabot, uslug dlja obespechenija gosudarstvennyh i municipal'nyh nuzhd». URL: <http://economy.gov.ru/minec/about/structure/depfks/20160704>

in the GS1 system and electronic document management as a tool of direct assistance to enterprises in export-import activities [13].

10. As for limiting access of foreign companies to the public procurement market, there are three main directions. Firstly, the state may impose a ban on purchase of goods and services from foreign suppliers. Secondly, a state may require foreign producers to use a certain number of local components in their products. Thirdly, the state can pursue a policy of price preferences [19]. In this case, the state sets the allowable difference between the prices of foreign companies and national ones. Only if the price differences exceed the prescribed rate, the government buys foreign products.

The analysis of public procurement systems of some developing countries such China, South Africa, Brazil and Mexico has shown that methods to support domestic producers through public procurement by means of discrimination against foreign companies are widely used in these countries [16].

In the year following Russia's accession to the WTO, work to develop support for domestic producers through public procurement was intensified. In particular, there have been proposals to limit purchases of foreign medicines and medical equipment, certain goods, if their equivalents are produced in Russia. For example, a Draft Resolution of the Russian Federation Government «On Banning Admission of Certain Goods Types in Order Placement for State and Municipal Needs» was developed, in particular, it concerns import of automotive industry products (cars, trucks, buses, trolleybuses, special vehicles).⁴

In conclusion, it should be noted that the public procurement system should simultaneously meet two types of criteria: requirements for state contracts management and economic policy goals [21]. For the reason that the simultaneous compliance with the requirements for these two types is often simply impossible (for example, promotion of competition and support of small and medium business), the development of a

⁴ Proekt Postanovlenija Pravitel'stva RF «Ob ustanovlenii zapreta na dopusk otdel'nyh vidov tovarov pri razmeshhenii zakazov na postavki dlja gosudarstvennyh i municipal'nyh nuzhd». URL: <http://www.consultant.ru/law/hotdocs/28573.html>

balanced policy of public procurement acquires particular importance.

The following directions for further research can be identified: a deeper analysis of the

normative regulation of public procurement, and the analysis and modeling of working overseas schemes of public procurement in the conditions of the Russian market.

REFERENCES

- [1] O kontraktnoi sisteme v sfere zakupok tovarov, rabot, uslug dlia obespecheniia gosudarstvennykh i munitsipal'nykh nuzhd [On the contract system in procurement of goods, works, services for state and municipal needs], Feder. zakon № 44-FZ ot 05.04.2013 g. (red. ot 22.02.2017). URL: http://www.consultant.ru/document/cons_doc_LAW_144624/
- [2] O vnesenii izmenenii v Federal'nyi zakon «O kontraktnoi sisteme v sfere zakupok tovarov, rabot, uslug dlia obespecheniia gosudarstvennykh i munitsipal'nykh nuzhd» [On amendments to the Federal law «On contract system in procurement of goods, works, services for state and municipal needs»], Proekt Feder. zakona. URL: <http://economy.gov.ru/minec/about/structure/depfks/20160704>
- [3] Ob ustanovlenii razmera nachal'noi (maksimal'noi) tseny kontrakta pri osushchestvlenii zakupki tovara, raboty, uslugi, pri prevyshenii kotoroi v kontrakte ustanavlivaetsia obiazannost' postavshchika (podriadchika, ispolnitelia) predostavliat' zakazchiku dopolnitel'nyu informatsiiu [About establishment of the size of the initial (maximum) contract price at implementation of procurement of goods, works and services, above which the contract establishes the obligation of a supplier (contractor, performer) to provide the customer with additional information], Postan. Pravitel'stva RF № 775 ot 04.09.2013 g. (red. ot 27.03.2014 g.). URL: <http://base.garant.ru/70447332/>
- [4] Ob ustanovlenii zapreta na dopusk otdel'nykh vidov tovarov pri razmeshchenii zakazov na postavki dlia gosudarstvennykh i munitsipal'nykh nuzhd [About the ban on admission of certain types of goods when placing orders for state and municipal needs], Proekt Postan. Pravitel'stva RF. URL: <http://www.consultant.ru/law/hotdocs/28573.html>
- [5] **S. Arrowsmith, S. Treumer, J. Fej, L. Jiang**, Public Procurement Regulation: an Introduction. The EU Asia Inter University Network for Teaching and Research in Public Procurement Regulation, 2010. P. 2.
- [6] **C. Belova**, Goszakupki za rubezhom: obshchee i osobennoe [Procurement abroad: General and special], CRN/RE («IT-biznes»). URL: <http://www.crn.ru/publication/>
- [7] **A.A. Fedorov**, Ustanovlenie trebovaniia k uchastnikam zakupok po Zakonu № 223-FZ [The establishment of requirements to participants of procurement under Law № 223-FZ]. URL: http://roszakupki.ru/upload/documents/2014/Prakticheskaya_konferenciya_2014/14_Fedorov_A_A.pdf
- [8] **A.A. Galkin**, Rezul'taty monitoringa primeneniia Zakona o kontraktnoi sisteme za I–III kvartaly 2015 g. [The results of the monitoring of the implementation of the Law on the contract system for the I–III quarters of 2015], Goszakupki.RU, (1) (2016) 6–17.
- [9] **S.G. Khabaev, P.G. Kradinov**, Perekhod ot formirovaniia goszadaniia k goszakazu na okazanie gosuslug v pol'zu fizicheskikh i iuridicheskikh lits [The transition from the formation of the state assignment to the state order for the provision of government services to individuals and legal entities], Bukhgalterskii uchët v biudzhethnykh i nekommercheskikh organizatsiiakh, (12) (2016).
- [10] International Bank for Reconstruction and Development. The World Bank. Benchmarking public procurement 2016. URL: DOI=<http://bpp.worldbank.org/~media/WBG/BPP/Documents/Reports/Benchmarking-Public-Procurement-2016.pdf?la=en>
- [11] **A.A. Iakovlev, O.A. Demidova, E.A. Podkolzina**, Empiricheskii analiz sistemy goszakupok v Rossii [An empirical analysis of public procurement system in Russia], Izd. dom NIU VShE, Moscow, 2015.
- [12] **O.K. Iastrebova**, Razvitie normativnogo biudzhethnogo finansirovaniia vysshego obrazovaniia [The development of normative budget financing of higher education]. Nauchno-issledovatel'skii finansovyi institut. Finansovyi zhurnal. (1) (2015) 41–51.
- [13] **I.B. Kolysheva**, Normativno-pravovoe i informatsionnoe obespechenie gosudarstvennykh zakupok: rossiiskie realii i zarubezhnyi opyt [Legal and information support of public procurement: Russian realities and foreign experience]. Istoricheskie, filosofskie, politicheskie i iuridicheskie nauki, kul'turologiia i iskusstvovedenie. Voprosy teorii i praktiki. 1(27) (2013) Part II 104–108
- [14] **N. Kurts**, Antidempingovye mery v sfere goszakupok [Anti-dumping measures in public procurement]. URL: <http://barton.ru/antidempingovye-mery-v-sfere-goszakupok.html>
- [15] **A.A. Morozova**, Pravovye problemy obespecheniia ispolneniia obiazatel'stv po gosudarstvennomu (munitsipal'nomu) kontraktu [Legal problems of ensuring performance of obligations on the state (municipal) contract], Publichnye zakupki: problemy pravoprimereniia, Materialy Vserossiiskoi nauchno-praktitseskoi konferentsii, Iustitsinform, Moscow, 2015, 166–171.
- [16] **O.V. Ponomareva**, Gosudarstvennye zakupki kak instrument torgovoi politiki v razvivaiushchikh

stranakh [Public procurement as an instrument of trade policy in developing countries], Rossiiskii vneshneekonomicheskii vestnik, (9) (2014) 101–119.

[17] Reforma goszakupok v Rossii provalilas' [The public procurement reform has failed in Russia?] 25.02.2016, Informatsionno-analiticheskii portal SakhaNews, Ekonomika i biznes. URL: <http://www.isn.ru/160124.html>

[18] Sravnenie OOS i EIS. Tablitsa funktsional'nykh vozmozhnostei [Compare OOS and UIS. Table functionality], Goszakupki.RU, (3) (2016).

[19] F. Ssenoga, Examining discriminatory procurement practices in developing countries, Journal of Public Procurement, 6(3) (2006) 219.

[20] F.A. Tsalov, Sposoby obespecheniia ispolneniia obiazatel'stv po gosudarstvennomu kontraktu: voprosy teorii i praktiki [Ways of providing performance of

obligations on the state contract: theory and practice], Publichnye zakupki: problemy pravoprimereniia, Materialy Vserossiiskoi nauchno-prakticheskoi konferentsii. Moscow, Iustitsinform (2014) 161–162.

[21] K.V. Thai, Challenges in public procurement: An International Perspective. PrAcademics Press, Boca Raton, Florida, USA (2005) 3.

[22] Upravlenie zakupkami v informatsionnoi ekonomike: voprosy teorii i praktiki [Procurement management in the information economy: issues of theory and practice], Monographiia. Pod red. d.e.n. I.I. Smotriskoi, Institut ekonomiki RAN, Moscow, 2014.

[23] G.V. Usenkova, Upravlenie zakupkami, logistika snabzheniia [Management procurement purchasing logistics], Upravlenie sobstvennost'iu: teorii i praktika, (2) (2016).

Aleksandrova A.I. E-mail: aariadna@mail.ru

Ostapovets E.A. E-mail: kateostapovets@gmail.com

Klochkova A.V. E-mail: a.v.klochkova@mail.ru

СПИСОК ЛИТЕРАТУРЫ

[1] О контрактной системе в сфере закупок товаров, работ, услуг для обеспечения государственных и муниципальных нужд : Федер. закон № 44-ФЗ от 05.04.2013 г. (ред. от 22.02.2017). URL: http://www.consultant.ru/document/cons_doc_LAW_144624/

[2] О внесении изменений в Федеральный закон «О контрактной системе в сфере закупок товаров, работ, услуг для обеспечения государственных и муниципальных нужд» : Проект Федер. закона. URL: <http://economy.gov.ru/mines/about/structure/depfs/20160704>

[3] Об установлении размера начальной (максимальной) цены контракта при осуществлении закупки товара, работы, услуги, при превышении которой в контракте устанавливается обязанность поставщика (подрядчика, исполнителя) предоставлять заказчику дополнительную информацию: Постан. Правительства РФ № 775 от 04.09.2013 г. (ред. от 27.03.2014 г.). URL: <http://base.garant.ru/70447332/>

[4] Об установлении запрета на допуск отдельных видов товаров при размещении заказов на поставки для государственных и муниципальных нужд : Проект Постан. Правительства РФ. URL: <http://www.consultant.ru/law/hotdocs/28573.html>

[5] Arrowsmith S., Treumer S., Fej J., Jiang L. Public Procurement Regulation: an Introduction. The EU Asia Inter University Network for Teaching and Research in Public Procurement Regulation, 2010. P. 2.

[6] Белова С. Госзакупки за рубежом: общее и особенное // CRN/RE («ИТ-бизнес»). URL: <http://www.crn.ru/publication/>

[7] Федоров А.А. Установление требований к участникам закупок по Закону № 223-ФЗ. URL: <http://roszakupki.ru/upload/documents/2014/Praktiche>

skaya_konferenciya_2014/14_Fedorov_A_A.pdf

[8] Галкин А.А. Результаты мониторинга применения Закона о контрактной системе за I–III кварталы 2015 г. // Госзакупки.РУ. 2016. № 1. С. 6–17.

[9] Хабаев С.Г., Крадинов П.Г. Переход от формирования госзадания к госзаказу на оказание госуслуг в пользу физических и юридических лиц // Бухгалтерский учет в бюджетных и некоммерческих организациях. 2016. № 12.

[10] International Bank for Reconstruction and Development / The World Bank. Benchmarking public procurement 2016. URL: DOI=<http://bpp.worldbank.org/~media/WBG/BPP/Documents/Reports/Benchmarking-Public-Procurement-2016.pdf?la=en>

[11] Яковлев А.А., Демидова О.А., Подколзина Е.А. Эмпирический анализ системы госзакупок в России. М.: Изд. дом НИУ ВШЭ, 2015.

[12] Ястребова О.К. Развитие нормативного бюджетного финансирования высшего образования // Научно-исследовательский финансовый институт. Финансовый журнал. 2015. № 1. С. 41–51.

[13] Кольшева И.Б. Нормативно-правовое и информационное обеспечение государственных закупок: российские реалии и зарубежный опыт // Исторические, философские, политические и юридические науки, культурология и искусствоведение. Вопросы теории и практики. 2013. № 1(27): в 2 ч. Ч. II. С. 104–108

[14] Курц Н. Антидемпинговые меры в сфере госзакупок. URL: <http://barton.ru/antidempingovymery-v-sfere-goszakupok.html>

[15] Морозова А.А. Правовые проблемы обеспечения исполнения обязательств по государственному

(муниципальному) контракту // Публичные закупки: проблемы правоприменения: матер. Всерос. науч.-практ. конф. М.: Юстицинформ. 2015. С. 166–171.

[16] **Пономарева О.В.** Государственные закупки как инструмент торговой политики в развивающихся странах // Российский внешнеэкономический вестник. 2014. № 9. С. 101–119.

[17] Реформа госзакупок в России провалилась? 25.02.2016 // Информационно-аналитический портал SakhaNews, Экономика и бизнес. URL: <http://www.isn.ru/160124.html>

[18] Сравнение ООС и ЕИС. Таблица функциональных возможностей // Госзакупки.РУ. 2016. № 3.

[19] **Ssenoga F.** Examining discriminatory procurement practices in developing countries // Journal of Public Procurement. 2006. Vol. 6. No. 3. P. 219.

[20] **Тасалов Ф.А.** Способы обеспечения исполнения обязательств по государственному контракту: вопросы теории и практики // Публичные закупки: проблемы правоприменения: матер. Всерос. науч.-практ. конф. М.: Юстицинформ, 2014. С. 161–162.

[21] **Thai K.V.** Challenges in public procurement: An International Perspective. PrAcademics Press, Boca Raton, Florida, USA, 2005. P. 3.

[22] Управление закупками в информационной экономике: вопросы теории и практики: моногр. / под ред. д.э.н. И.И. Смотрицкой. М.: Институт экономики РАН, 2014.

[23] **Усенкова Г.В.** Управление закупками, логистика снабжения // Управление собственностью: теория и практика. 2016. № 2.

Александрова А.И. E-mail: aariadna@mail.ru

Остаповец Е.А. E-mail: kateostapovets@gmail.com

Клочкова А.В. E-mail: a.v.klochkova@mail.ru

Статья поступила в редакцию 20.02.17

DOI: 10.18721/JE.10203
UDC 338.22

INNOVATIONS IN RUSSIAN INDUSTRY: GOVERNMENT SUPPORT, EXPECTATIONS AND REALITY

E.S. Balashova, O.I. Gnezdilova

Peter the Great Saint-Petersburg Polytechnic University, St. Petersburg, Russian Federation

The paper discusses the current trends of Russian technological development. This article reviews the regulatory legal acts in the sphere of industry, innovations and science analytically. As the result, the main problems in Russian legislation and some barriers to innovative development of industry are revealed. Purpose: the authors analyze the current regulatory basis in order to work out some suggestions to improve the mechanisms of regulating and stimulating innovative activity and to provide technological independence. The study used the following techniques: comparative analysis, comprehensive analysis of statistical data, analysis of the federal regulatory legal acts, systematization of the research results. In order to summarize the information, a grouping method is used. Results: the authors have analyzed the current regulatory basis in the sphere of science, industry and innovations; revealed some disadvantages of it and developed the proposals to improve the regulatory basis taking into account the target-oriented approach to organization of innovative strategy. The system of achievement indicators in the program documents has been formulated incorrectly. It is necessary to reconsider this system in the context of the shift in the priorities towards increasing sales of high-technology and science-intensive products by Russian companies of real economy. The analysis of Russian economic trends leads to the conclusion that there is a need to implement an innovative economy. The combination of legal, direct and indirect methods of stimulation in terms of a unified state policy is an effective way to increase innovative activity of Russian companies. The authors have defined the primary targets. If these priority tasks are fulfilled, it will be possible to provide technological independence and national defense capability. The materials of the article may be useful for development of scientific fields in the sphere of innovative development of the industrial sector and also in the practice of government regulation of innovative processes.

Keywords: industry; industrial economics; technological development; innovative strategy; industrial policy; regulatory legal acts; government support; innovative activity; innovations

Citation: E.S. Balashova, O.I. Gnezdilova, Innovations in russian industry: government support, expectations and reality, St. Petersburg State Polytechnical University Journal. Economics, 10 (2) (2017) 33–43. DOI: 10.18721/JE.10203

ИННОВАЦИИ В РОССИЙСКОЙ ПРОМЫШЛЕННОСТИ: ГОСУДАРСТВЕННАЯ ПОДДЕРЖКА, ОЖИДАНИЯ И РЕАЛЬНОСТЬ

Е.С. Балашова, О.И. Гнездилова

Санкт-Петербургский политехнический университет Петра Великого,
Санкт-Петербург, Российская Федерация

Рассмотрены современные тенденции российского технологического развития. Проведен аналитический обзор нормативно-правовых актов в сфере промышленности, инноваций и науки, в результате которого выявлены существующие пробелы

в национальном законодательстве и барьеры инновационного развития промышленности. Цель исследования – анализ действующей нормативно-правовой базы с целью разработки предложений по совершенствованию механизма регулирования и стимулирования инновационной деятельности и вывода страны из группы технологических аутсайдеров. Используются следующие методы: сравнительный анализ, комплексный анализ статистических данных, анализ федеральных нормативно-правовых актов, систематизация результатов исследования. С целью обобщения информации применен метод группировки. Проведен анализ действующего законодательства в области науки, промышленности и инноваций, выявлены недостатки, предложены мероприятия по корректировке с учетом программно-целевого подхода в организации инновационной стратегии. В программных документах система показателей достижения целей сформирована некорректно и требует пересмотра с учетом смещения приоритетов в сторону увеличения объемов продаж высокотехнологичной и наукоемкой продукции российскими компаниями реального сектора экономики. Исследование тенденций развития отечественной экономики приводит к выводу о наличии потребности в ее инновационном развитии. Повышение инновационной активности российских организаций представляется целесообразным путем комбинации методов правового, прямого и косвенного стимулирования в рамках единой государственной политики. Сформулированы первоочередные задачи, решение которых необходимо для вывода России из группы технологических аутсайдеров и обеспечения высокого уровня ее обороноспособности. Материалы исследования могут быть полезны для развития научных направлений в области инновационного развития промышленного сектора экономики, а также в практике государственного регулирования инновационных процессов.

Ключевые слова: промышленность; экономика промышленности; технологическое развитие; инновационная стратегия; промышленная политика; нормативно-правовые акты; государственная поддержка; инновационная активность; инновации

Ссылка при цитировании: Балашова Е.С., Гнездилова О.И. Инновации в российской промышленности: государственная поддержка, ожидания и реальность // Научно-технические ведомости СПбГПУ. Экономические науки. 2017. Т. 10. № 2. С. 33–43. DOI: 10.18721/JE.10203

Introduction. The exhaustion of the raw-materials export model of development determined the modernization of Russian industry and the formation of the National Innovative System. The fallout from long-term orientation of the Russian export to raw materials manifested most clearly with the sharp decline of world oil prices and the implementation of sanctions against Russian Federation by European Union countries (EU) and the United States of America (the US) in relation to the events in Ukraine. In the current unfavorable social and political environment, bridging the technology gap from the advanced countries in the global market of science-intensive and high-technology products and also ensuring the dominant position of our country are necessary for the survival of economy and for providing national defense capability. V.V. Putin made a public statement about successful overachievement of the target for arms export and defense technologies in 2015 (the volume reached 4.5 billion dollars). Nevertheless, the share of arms export was 4.2 % in the total structure of Russian export. It is approximately 11 times less than the export of oil

and petroleum products. A significant increase in arms export is observed in comparison to 2013, but the orientation to raw materials remains dominant.

The government plays a key role in the promotion of innovative activity and providing of Russian industrial growth. An implementation of the industrial policy and different innovative programs is the main tool of the government for regulating and stimulating these processes. However, the current realities testify to the inferiority and inefficiency of the current government support. It is impossible to take a position among the country's group of technological leaders without government support. Mil'skaya [9] and Maksimtsev et al. [8] identify three groups of factors which hinder the growth of innovative activity: economic, internal and other factors. It is important to pay special attention to other factors that include insufficiency of regulatory legal documents with regard to innovative activity regulation and stimulation, poor infrastructure and uncertain benefits of using intellectual property. These aspects confirm the need to reconsider the

current government policy and make significant adjustments taking into account the social, economic and political contexts. The above-mentioned problems and factors determined the relevance of the research topic and allowed the authors to create the problem statement.

Scientific mission. It is necessary to provide an analytical review of the current regulatory basis in the sphere of science, innovations and industry and also to study the Russian economy's major trends and lines of development.

A significant amount of Russian and foreign scientific research which are dedicated to problems of innovative activity [5–7; 21–23] demonstrates the extreme importance of the selected theme. Such scientists as Freeman, Mensh, Nureev, Hayek made a significant contribution to solving the issue of assessing the government's role in innovative processes. Dynkin, Abalkin, Glaz'ev considered the problems of implementing the government regulation and stimulation of innovative activity. Nowadays, many contemporary scientists examine the process of innovative economic development that is based on using the best achievements of science and new technologies produced by Russian companies. As a rule, one part of scientific research is focused on the general analysis of innovative policy and the other is dedicated to a detailed analysis of innovative indicators.

The methodology and results of the study. The methodology of study includes an analytical review of the federal regulatory basis in order to

identify declaratory and factual documents. An analysis of the Russian economy's trends and lines of development in order to work out the mechanism for the withdrawal of Russia from the group of technological outsiders is the other part of this study. The study used techniques such as: comparative analysis of various development strategies, comprehensive analysis of statistical data and grouping method.

The regulatory basis in the sphere of industry, innovations and science is considered at the first stage. The government has developed and adopted a large number of practical documents over the past decade. In accordance with study [2] the federal regulatory basis in the sphere of industry and innovations can be presented as the following system of elements:

1. program documents reflecting the necessity of innovative development of the Russian economy in general and increasing the competitiveness of the Russian industry in particular have outlined the goals and common principles of the government policy in this direction (Fig. 1):

1.1. doctrines

– «On the Doctrine of the Development of Russian Science»

1.2. programs

– Federal target program «Modernization of the Unified System of the Russian Federation of Air Traffic Management (2009–2020)»;

– Federal Target Program «Research and development in priority areas of Russian scientific and technological complex for 2014–2020»;

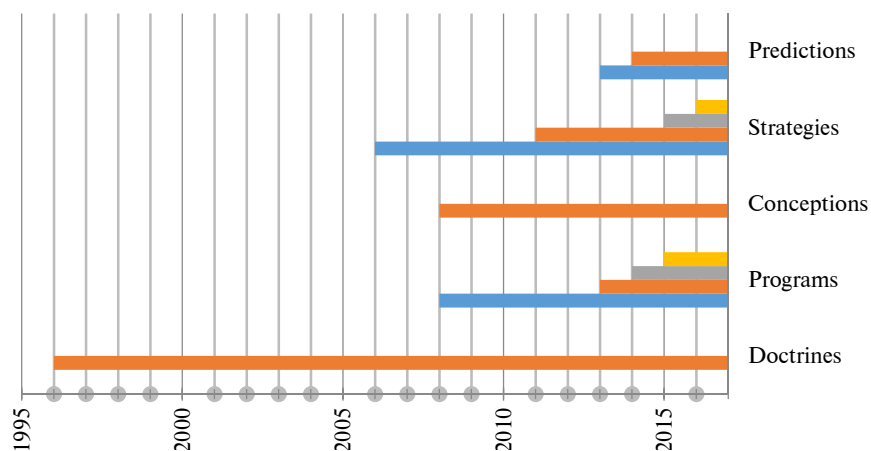

Fig. 1. Validity period of program documents

- State program «The development of industry and increase its competitiveness»;
- Federal Target Program «World Ocean» in 2016-2031

1.3. concepts

- The concept of long-term social and economic development of the Russian Federation for the period until 2020

1.4. strategies

- Strategy of scientific and innovative development in the Russian Federation for the period until 2015;
- Russian innovative development strategy for the period up to 2020;
- «On National Security Strategy»;
- Strategy of scientific and technological development of the Russian Federation until 2035

1.5. predictions

- Prediction of long-term social and economic development of the Russian Federation for the period until 2030;
- Prediction of scientific and technological development of the Russian Federation for the period until 2030

1.6. strategies for the key industries (13 strategies).

The vector of innovative and industrial policy is assigned by the government. The readiness of the government and business structures to move in innovative direction determines the success of this politics in large measure. Numerous federal level documents attempt to revive innovative activity and increase the performance efficiency of the Russian companies through enhanced funding support of research and developments, but despite all of this, a substantial lag of the Russian Federation from the foreign competitors, world's technical leaders, still remains. The results of the development strategy of science and innovations in the Russian Federation for the period up to 2015 show its elaboration and realization levels [16]. The key figures of scientific and innovative development up to 2015 are defined in this document. However, around 50–60 % of the main indicators have not been not achieved and some indicators have negative dynamics. The aims of this strategy are not implemented and it is proven by its duplication in the Strategy of innovative development in the Russian Federation for the period up to 2020 [14]. It is

important to note that in accordance with Strategy 2020 a slight increase of the Russian share in the world markets of high-technology products (2 %) is planned by 2020. It is contrary to the main aim of Strategy 2020, which is to transfer the economy of our country to a predominantly innovative way of development. Nowadays, the sales level of high-technological and science-intensive products of Russian industrial companies is not comparable with the present sales level of the world's leaders. In 2015, the sales level of the Russian automobile manufacturer AvtoVAZ totaled 352 thousand items or 176 billion rubles, the number of employees was 43,000 people, whereas the sales level of the German multinational automotive manufacturing company Volkswagen Group totaled 193 billion euros with the total number of employees amounting to 550,000 people back in 2012. Thus, the gap in sales level between the Russian company and its foreign competitor is more than 66 times (1€ = 61₽). This is an illustrative example because it indicates the magnitude of productive activity which is necessary for competitive innovative policy. Furthermore, it is necessary to have access to global markets for successful realization of extensive innovations. In case this opportunity is absent, investments in innovations could be not only ineffective but also unprofitable because of an extended payback period.

In view of the current social, economic and political conditions, the strategy of innovative development of Russian industry should be closely linked to the opportunity to enter specific markets which are the most favorable for Russian business. In today's world the process of admission to global markets is determined by the position of the United States as the leading economic power in the world. The share of this country accounts for a little less than 40 % of the world's market and 80 % of payments in the world is in US dollars [17].

The strategy of scientific and technological development of the Russian Federation until 2035 is aimed at increasing production, and the scientific and technological potential of our country [15]. This document has been developed based on the disadvantages of Strategy 2020. The list of scientific and technological priorities has been revised and only the areas with the highest probability of success have been highlighted. The

decision was necessary in the conditions of the available resources which are limited. There is a clear link between the spending level on Research and Development (R&D) and the organization's competitiveness. According to the latest UNESCO Science «Towards 2030» report, public spending on science is increasing every year, both in absolute and in relative terms [26]. In the period from 2007 to 2013, Global R&D intensity in the world increased from 1.57 % to 1.70 % of gross domestic product (GDP). However, there are natural limits to funding. There is no country that can provide the commercialization of all results obtained through research and development in the form of a final product. The significant point of strategy of scientific and technological development of the Russian Federation is the recognition of the importance of fundamental science as funding of basic research in the recent years had a downward trend [4].

2. general legal acts (Fig. 2):

2.1. Constitution of the Russian Federation (RF);

2.2. RF Civil Code;

2.3. RF Budget Code;

2.4. RF Tax Code;

2.5. Federal Law «On Science and State Scientific and Technical Policy»;

2.6. Federal Law «On Security»;

2.7. Federal Law «On the strategic planning in the Russian Federation»;

2.8. Federal Law «On Industrial Policy in the Russian Federation».

There is a significant point concerning the import substitution issue in the Federal Law №

488-FL «On Industrial Policy in the Russian Federation» [12]. The paramount idea is to provide the extremely high level of economic and technological self-sufficiency and industrial manufacturing. In order to implement the forced import substitution policy, it is necessary to be committed to the following principle: to present on the international market the national production that is more effective than foreign equivalents. If import is cheaper and more effective than domestic production, it is necessary to buy such products and technologies abroad. The above-mentioned statement has a logical explanation: if Russia spends time investigating things already researched, the lag from world leaders will become too colossal to eliminate. Besides, an unsuccessful import substitution policy may be the cause of ineffective resource management and an increasing backlog with respect to world leaders. In case of prosperous technology and product implementation it will be necessary to bring it to the global market for a payback, where these products will face more advanced equivalents [3]. To sum up, indiscriminate import substitution can lead to severe negative consequences.

3. legal acts in the sphere of innovative activity stimulation and promotion (Fig. 3):

3.1. RF Government Decree «On the complex of measures on development and government support of small enterprises in the sphere of material production and the promotion of their innovative activities»;

3.2. Federal Law «On Special Economic Zones in the Russian Federation»;

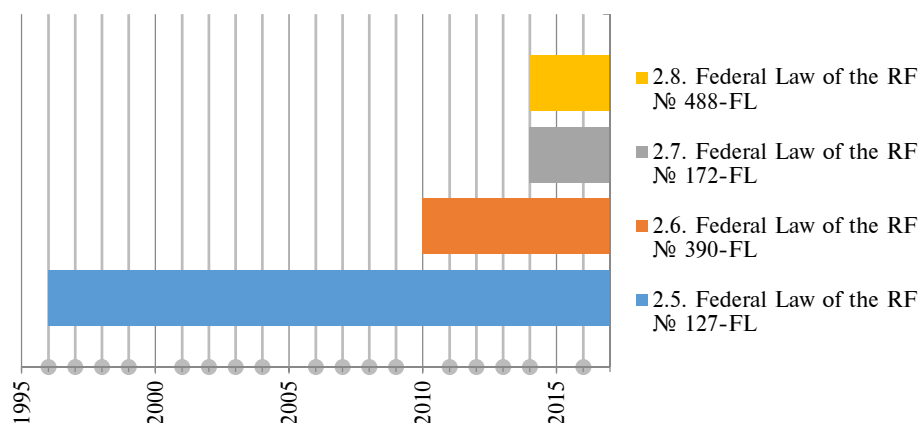

Fig. 2 Validity period of the general legal acts

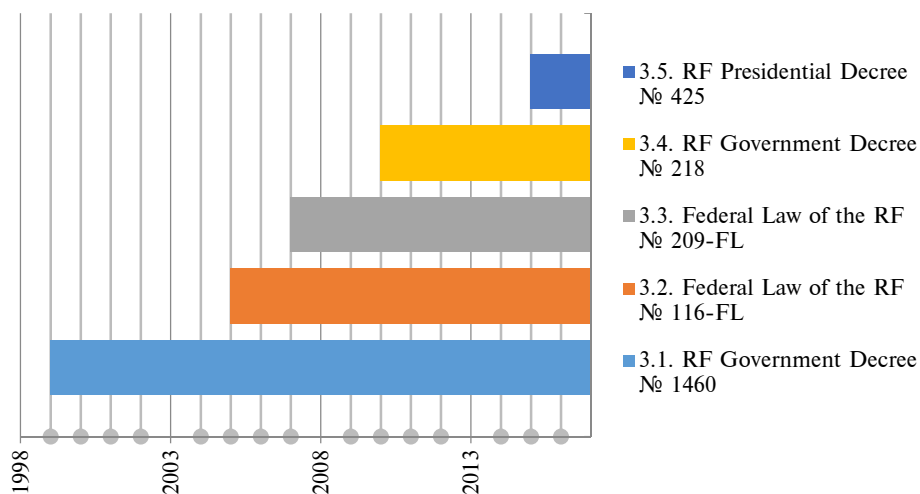

Fig. 3. Validity period of legal acts in the sphere of stimulating and promoting innovative activity

3.3. Federal Law «On the development of small and medium enterprises in the Russian Federation» (article 22. Support for medium and small-sized business in the sphere of innovations and industrial production);

3.4. RF Government Decree «On state support measures of cooperation development of Russian educational institutions of higher education, public research institutions and organizations implementing integrated projects for high-technological production, within the sub-program «Institutional development of the research sector» state program of the Russian Federation «Development of science and technology» for 2013–2020;

3.5. RF Presidential Decree «On amendments in RF Presidential Decree of February 13, 2012 № 181 «On the establishment of the Russian President scholarships for young scientists and post-graduate students engaged in advanced research and development in priority areas of the Russian economy modernization» and the revocation of some acts of the President of the Russian Federation».

At the present time potential realization of medium and small-sized business is becoming more relevant. Entrepreneurship is one of the key factors of Russian economic development and gives an opportunity to solve numerous important social and economic tasks: competition growth, employment creation, increase in tax revenue and others. In the application of economic sanctions against the Russian Federation, special attention

should be paid to creating conditions for credit institutions to enhance lending for medium and small-sized business. The main problem is increasing the financial capabilities which are necessary for implementation of innovative projects and programs [1]. This aspect is not reflected in article 22 of the Federal Law of July 24, 2007 №209-FL «On the development of small and medium enterprises in the Russian Federation» [13]. The significant disadvantage of this document is that in describing support measures for subjects of medium and small-sized business in the sphere of innovations and industrial constructions, the word «may» is used when regarding public authorities and self-governing authorities acts. This means there is no direct duty to realize the listed acts in the mentioned document form, which calls into question the general effectiveness of the government policy in the sphere of innovative activity stimulation.

4. legal acts in the sphere of intellectual property (IP) (Fig. 4):

4.1. RF Civil Code (part 2 – Federal Law № 14-FL dated 26.01.1996; part 4 – Federal Law № 230-FL dated 18.12.2006);

4.2. Federal Law «On Commercial Secrets»;

4.3. RF Government Decree «On the Governmental Commission for combating violations of intellectual property, its legal protection and usage»;

4.4. RF Government Decree «On the procedure for disposal of the rights to the results of scientific and technical activity»;

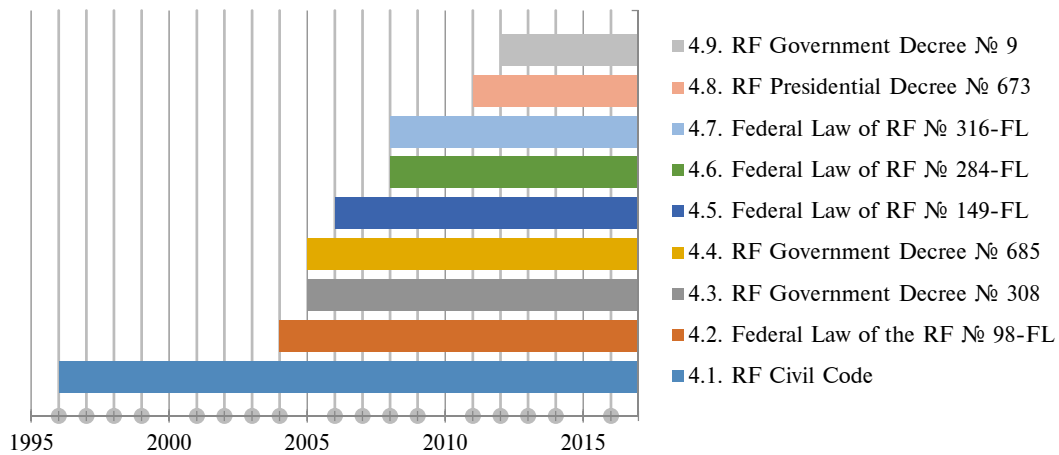

Fig. 4. Validity period of legal acts in the sphere of IP

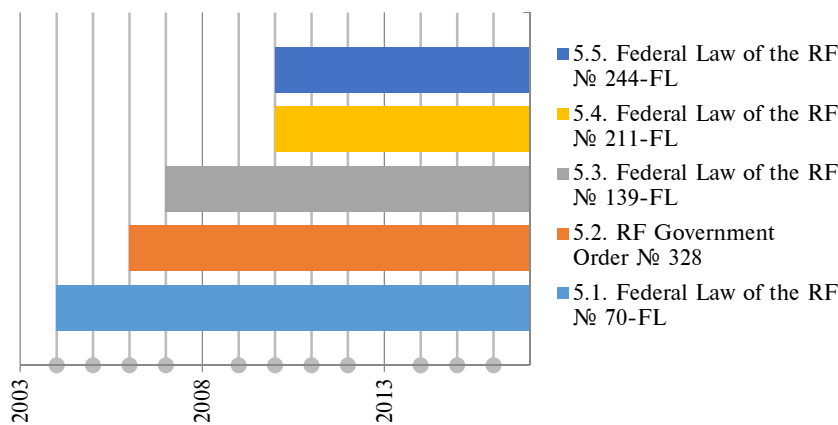

Fig. 5. Validity period of legal acts in the sphere of innovative infrastructure

4.5. Federal Law «On information, information technologies and protection of information»;

4.6. Federal Law «On the transfer of rights to uniform technology»;

4.7. Federal Law «On patent attorneys»;

4.8. RF Presidential Decree «On the Federal Service for Intellectual Property»;

4.9. RF Government Decree «On the implementation of control and supervision in the sphere of legal protection and usage of results of civil intellectual activity, created by federal budget allocations, and also control and supervision in the established sphere of activities in relation to government customers and organizations – executors of government contracts relating to research, development and engineering works».

A perception of the IP role in the development of innovative economy leads to the improvement of the legislation in the sphere of its protection and

usage [25]. Changes made by the legislation in Part Four of the RF Civil Code are aimed at promoting innovative processes by transfer simplification of the intellectual activity results and ensuring more reliable protection of IP rights (section VII, chapter 69, article 1227, 1229, 1232, 1233, 1234, 1236 of the RF Civil Code) [10]. However, at the moment of the government's attempts to increase the role of IP in the innovative activity of organizations and country have not achieved the intended effect. There are the following problems:

1) incomprehension of the economic essence of IP by subjects of the innovative process [18];

2) gaps in the legal regulation of scientific and technological activity and IP (an unsatisfactory level of IP protection);

3) ineffective usage of the results of intellectual activity [20].

5. legal acts in the sphere of innovative infrastructure (Fig. 5):

5.1. Federal Law «On the Status of science town of the Russian Federation»;

5.2. State program «Creation of the Russian high-tech industrial parks in the area»;

5.3. Federal Law «On the Russian Corporation of Nanotechnologies»;

5.4. Federal Law «On the reorganization of the Russian Corporation of Nanotechnologies»;

5.5. Federal Law «On Innovation «Skolkovo center».

The main regulatory acts of federal level which regulate the creation and development of innovative infrastructure are presented in Fig. 5. Intense formation of the infrastructure sector is also declared in the program documents for the entire country as well as for individual subjects of innovative activity. Having analyzed the process of creating the national infrastructure since the 1990s it is possible to identify a number of factors that hinder the success of the infrastructure sector. Among the key factors are:

- 1) absence of institutional integrity with the higher education institution;
- 2) low level of consistency in the activity of infrastructure organizations;
- 3) absence of motivation to participate in research projects for young professionals;
- 4) deficit of funding.

As a result, the lack of interaction between science and business remains. The observed increase in the number of infrastructure organizations will not contribute to achieving the goals as long as the above-mentioned conditions are ignored.

Due to space limitations, it is impossible to consider in detail the existing regulatory basis in the sphere of industry and innovations. According to this analytical review of the key documents, it could be concluded that the main disadvantage of all program and strategic documents in the sphere of science development is the formation of false criteria for assessing the efficiency of interventions. It is proposed to estimate the global level of research and development on the basis of publication activity, global competitiveness based on international ratings, the effectiveness of the organizations' R&D performance based on the public results presentation. The most important and objective criterion of scientific and technological leadership of a country that is an increase in sales of high-technological and science-intensive products of Russian companies of the real economy is completely ignored.

Having examined the issue of practical realization of regulatory documents in the sphere of industry, science and innovations, it is necessary to consider directions and prospects of Russian economic development. For a long period, economic growth was provided by the raw materials industry. Investments in innovations were not of economic benefit and ineffective for government and business because of super-high profitability of the oil and gas sector [27]. Under current conditions there is no question that the transition to innovation-oriented style of development must be made. Continued development in the conservative way means total loss of technological sovereignty and jeopardizes the country's defense capability [19]. In this case, there is no need to revise the current policy and apply special actions.

It is necessary to define clearly the goal in the transition to an innovative way: Russia's inclusion into the number of countries that are technological leaders. The following tasks of prime importance have to be solved:

- 1) achieving technological independence from external forces in the military sphere;
- 2) overcoming the backlog of Russian production technologies from similar foreign ones (this task need to be implemented by following the principle of reasonable import substitution which is indicated above);
- 3) creating original breakthrough technologies on the basis of scientific research results that have no counterparts abroad (with the formation of new markets for science-intensive products).

It is necessary to develop international cooperation in the sphere of science, technology and innovations guided by the principle of equal participation in international projects for the successful innovative policy in Russia. In accordance with the specifics of the current situation, it is not possible to solve these problems independently due to the limited resource base as well as the lack of required knowledge, skills and competencies [24].

Conclusions. The analytical review of the current regulatory basis in the sphere of science, industry and innovations allowed the authors to identify some challenges and barriers to the industrial growth of the Russian economy.

1. One of the key problems is the presence of a deep disconnect between the current research

capacity and low demand for it. This resource is important for both internal economic development and for access to global markets. However, it is not used properly. The current situation requires to reconsider the industrial policy and to determine the government's role in involving scientific research results in the economic turnover. It is necessary to create the specific mechanism that promotes effective commercialization of innovations.

2. When Russia implements a policy of import substitution, it should avoid economic isolation and follow the principles of reasonable import. Indiscriminate import substitution is the reason for reduction in production efficiency: productivity, growth rates and others. However, it is necessary to provide a high level of technological independence of key industries despite the economic benefits of international division of labor. In order to execute this task successfully, industrial policy should provide for the establishment of privileged conditions for the development of specific industries. It will promote to the progressive breakthrough development of the national economy by the creation of «growth points».

3. According to the official statistical data, the intensity of processes in organizations implementing technological innovations remains low (the percentage of organizations is 9.8 % in 2015). Despite the implementation of various support programs for small and medium-sized business in the sphere of innovations and industrial production, the innovative activity of small industrial enterprises has a tendency to reduction (in 2015 the indicator value decreased to 4.5 %). The need to increase innovative activity of Russian organizations can be satisfied by the combination of legal, direct and indirect methods of stimulation in terms of unified state policy. The main tool of direct regulation is the support in the form of public and private partnerships. On the one hand, the control over the fulfillment of industrial processes is being

strengthened; on the other hand, the conditions for the commercialization of scientific results are being improved. As a rule, the effect of indirect support measures is carried out due to the fiscal mechanism. It is necessary to consider some ways of decreasing the tax burden on business and also to find opportunities to modernize the system of tax administration.

4. The important point is amending the current regulatory basis regarding the choice of forms and methods of government support for innovative activity in implementing the above-mentioned approaches which promote the shift towards the innovative way of development. The lack of the necessary results leads to a constant replacement of some support forms by others by the legislator. However, these forms are also becoming ineffective after a while. The unsatisfactory situation is due to the choice of support forms and methods inappropriate and inadequate in the current realities of Russian transition economy. A special focus should be paid to forming the program-targeted approach in the organization of innovative strategy. This approach is aimed at setting certain goals, challenges, timeframes for implementation; strengthening the executors who are responsible for results concerning a specific project. As practice shows, as such an approach is absent, a large number of documents are declarative and do not contain specific measures aimed at providing social and economic development stability and a high level of Russian national security.

Directions for further research are seen in the development of the industrial policy of an enterprise in modern political and economic conditions. The need for changes in the development strategy in modern enterprises is caused not only by escalating competition, but also by the ability to influence the economic situation in the country as one of the most important participants in the process of forming state industrial policy.

REFERENCES

[1] A.S. Alisenov, Nalogovoe stimulirovanie innovatsii v ekonomike Rossii [Innovation Tax Credits in Russian economics]. Moscow, Prospekt, 2015. 128 p.

[2] E.S. Balashova, O.I. Gnezdilova, Problemy pravovogo regulirovaniya innovatsionnoi deyatel'nosti

v Rossii [Legal regulation problems of Russian innovative activities], Innovative science. Economy and economic sciences. 3-1 (15) (2016) 62–67.

[3] V.B. Betelin, O probleme importozameshcheniya i al'ternativnoi modeli ekonomicheskogo razvitiya Rossii

[About import substitution problem and alternative model of Russian economic development], *Strategicheskie priority (jelectronnyi mezhdunarodnyi nauchno-analiticheskii zhurnal)* [Strategic priorities]. 1 (9) (2016). URL: <http://sec.chgik.ru/wp-content/uploads/2016/05/SP-16-1.pdf> (accessed January 16, 2017).

[4] **V.V. Ivanov**, Nauchno-innovatsionnyi krizis i puti ego preodoleniya [Research and innovation crisis and ways of overcoming], *Innovatsii* [Innovations]. (11) (2015) 12–19.

[5] **A.I. Kotov**, Innovatsionnaya deyatel'nost' i predprinimatel'skaya sreda: vremya idet – protivorechiya ostaiutsya [Innovative activities and business environment: times marches on but contradictions are saved], *Innovatsii* [Innovations]. (4) (2012) 107–113.

[6] **E.A. Mazilov**, Osnovnye indikatory i faktory innovatsionnogo razvitiya promyshlennosti regiona [Basic indicators and innovative development factors of region's industry], *Menedzhment i biznes-administrirovanie* [Management and business administration], (1) (2013) 166–178.

[7] **V.N. Makoveev**, Zarubezhnyi opyt stanovleniya naukoemkikh proizvodstv [Foreign experience of formation of high-tech industries], *Vestnik CHGU* [CHGU Herald], 3 (50) (2013) 62–67.

[8] **I.A. Maksimtsev**, **A.E. Karlik**, **V.E. Rokhchin**, Stsenarii strategicheskogo razvitiya promyshlennosti rossiiskogo Severo-Zapada [Scenario of the strategic industrial development of the Russian North-West], *Economy and management*, (12) (2012) 6–12.

[9] **E.A. Mil'skaya**, Strategicheskoe upravlenie innovatsionno-aktivnym predpriyatiem [Strategic management of innovative active enterprise]. St. Petersburg, SPbGPU Publ., 2011. 295 p.

[10] **I.IU. Mirskikh**, **ZH.A. Mingaleva**, Pravovoe regulirovanie prav na rezul'taty intellektual'noi deyatel'nosti v Rossii i za rubezhom [Legal regulation of the rights of intellectual activity results in Russia and abroad], *Perm University Herald. Juridical sciences*, 3 (29) (2015) 62–69.

[11] **M.A. Nazarov**, **E.P. Fomin**, Problemy razvitiya innovatsionnoi infrastruktury v rossiiskoi ekonomike [Innovation infrastructure development problems in Russian economy]. *Economy and management. Economic sciences*, 4 (125) (2015) 38–43.

[12] RF Federal Law «About industrial policy in the Russian Federation» of December 31, 2014 № 488 FZ.

[13] RF Federal Law «About development of small and medium-sized businesses in the Russian Federation» of July 24, 2007 № 209 FZ.

Balashova E.S. E-mail: elenabalashova@mail.ru

Gnezdilova O.I. E-mail: gnezdilova-o.i@mail.ru

[14] Strategy of innovative development in the Russian Federation. December 8, 2011.

[15] Strategy of scientific and technological development in the Russian Federation. December 1, 2016.

[16] Strategy of science and innovation development in the Russian Federation. February 15, 2006.

[17] **A.G. Fonotov**, Strategiya-2035. Zhelaemoe. Vozmozhnoe. Dostizhimoe [Strategy-2035. Desirable. Possible. Achievable]. *Innovatsionnaya Rossiya* [Innovative Russia], (6) (2016) 24–31.

[18] **A. Shatov**, **E. Safargaleeva**, O roli intellektual'noi sobstvennosti v innovatsionnom razvitii strany [About intellectual property in innovative development of the country], *Ekonomika i upravlenie (jelectronnyi nauchno-prakticheskii zhurnal)* [Economy and management], (4) (2014). URL: http://www.bagsurb.ru/about/journal/scientific_seminars/SHATOV,%20SAFARGALEE%20VA.pdf (accessed January 16, 2017).

[19] **E.S. Balashova**, **E.A. Gromova**, Resource-based view as a perspective management model in Russian reality, *Problems and Perspectives in Management*, 14 (2) (2016) 325–330.

[20] **E.S. Balashova**, **V.V. Glukhov**, Operations strategies in info-communication companies, *Internet of Things, Smart Spaces, and Generation Networks and Systems* (2015) 562–566.

[21] **M. Colombo**, **L. Grilli**, **L. Piscitello**, **C. Rossi-Lamastra**, Science and Innovation Policy for the New Knowledge Economy. Cheltenham, Edward Elgar Pub., 2011. 208 p.

[22] **C. Freeman**, **L. Soete**, The economics of industrial innovation. Penguin, 1974. 409 p.

[23] **G. Mensch**, **Ramanujam Vasudevan**, Improving the Strategy-Innovation Link, *Journal of Product Innovation Management*, 2 (4) (1985) 213–223. DOI: 10.1111.1540-5885.240213/epdf

[24] **T.A. Meshkova**, **E.IA. Moiseichev**, Russia's experience of foresight implementation in global value chain research, *Journal of Innovation and Entrepreneurship* (2016). DOI: 10.1186/s13731-016-0039-7

[25] **Zh. Mingaleva**, **I. Mirskikh**, The protection of Intellectual property in educational process, *Procedia – Social and Behavioral Sciences* (2013) 1059–1062.

[26] UNESCO Science Report. Towards 2030. URL: <http://en.unesco.org/node/252168> (accessed December 20, 2016).

[27] **T.V. Yurieva**, Innovative social economy: formation and development in Russia. *Science prospects*, (12) (2011) 271–276.

СПИСОК ЛИТЕРАТУРЫ

[1] **Алисенов А.С.** Налоговое стимулирование инноваций в экономике России. М.: Проспект, 2015. 128 с.

[2] **Балашова Е.С., Гнездилова О.И.** Проблемы

правового регулирования инновационной деятельности в России // *Инновационная наука. Сер. «Экономика и экономические науки»*. 2016. № 3-1(15). С. 62–67.

- [3] **Бетелин В.Б.** О проблеме импортозамещения и альтернативной модели экономического развития России // *Стратегические приоритеты* (электронный международный научно-аналитический журнал). 2016. № 1(9). URL: <http://sec.chgik.ru/wp-content/uploads/2016/05/SP-16-1.pdf> (дата обращения: 16.01.2017).
- [4] **Иванов В.В.** Научно-инновационный кризис и пути его преодоления // *Инновации*. 2015. № 11. С. 12–19.
- [5] **Котов А.И.** Инновационная деятельность и предпринимательская среда: время идет – противоречия остаются // *Инновации*. 2012. № 4. С. 107–113.
- [6] **Мазилев Е.А.** Основные индикаторы и факторы инновационного развития промышленности региона // *Менеджмент и бизнес-администрирование*. 2013. № 1. С. 166–178.
- [7] **Маковеев В.Н.** Зарубежный опыт становления наукоемких производств // *Вестник ЧГУ*. 2013. № 3(50). С. 62–67.
- [8] **Максимцев И.А., Карлик А.Е., Рохчин В.Е.** Сценарий стратегического развития промышленности российского Северо-Запада // *Экономика и управление*. 2012. № 12. С. 6–12.
- [9] **Мильская Е.А.** Стратегическое управление инновационно-активным предприятием. СПб.: СПбГПУ, 2011. 295 с.
- [10] **Мирских И.Ю., Мингалева Ж.А.** Правовое регулирование прав на результаты интеллектуальной деятельности в России и за рубежом // *Вестник Пермского университета. Сер. «Юридические науки»*. 2015. № 3(29). С. 62–69.
- [11] **Назаров М.А., Фомин Е.П.** Проблемы развития инновационной инфраструктуры в российской экономике // *Экономика и управление. Сер. «Экономические науки»*. 2015. № 4(125). С. 38–43.
- [12] О промышленной политике в Российской Федерации: Федер. закон РФ № 488-ФЗ от 31.12.2014 г. Доступ из справ.-правовой системы «КонсультантПлюс».
- [13] О развитии малого и среднего предпринимательства в РФ: Федер. закон РФ № 209-ФЗ от 24.07.2007 г. // СПС Консультант Плюс.
- [14] Стратегия инновационного развития РФ на период до 2020 года: Распоряж. Правительства РФ № 2227-р от 08.12.2011 г. // СПС Консультант Плюс.
- [15] Стратегия научно-технологического развития РФ до 2035 года. URL: <http://static.krem>
- [16] Стратегия развития науки и инноваций в РФ на период до 2015 года: Протокол № 1 от 15.02.2006 г. [Электронный ресурс]. Доступ из справ.-правовой системы «КонсультантПлюс».
- [17] **Фонотов А.Г.** Стратегия-2035. Желаемое. Возможное. Достижимое // *Инновационная Россия*. 2016. № 6 (212). С. 24–31.
- [18] **Шатов А., Сафаргалеева Е.** О роли интеллектуальной собственности в инновационном развитии страны // *Экономика и управление (электронный научно-практический журнал)*. 2014. № 4. URL: http://www.bagsurb.ru/about/journal/scientific_seminars/SHATOV,%20SAFARGALEEVA.pdf (дата обращения: 16.01.2017).
- [19] **Balashova E.S., Gromova E.A.** Resource-based view as a perspective management model in Russian reality // *Problems and Perspectives in Management*. 2016. No. 14(2). Pp. 325–330.
- [20] **Balashova E.S., Glukhov V.V.** Operations strategies in info-communication companies // *Internet of Things, Smart Spaces, and Generation Networks and Systems*. 2015. Pp. 562–566.
- [21] **Colombo M., Grilli L., Piscitello L., Rossi-Lamastra C.** Science and Innovation Policy for the New Knowledge Economy. Cheltenham, Edward Elgar Pub., 2011. 208 p.
- [22] **Freeman C., Soete L.** The economics of industrial innovation. Penguin, 1974. 409 p.
- [23] **Mensch G., Vasudevan Ramanujam.** Improving the Strategy-Innovation Link // *Journal of Product Innovation Management*. 1985. No. 2(4). Pp. 213–223. DOI: 10.1111.1540-5885.240213/epdf
- [24] **Meshkova T.A., Moiseichev E.IA.** Russia's experience of foresight implementation in global value chain research // *Journal of Innovation and Entrepreneurship*. 2016. DOI: 10.1186/s13731-016-0039-7.
- [25] **Mingaleva Zh., Mirskikh I.** The protection of Intellectual property in educational process // *Procedia – Social and Behavioral Sciences*. 2013. Pp. 1059–1062.
- [26] UNESCO Science Report. Towards 2030. URL: <http://en.unesco.org/node/252168> (дата обращения: 20.12.2016).
- [27] **Yurieva T.V.** Innovative social economy: formation and development in Russia // *Science prospects*. 2011. No. 12. Pp. 271–276.

Балашова Е.С. E-mail: elenabalashova@mail.ru

Гнездилова О.И. E-mail: gnezdilova-o.i@mail.ru

Статья поступила в редакцию 07.03.17

DOI: 10.18721/JE.10204
UDC 338.2

ANALYSIS AND EVALUATION OF INNOVATION AND INVESTMENT ACTIVITIES POTENTIAL OF ECONOMIC ENTITIES (FOR EXAMPLE, THE NORTHWESTERN FEDERAL DISTRICT)

E.A. Mil'skaya, A.V. Bychkova

Peter the Great Saint-Petersburg Polytechnic University, St. Petersburg, Russian Federation

The current situation of the economic entities of the Northwestern Federal District (NWFD) has been analyzed in this article. Regional innovative activity evaluation is an actual topic of studies among Russian economic scientists, research centers and departments. The current innovation and investment situation in Northwestern Federal district has been characterized and statistical data for the period of 2005–2014 was analyzed by authors. The result of this work concludes the uneven distribution of innovative activity among economic actors that are members of the Federal district. Due to the significant role of the government in the formation of investment activity in the regions, an analysis was conducted of the directions of industrial policy of innovative-investment activity of economic entities. The results of the study showed that nowadays in each subject of the Northwestern Federal District there are a lot of actions that are made to strengthen innovation activities, developed plans and strategies for its development. Moreover, authors carry out evaluation of existing methods for the analysis of innovative activity and innovative potential of the region. In total number, nine methods developed by Russian institutions, organizations and scientists were reviewed there. Using this information, the comparative analysis of all methods was released; the advantages and disadvantages of each were mentioned. Based on this, authors have selected only one methodology and used it in further calculations. The authors have performed analysis of innovative-investment activity of economic entities in the Northwestern Federal District, as well as the evaluation of innovative potential of each actor of the region. The results showed that in most regions of the northwestern Federal District it is necessary to strengthen government's actions in order to stimulate innovative activity at the enterprises. The final part of the work authors have made a forecast of the volume of innovative goods, works and services, produced by enterprises of the Federal District. The linear regression equation was used to build a forecast for 2015–2025. The results of the study can be used for the formation of the policy for further regional development, creation of innovation and investment strategy and development of the actors and the region in general.

Keywords: the Northwestern Federal District; innovation; investment and innovative activity; regression analysis; measures of state support; correlation analysis; economic entity of the region

Citation: E.A. Mil'skaya, A.V. Bychkova, Analysis and evaluation of innovation and investment activities potential of economic entities (for example, the Northwestern federal district), St. Petersburg State Polytechnical University Journal. Economics, 10 (2) (2017) 44–53. DOI: 10.18721/JE.10204

АНАЛИЗ И ОЦЕНКА ПОТЕНЦИАЛА ИННОВАЦИОННО-ИНВЕСТИЦИОННОЙ ДЕЯТЕЛЬНОСТИ ЭКОНОМИЧЕСКИХ СУБЪЕКТОВ (НА ПРИМЕРЕ СЕВЕРО-ЗАПАДНОГО ФЕДЕРАЛЬНОГО ОКРУГА)

Е.А. Мильская, А.В. Бычкова

Санкт-Петербургский политехнический университет Петра Великого,
Санкт-Петербург, Российская Федерация

Анализируется состояние экономических субъектов Северо-Западного федерального округа (СЗФО). Оценка инновационной активности регионов является актуальной темой исследования среди российских ученых-экономистов, исследова-

тельских центров и ведомств. Северо-Западный федеральный округ охарактеризован с точки зрения текущей инновационной и инвестиционной ситуации, проанализированы статистические данные за 2005–2014 гг. Сделаны выводы о неравномерности распределения инновационной активности среди экономических субъектов, входящих в состав федерального округа. Так как роль государства очень велика при формировании инвестиционной деятельности в регионе, проведен анализ направлений промышленной политики в области инновационно-инвестиционной деятельности экономических субъектов. Результаты исследования показали, что на сегодня в каждом субъекте СЗФО проводятся меры по усилению инновационной деятельности, разработаны планы и стратегии их развития. Осуществлена оценка существующих методов анализа инновационной активности и инновационного потенциала региона в целом. Рассмотрено девять методик, разработанных российскими институтами, организациями и учеными. С использованием полученной информации, проведена сравнительная характеристика всех методов, выделены преимущества и недостатки каждого. На основе проведенного анализа методологий выбрана одна, которая и использовалась при дальнейших расчетах. Выполнен анализ инновационно-инвестиционной активности экономических субъектов СЗФО, а также проведена оценка инновационного потенциала каждого субъекта региона. Результаты показали, что в большинстве регионов СЗФО необходимо усилить меры государственного стимулирования инновационной деятельности на предприятиях. Заключительный этап исследования – построение прогноза объема инновационных товаров, работ и услуг, производимых предприятиями федерального округа. С использованием уравнения линейной регрессии построен прогноз на 2015–2025 гг. Результаты исследования могут применяться при формировании политики дальнейшего развития регионов, разработке стратегии инновационного и инвестиционного развития СЗФО и субъектов.

Ключевые слова: Северо-Западный федеральный округ; инновационная деятельность; инвестиционно-инновационная активность; регрессионный анализ; меры государственной поддержки; корреляционный анализ; экономический субъект региона

Ссылка при цитировании: Мильская Е.А., Бычкова А.В. Анализ и оценка потенциала инновационно-инвестиционной деятельности экономических субъектов (на примере Северо-Западного федерального округа) // Научно-технические ведомости СПбГПУ. Экономические науки. 2017. Т. 10. № 2. С. 44–53. DOI: 10.18721/JE.10204

Introduction. In the modern world, the problem of innovative development of the regions is particularly urgent. Regional economic entities now need to spend more and more efforts to carry out scientific activities, conduct research and development in order to be competitive and confidently cope with the instability of the economic and political situation in the country.

The importance of the study is due to the need to develop innovative and investment activities in all economic entities of the Russian Federation, to create a favorable innovation and investment climate, to increase the competitiveness of regional economic entities and their attractiveness for both Russian and foreign investors.

The subject of research in this article are the economic entities of the Northwestern Federal District, one of the most developed and attractive regions in terms of innovation. Economic entities of the region are not chosen by chance, since statistical information on them will be regarded in this work as a set of innovative activities of enterprises operating in that territory.

Purpose of the study. The purpose of this work is to assess the innovative potential of the economic entities in the Northwestern Federal District and to build a forecast of their innovative activity for the coming years, as well as to develop recommendations for improving the efficiency of innovation and investment activities of the entire Northwestern Federal District.

To achieve this goal, it is necessary to carry out an analysis of innovation and investment activities of the region as a whole, based on the chosen methodology, to assess its development potential on the basis of an analysis of the activities of economic entities in the region and to build a forecast of the volume of innovative goods, works and services for the coming years.

Speaking about industrial manufacturers, in particular, it should be noted that they are primarily focused on long-term, sustainable development of their enterprises, on the growth of production volumes based on innovations, on increasing their investments in R&D [7,

14]. Unfortunately, it should be noted that in 2014 the share of organizations in the regions under investigation implementing technological, organizational, marketing innovations declined compared to the period of 2011–2013. In 2011, 10.4 % of enterprises carried out innovative activities, while in 2014 only 9.4 % did so. At the same time, innovations in R&D are growing from year to year: 29.8 % of innovative enterprises made investments specifically in research and development in 2011, while in 2014 they amounted to 33.3 % [3]. Since 2015, the process has slowed down due to the next wave of crisis. The sanctions imposed by the West have also had their negative effect.

The Northwestern Federal District includes 10 federal subjects: the Republic of Komi, the Republic of Karelia, Arkhangelsk, Vologda, Kaliningrad, Leningrad, Murmansk, Novgorod, Pskov regions and the city of St. Petersburg. Until 2012 the Northwestern Federal District increased the number of advanced production technologies in general, but almost all of them (more than 76 %) were created only in one entity, the city of St. Petersburg [15]. In recent years, there has been a trend towards slower growth in investment in capital assets. More than 37 % of the region's investments are concentrated in the same economic entity, St. Petersburg. Besides that, 15.28 % is concentrated in the Komi Republic and 13.2 % in the Leningrad Region. Actually, these subjects concentrate the greatest amount of investment [15]. In the Northwestern Federal District, attracted funds are the prevalent sources of investment financing. Only two subjects of the region: Pskov and Leningrad regions invest at their own expense. The unstable economic and political situation in the country had an impact on the inflow of foreign direct investment in the Northwestern Federal District, which was reflected in the negative balance of payments in the investment section [15].

According to statistical data, the greatest percentage of innovations is concentrated in technologies [15]. Most technological innovations are carried out in the production of electrical equipment, electronic and optical equipment (27 % in 2014), production of coke and petroleum products (23 %) and chemical production (21.4 %).

Research methodology. In order to evaluate the investment and innovation activity of the subjects of the studied region, various methods for evaluating the innovation activity of the subjects of the regions were analyzed, both devised by various authors and proposed by scientific centers and institutes. In particular, the methodology of the HSE, Financial University, AIIR, NISP, CRS «Northwestern», Erokhina [6], Pogodina [12], Bystritsky [4], Dubinin [5]. Each of the studied methods has both advantages and disadvantages in comparison with others. Some of the techniques analyze the factors that influence the development of innovative activity, others focus on the results.

As a result, from our point of view, the method of integrated rating analysis developed by Dubinin is the most appropriate one for evaluating the innovation activity of the region's subjects. The resulting indicator is «The volume of innovative goods, works and services», because it reflects the final result of innovation activities of enterprises, as well as the effectiveness of public policy. The main advantage of this method is that all key indicators that affect the innovative activity of functioning entities are considered in the analysis, and the influence of each indicator on innovation activity is taken into account. Through the study, we have decided to supplement this methodology with several other indicators that are relevant for the present time period:

- the costs of technical innovation;
- the share of the faculty in the total number of employed workers in the region;
- used advanced production technologies;
- use of the Internet at enterprises and organizations;
- the share of organizations engaged in research and development, for the region as a whole.

Results. As a result of the calculations, a correlation coefficient was obtained, which characterizes the degree of connection between the characteristic factors and the result factor (Tab. 2).

The next stage of the analysis is the grouping of indicators (Tab. 3) and the definition of an intermediate integral estimate. At the final stage of the analysis, a comprehensive assessment of the region's innovation activity (Tab. 4) is shown.

Table 1

Comparative characteristics of methods for assessing innovation activity

Author	Number of indexes	Sections	Advantages	Disadvantages
HSE	37	1 – Socio-economic conditions of innovation; 2 – Scientific and technical potential of the region; 3 – Innovation in the region; 4 – The quality of innovation policy.	Complex analysis; A low regional estimate for one indicator can be balanced by a high estimate for the other	A complex multi-level evaluation system
Financial University	180	1 – Level of socio-economic and financial development; 2 – Competitiveness and investment attractiveness; 3 – The level of scientific and technical potential; 4 – Level of development of innovation activities.	Broad coverage of indicators affecting the development of innovation in the region	The complexity of collecting statistical information, the inaccessibility of certain types of data
AIRP	23	1 – Research and development; 2 – Innovative activity; 3 – Socio-economic conditions.	It relies on the accumulated domestic and foreign experience of research, takes into account the opinion of experts and the position of federal authorities	Due to the use of the expert method of assessment, there may be a subjective opinion, obtaining inaccurate results
CSR «North-western»	15	1 – Preparation of human capital; 2 – Creation of new knowledge; 3 – Transmission and application of knowledge; 4 – Conclusion of innovative products on the market.	Broad coverage of indicators	The information environment is not evaluated
V.K. Zausaev, S.P. Bystritsky	15	1 – Macroeconomic; 2 – Infrastructural; 3 – Legal; 4 – Staffing; 5 – Economic.	Relative simplicity of calculations, availability of statistical data	To assess the state of the innovation environment, the use of fixed capital and information and communication technologies
A.S. Dubinin	13	1 – Economic development of the region; 2 – Innovation potential of industrial production; 3 – Scientific potential; 4 – Participation of the region in international technological exchange; 5 – Information and communication potential.	It covers all key indicators, takes into account the impact of each specific indicator on the innovation activity of the region	The resulting analysis factor is chosen by the expert, which may not accurately reflect the actual innovation activity in the region

Table 2

**The results of the correlation analysis
(the resultant characteristic is the volume of innovative goods, works and services)**

№	Characteristic factor	Correlation Ratio
1	The number of intellectual property objects created per 10,000 employees in the region's economy	0.9455049
2	Costs of technological innovation	0.9437164
3	The cost of R&D in the amount of 10,000 people in the economy of the region	0.9416247
4	The share of organizations using information and communication technologies in the total number of organizations in the region	0.9352655
5	GRP per capita of the region	0.9156026
6	Export of technologies and services of a technical nature	0.9080731

Continuation of Table 2

№	Characteristic factor	Correlation Ratio
7	Number of personal computers per 100 workers in the region	0.8929995
8	The proportion of faculty in the total number of employed region	0.8923734
9	Volume of investments in fixed capital per capita	0.8304422
10	Import of technologies and services of a technical nature	0.8274741
11	Used advanced production technologies	0.8197648
12	Number of scientific organizations per 10 thousand people employed in the economy	0.8013259
13	The ratio of the number of postgraduates and doctoral students to the total number of employed in the economy	0.7723728
14	Using the Internet in Organizations	0.7665354
15	The share of innovative-active enterprises in the total number of enterprises in the region	0.6635596
16	The proportion of staff engaged in research and development in the total number of employed in the economy of the region	0.6628784
17	The share of organizations engaged in research and development in the total number of enterprises in the region	0.4329411
18	The ratio of the number of candidates and doctors of science to the total number of employed in the economy	0.1492624

Table 3

Grouping of characteristic factors

Metric group		Indicators
Economic development of the region	ED	5, 9
Innovation potential of industrial production	IP	1, 11, 15
Scientific potential	SP	2, 3, 8, 12, 13, 16, 17, 18
Participation of the region in international technological exchange	TE	6, 10
IT potential	ITP	4, 7, 14

Table 4

Integral indicator of innovation activity of economic entities in the Northwestern Federal District, 2014

Subject	EP	IP	SP	TE	ITP	IRD
NWFD	0.8730	0.8096	0.7234	0.8678	0.8649	0.8257
Republic of Karelia	0.2857	0.1561	0.3945	0.2486	0.3874	0.2791
Komi Republic	0.4742	0.6090	0.5361	0.3903	0.5581	0.5077
Arhangelsk Oblast	0.3109	0.1945	0.3974	0.4044	0.2064	0.2887
Vologda Oblast	0.3797	0.5466	0.4065	0.7011	0.6180	0.5159
Kaliningrad Oblast	0.8266	0.7489	0.7960	0.5438	0.8349	0.7412
Leningrad Oblast	0.4574	0.4275	0.3744	0.3071	0.6217	0.4257
Murmansk Oblast	0.6266	0.3846	0.5306	0.5722	0.6704	0.5472
Novgorod Oblast	0.3856	0.1755	0.2054	0.0331	0.2241	0.1600
Pskov Oblast	0.4313	0.4537	0.2531	0.1295	0.0467	0.1974
Saint Petersburg	0.8983	0.8282	0.7395	0.8729	0.8596	0.8378

As it can be seen from the results of the study, St. Petersburg is the undoubted leader in terms of innovation activity: the value of the integral indicator is 0.8378, which exceeds the value of the indicator throughout the Northwestern Federal District. Quite good indicators also have been obtained in the Kaliningrad Oblast (0.7412). Murmansk and Vologda regions and the Republic of Komi have an average level of innovative activity. Novgorod and Pskov regions have the lowest indicators.

Further, the innovative potential of the region's subjects is directly assessed and the forecast is calculated for 10 years. To determine the innovative potential of the Northwestern Federal District, a methodology based on the calculation of an integrated indicator evaluating the innovation potential in terms of its formation can be used [10].

As a result of the calculations, it turned out that St. Petersburg has the highest value of the innovation capacity assessment indicator; in addition, for the entire study period it has been growing from 2.050 to 2.156 conventional units. The Vologda, Pskov and Arkhangelsk regions have the lowest estimates of the innovative potential. Despite the lowest value of the indicator, the Pskov Oblast showed a significant increase by 0.263 conventional units (Tab. 5)

Table 5

The value of the integral indicator of the assessment of innovative potential of economic entities and the Northwestern Federal District, conventional units

Region	2005	2010	2011	2012	2013	2014
NWFD	1.047	1.065	1.069	1.106	1.103	1.112
The Republic of Karelia	0.857	0.902	0.880	0.869	0.892	0.919
Komi Republic	0.935	0.961	1.011	1.108	1.086	1.155
Arkhangelsk Oblast	0.853	0.801	0.816	0.870	0.901	0.850
Vologda Oblast	0.807	0.782	0.818	0.892	0.755	0.706
Kaliningrad Oblast	1.072	1.012	1.009	0.977	1.006	1.006
Leningrad Oblast	0.910	0.943	0.921	0.943	0.926	0.916
Murmansk Oblast	0.946	0.958	0.967	1.010	1.024	1.049
Novgorod Oblast	0.824	0.834	0.829	0.845	0.875	0.958
Pskov Oblast	0.540	0.681	0.724	0.811	0.784	0.803
Saint Petersburg	2.050	2.132	2.056	2.005	2.135	2.156

Table 6

The distribution of NWFO subjects in terms of innovative capacity

№	Level of innovation potential	Value	Regions
1	Extremely low	Less than 1.0	Vologda Oblast, Pskov Oblast, Arkhangelsk Oblast, Leningrad Oblast, Republic of Karelia, Novgorod Oblast
2	Low	From 1.0 to 1.3	Republic of Komi, Kaliningrad Oblast, Murmansk Oblast
3	Average	From 1.3 to 1.6	—
4	High	More than 1.6	Saint Petersburg

Using the results obtained, it is possible to identify 4 groups of regions according to the level of innovative potential (Tab. 6): extremely low, low, medium and high. It is worth noting that most of the subjects of the Northwestern Federal District have a low level of innovative potential at the moment, which once again indicates the need to introduce incentive measures from the state.

To build a forecast, it is possible to use the regression analysis method (1):

$$y = -415163 - 0.068x_1 - 0.081x_2 - 0.973x_4 - 2194x_5 + 7864x_7 + 4696x_8 - 3351884x_9 + 362876x_{11} + 403225826x_{14} + 6.959x_{15} + 1.351x_{18} + \varepsilon, \quad (1)$$

where y – the volume of innovative goods and services, million rubles;

x_1 is the export of technology and technical services, mln;

x_2 is the import of technology and technical services, mln;

x_4 is the GRP per capita of the region, rubles;

x_5 is the number of personal computers per 100 workers in the region, in units;

x_7 is the share of personnel engaged in research and development s in the total number of employees in the regional economy;

x_8 are the R&D expenditures per 10 thousand workers in the region, mln;

x_9 is the number of scientific organizations per 10,000 workers in the region;

x_{11} is the number of created objects of intellectual property per 10,000 workers in the region's economy;

x_{14} is the share of organizations engaged in research and development in the total number of enterprises in the region;

x_{15} are the advanced production technologies used, units;

x_{18} are the costs for technological innovation, mln;

ε is the random deviation.

To fulfill the forecast, 3 development options were calculated: with the maintenance of current trends (Tab. 7), with the improvement of the values of factors (Tab. 8), with a decrease in the values of factors (Tab. 9). Provided that the same growth rates are maintained over the next ten years, we obtain the following values for the volume of innovative goods, works and services.

Option 1. Maintaining current trends in the development of the Northwestern Federal District

Table 7

Forecast of the volume of innovative goods, works and services

Year	Volume of innovative goods and services, million rubles.	Year	Volume of innovative goods and services, million rubles.
2015	446981.9	2021	1438913.4
2016	555169.2	2022	1713202.4
2017	681689.2	2023	2033053.5
2018	829538.6	2024	2405972.9
2019	1002205.9	2025	2840724.1
2020	1203753.3		

Option 2. Positive growth of independent factors

In the second case, where the growth of all indicators included in the regression model was taken into account, the volume of innovative goods and services was systematically increasing from year to year at a much higher rate than in the first variant (Tab. 8)

In the third case, a pessimistic option was calculated, where the growth rates of all indicators were negative. It turned out that even a slight decrease in the parameters included in the linear regression equation leads to a significant decrease in the volume of innovative goods, works and services (Tab. 6).

Table 8

Year	Volume of innovative goods and services, million rubles.	Year	Volume of innovative goods and services, million rubles.
2015	454588.2	2021	1539882.6
2016	571756.9	2022	1844954.8
2017	709045.7	2023	2203334.5
2018	869972.5	2024	2624553.2
2019	1058682.3	2025	3119899.8
2020	1280062.9		

Option 3. Pessimistic option

Table 9

Year	Volume of innovative goods and services, million rubles.	Year	Volume of innovative goods and services, million rubles.
2015	342998.0	2021	273859.3
2016	331431.3	2022	262475.9
2017	319865.5	2023	251158.6
2018	308313.8	2024	239915.4
2019	296788.2	2025	228753.7
2020	285299.9		

Thus, the obtained linear model has a high degree of reliability and allows to predict the volume of innovative goods, works and services produced in the Northwestern Federal District with a minimum deviation. The considered variants of the forecast confirm the necessity of constant monitoring of the innovation situation in the region, since even a small decrease in the parameters leads to a significant decrease in the resultant factor.

Conclusions. Based on the results obtained, the following conclusions were drawn:

1. The Northwestern Federal District as a whole has a high rate of current innovation activity. However, the majority of economical entities (Pskov, Novgorod, Arkhangelsk regions and the Republic of Karelia) is characterized by a low level of innovative activity. The main innovative economic actors in the region are the city of St. Petersburg and the Kaliningrad Oblast. The method of assessment includes an analysis of various spheres of economic activity, which

allows to use the results of the analysis in the development of measures to stimulate innovation and investment activity in economic entities.

2. St. Petersburg has the greatest value of the innovation potential evaluation index, which can be explained not only by the high level of development in all spheres of the economy, but also by its favorable economic and geographical position. At the same time, many NWFD entities are characterized by a low level of innovative potential of subjects. Therefore, in order to stimulate innovative activity necessary in the subjects of the federation it is necessary to:

- improve the technological equipment of the economic entities (increase in investments in fixed assets);
- strengthen the financial and economic status of the subjects by attracting major investors and business angels; facilitate tax and customs privileges);
- improve the efficiency of information and communications technologies subjects, through the provision of subsidies for the development of ICT, as well as the formation of the state order for production and implementation of IT-technologies.

3. The forecast of innovative products, works and services produced in all subjects in the Northwestern Federal District in 2015–2025 has been made in this paper. The data show how strongly the resulting factor depends on the variables of the equation: a slight reduction in the growth rate of variables leads to a significant reduction in the volume of innovative products in the region.

In view of the above, it must be also mentioned that the measures of state stimulation of innovation activity can and should significantly improve the innovation and investment activities in the economic subjects of the federation, which ultimately has a positive effect on increasing the innovation potential of the entire Northwestern Federal District, and on increasing the volume of the much-needed innovative products.

Directions for further research. In the course of further research, the measures of the governmental regulation which can best stimulate the innovative activity of enterprises will be studied in more detail; in addition, the roles of business incubators, technology parks and technopolises in the formation of regional innovation systems will be studied.

REFERENCES

- [1] O nauke i gosudarstvennoi nauchno-tehnicheskoi deiatel'nosti [On science and state scientific-technical activities], Feder. zakon № 127-FZ, s izm. na 13.07.2015 g.
- [2] S.G. Alekseev, Ekonomicheskie problemy regionov i otraslevykh kompleksov [Economic problems of regions and branch complexes], Problemy sovremennoi ekonomiki, 2(30) (2009).
- [3] I.M. Bortnik, V.G. Zinov, Indikatory innovatsionnogo razvitiia regionov Rossii dlia tselei monitoringa i upravleniia [Indicators of innovative development of Russian regions for the purposes of monitoring and control], Innovatsii, 11(181) (2013) 2–13.
- [4] S.P. Bystritskii, V.K. Zausaev, I.Iu. Krivoruchko, Innovatsionnyi potentsial vostochnykh regionov Rossii [Innovative potential of Russia's Eastern regions], EKO, (10) (2005) 40–52.
- [5] A.S. Dubinin, Sushchnost' i metody otsenki innovatsionnoi aktivnosti regiona [The nature and methods of evaluation of innovative activity in the region], Vestnik Novgorodskogo gosudarstvennogo universiteta, (61) (2011) 27–30.
- [6] P. Druker, Biznes i innovatsii [Business and innovation]: per. s angl. Izd. dom Vil'iams, Moscow, 2007. 432 p.
- [7] E.V. Erokhina, Innovatsionnaia aktivnost' regiona: problemy, otsenka i vozmozhnosti stimulirovaniia [Innovative activity of region: problems, assessment, and opportunities to promote], Obshchestvo: politika, ekonomika, pravo, (2) (2015) 67–71.
- [8] Issledovanie KPMG «Perspektivy mirovogo promyshlennogo sektora. Boevaia gotovnost' nomer odin: promyshlennyi sektor gotovitsia k transformatsii» [The KPMG study «The prospects of the global industrial sector. Combat readiness number one: the industrial sector is preparing for transformation»], 2015 g. URL: <http://www.kpmg.com/ru/ru/issuesandinsights/articlespublications/pages/global-manufacturing-outlook-2015.aspx>
- [9] D.P. Malyshev, O.S. Petrova, Innovatsionnaia deiatel'nost' v sub"ektakh Rossiiskoi Federatsii: problemy i perspektivy razvitiia [Innovative activities in the constituent entities of the Russian Federation: problems and prospects], Pskovskii regionologicheskii zhurnal, (15) (2013) 48–62.
- [10] E.A. Mil'skaia, Strategicheskoe upravlenie innovatsionno-aktivnym predpriiatiem [Strategic management of innovation-active enterprise], Izd-vo Politekhn. un-ta, St. Petersburg, 2011. 296 p.

[11] **E.A. Mil'skaia**, Innovatsionno-promyshlennaia politika gosudarstva kak faktor realizatsii innovatsionnogo potentsiala predpriatii [Innovative industrial policy of the state as the factor of realization of innovative potential of enterprises], Teoreticheskie osnovy formirovaniia promyshlennoi politiki. Pod red. prof. A.V. Babkina, Izd-vo Politekhn. un-ta, St. Petersburg, 2015.

[12] **G.N. Moskalenko**, Innovatsii i metody otsenki ikh effektivnosti [The innovations and methods to assess their effectiveness], 2012 g. URL: <http://journal-ael.intelbi.ru/main/wp-content/uploads/2011/04/G.N.-Moskalenko.pdf>

[13] **T.V. Pogodina**, Ekonomicheskii analiz i otsenka innovatsionnoi aktivnosti i konkurentosposobnosti regionov Privolzhskogo federal'nogo okruga [Economic analysis and estimation of innovative activity and competitiveness of the Volga Federal district], Ekonomicheskii analiz: teoriia i praktika, (5) (2004) 16–22.

[14] Reiting innovatsionnykh regionov: dlia tselei monitoringa i upravleniia: versii 2015-1.0 [Rating of innovative regions: for the purposes of monitoring and management: version 2015-1.0], Assotsiatsiia innovatsionnykh regionov Rossii. URL: http://www.i-regions.org/files/file_47.pdf.

[15] Publikatsiia Federal'noi sluzhby gosudarstvennoi statistiki «Promyshlennost' Rossii» [Publication of the Federal state statistics service «Industry of Russia»], 2014 god. URL: <http://www.gks.ru:statistics/publications>

[16] Federal'naia sluzhba gosudarstvennoi statistiki. Regiony Rossii. Sotsial'no-ekonomicheskie pokazateli [Federal state statistics service. The Regions Of Russia. Socio-economic indicators] – 2015 g.

Mil'skaya E.A. E-mail: santa-2000@mail.ru

Buchkova, A.V. E-mail: nastybuchkova@ya.ru

[17] Regiony Rossii. Sotsial'no-ekonomicheskie pokazateli 2015 [The Regions Of Russia. Socio-economic indicators 2015]: ofits. sait feder. sluzhby gos. statistiki RF. URL: http://www.gks.ru/bgd/regl/b15_14p/Main.htm

[18] Reiting innovatsionnykh regionov: dlia tselei monitoringa i upravleniia: versii 2015-1.0 [Rating of innovative regions: for the purposes of monitoring and management: version 2015-1.0], Assotsiatsiia innovatsionnykh regionov Rossii. URL: http://www.i-regions.org/files/file_47.pdf

[19] **I.N. Rykova**, Metodicheskie aspekty otsenki innovatsionnogo razvitiia regionov i monitoringa rezul'tatov innovatsionnoi deiatel'nosti (na primere g. Moskvy) [Methodological aspects of evaluation of innovative development of the regions and monitoring the results of innovation activity (on the example of Moscow)], Doklad instituta innovatsionnoi ekonomiki Finuniversiteta. – 2012 g. URL: http://www.fa.ru/institutes/efo/Documents/Rykova_04.10.2012.pdf

[20] **E.V. Pustynnikova**, Protsessy integratsii ekonomicheskikh sistem v regional'nye klasteri (na primere Ul'ianovskoi oblasti) [The process of integration of economic systems in regional clusters (by the example of Ulyanovsk region)]. Ministerstvo obrazovaniia i nauki Rossiiskoi Federatsii, Gos. obrazovatel'noe uchrezhdenie vyssh. prof. obrazovaniia Ul'ianovskii gos. un-t. Ul'ianovsk, 2011.

[21] **A.O. Novikov, A.V. Babkin**, Innovatsionnaia sistema predpriatii: sostoianii i perspektivy razvitiia [The innovative system of the enterprise: state and prospects of development], St. Petersburg State Polytechnical University Journal. Economics, 4(61) (2008) 208–218.

СПИСОК ЛИТЕРАТУРЫ

[1] О науке и государственной научно-технической деятельности : Федер. закон № 127-ФЗ, с изм. на 13.07.2015 г.

[2] **Алексеев С.Г.** Экономические проблемы регионов и отраслевых комплексов // Проблемы современной экономики. 2009. № 2(30).

[3] **Бортник И.М., Зинов В.Г.** Индикаторы инновационного развития регионов России для целей мониторинга и управления // Инновации. 2013. № 11(181). С. 2–13.

[4] **Быстрицкий С.П., Заусаев В.К., Криворучко И.Ю.** Инновационный потенциал восточных регионов России // ЭКО. 2005. № 10. С. 40–52.

[5] **Дубинин А.С.** Сущность и методы оценки инновационной активности региона // Вестник Новгородского государственного университета. 2011. № 61. С. 27–30.

[6] **Друкер П.** Бизнес и инновации: пер. с англ. М.: Изд. дом Вильямс, 2007. 432 с.

[7] **Ерохина Е.В.** Инновационная активность региона: проблемы, оценка и возможности стимулирования // Общество: политика, экономика, право. 2015. № 2. С. 67–71.

[8] Исследование КПМГ «Перспективы мирового промышленного сектора. Боевая готовность номер один: промышленный сектор готовится к трансформации», 2015 г. URL: <http://www.kpmg.com/ru/ru/issuesandinsights/articlespublications/pages/global-manufacturing-outlook-2015.aspx>

[9] **Мальшев Д.П., Петрова О.С.** Инновационная деятельность в субъектах Российской Федерации: проблемы и перспективы развития // Псковский регионологический журнал. 2013. № 15. С. 48–62.

- [10] **Мильская Е.А.** Стратегическое управление инновационно-активным предприятием. СПб.: Изд-во Политехн. ун-та, 2011. 296 с.
- [11] **Мильская Е.А.** Инновационно-промышленная политика государства как фактор реализации инновационного потенциала предприятий // Теоретические основы формирования промышленной политики / под ред. проф. А.В. Бабкина. СПб.: Изд-во Политехн. ун-та, 2015.
- [12] **Москаленко Г.Н.** Инновации и методы оценки их эффективности, 2012 г. URL: <http://journal-aael.intelbi.ru/main/wp-content/uploads/2011/04/Г.Н.-Москаленко.pdf>
- [13] **Погодина Т.В.** Экономический анализ и оценка инновационной активности и конкурентоспособности регионов Приволжского федерального округа // Экономический анализ: теория и практика. 2004. № 5. С. 16–22.
- [14] Рейтинг инновационных регионов: для целей мониторинга и управления: версия 2015-1.0 // Ассоциация инновационных регионов России. URL: http://www.i-regions.org/files/file_47.pdf.
- [15] Публикация Федеральной службы государственной статистики «Промышленность России», 2014 год. URL: <http://www.gks.ru: statistics/publications>
- [16] Федеральная служба государственной статистики. Регионы России. Социально-экономические показатели – 2015 г.
- [17] Регионы России. Социально-экономические показатели 2015: офиц. сайт федер. службы гос. статистики РФ. URL: http://www.gks.ru/bgd/regl/b15_14p/Main.htm
- [18] Рейтинг инновационных регионов: для целей мониторинга и управления: версия 2015-1.0 // Ассоциация инновационных регионов России. URL: http://www.i-regions.org/files/file_47.pdf
- [19] **Рыкова И.Н.** Методические аспекты оценки инновационного развития регионов и мониторинга результатов инновационной деятельности (на примере г. Москвы) // Доклад института инновационной экономики Финуниверситета. – 2012 г. URL: http://www.fa.ru/institutes/efo/Documents/Рыкова_04.10.2012.pdf
- [20] **Пустынникова Е.В.** Процессы интеграции экономических систем в региональные кластеры (на примере Ульяновской области) / Министерство образования и науки Российской Федерации, Гос. образовательное учреждение высш. проф. образования Ульяновский гос. ун-т. Ульяновск, 2011.
- [21] **Новиков А.О., Бабкин А.В.** Инновационная система предприятия: состояния и перспективы развития // Научно-технические ведомости СПбГПУ. Экономические науки. 2008. № 4(61). С. 208–218.

Мильская Е.А. E-mail: santa-2000@mail.ru

Бычкова А.В. E-mail: nastybuchkova@ya.ru

Статья поступила в редакцию 28.02.17

DOI: 10.18721/JE.10205
UDC 658.012.5

OPERATIONS MANAGEMENT: CONVERTING MANUFACTURING CAPITAL IN MANUFACTURING-TECHNOLOGICAL SYSTEMS OF ENGINEERING BUSINESS

A.N. Shichkov

Vologda State University, Vologda, Russian Federation

The article is dedicated to rethinking Kondratyev's research of economic environment in countries having the developed market economy. The methodology and the results of his research allowed us to conclude that there is no national economy, but there are national economic models. The initial parameters in these models are the needs of people ensuring their life activity. These conclusions have been made by analyzing prior indicators of different countries and the improvement rate of technological and manufacturing assets. Kondratyev's waves are the results of human activity in an objective economic environment directed at fulfilling people's needs. Shumpeter also suggested improving economic models based on continuous human needs in innovative products, technologies and efficient manufacturing structures. To respond to these challenges, we offer to use the first and second laws of thermodynamics. Based on these laws we have developed a mathematical model for converting manufacturing capital into monetary capital in the form of produced and sold products and services. The studies of a conversion operating cycle in real engineering business have shown that the market cost of business on the stock market and its result in the form of sold products are determined by a criterial equation including five similarity criteria. The mathematical model of operations management has been created based on an operating cycle converting the manufacturing capital into monetary capital in the form of produced and sold products and services. Further research will be dedicated to extending this approach in evaluative technologies of tangible and intangible assets, estimation of business by the market capital method, designing innovative projects, organization of manufacturing processes based on transfer operating costs within technological stages being at the same time the zones financial responsibility, organization of management accounting.

Keywords: conversion operating cycle in engineering business; operations management; criterial equation of conversion operating cycle; similarity criteria of operating cycle.

Citation: A.N. Shichkov, Operations management: converting manufacturing capital in manufacturing-technological systems of engineering business, St. Petersburg State Polytechnical University Journal. Economics, 10 (2) (2017) 54–63. DOI: 10.18721/JE.10205

ОПЕРАЦИОННЫЙ МЕНЕДЖМЕНТ: КОНВЕРСИЯ ПРОИЗВОДСТВЕННОГО КАПИТАЛА В ПРОИЗВОДСТВЕННО-ТЕХНОЛОГИЧЕСКИХ СИСТЕМАХ ИНЖЕНЕРНОГО БИЗНЕСА

А.Н. Шичков

Вологодский государственный университет, г. Вологда, Российская Федерация

Статья посвящена переосмыслению исследований Н.Д. Кондратьева экономической среды стран, имеющих развитую рыночную экономику. Методология и результаты исследований Н.Д. Кондратьева позволили сделать вывод, что нет национальной

экономики, а есть национальные экономические модели, где исходными параметрами являются потребности людей, обеспечивающие их жизнедеятельность. Вывод сделан на основе анализа приоритетных индикаторов каждой страны и темпов совершенствования технологических и производственных активов. Волны Н.Д. Кондратьева – это результат деятельности людей в объективной экономической среде, направленной на реализацию потребностей людей. В этой связи вполне объяснимо предложение И. Шумпетера совершенствовать экономические модели на основе потребностей людей в новых продуктах, технологиях и организации производственных процессов. Для реализаций этих задач, как правило, используют объективные природные законы. В основе планетарной теории атома и химических элементов и технологий использован закон всемирного тяготения. Нами предложено использовать объективные законы термодинамики и теорию потенциального поля. На основе этих законов создан математический аппарат конверсии производственного капитала в денежный капитал в форме реализованной продукции. Исследования реального инженерного бизнеса показали, что стоимость бизнеса на фондовом рынке и его результат в форме реализованной продукции определяются критериальным уравнением, состоящим из пяти критериев. Разработана математическая модель операционного менеджмента на основе операционного цикла конверсии производственного капитала в денежный капитал в форме произведенной и реализованной продукции. Дальнейшие исследования будут направлены на расширение использования этого подхода в оценочной инновационной деятельности.

Ключевые слова: конверсия операционного цикла инженерного бизнеса; операционный менеджмент; критериальное уравнение операционного цикла конверсии; критерии подобия операционного цикла

Ссылка при цитировании: Шичков А.Н. Операционный менеджмент: конверсия производственного капитала в производственно-технологических системах инженерного бизнеса // Научно-технические ведомости СПбГПУ. Экономические науки. 2017. Т. 10. № 2. С. 54–63. DOI: 10.18721/JE.10205

Introduction

Kondratyev's research of an economic environment of countries with developed market economy. N.D. Kondratyev studied the dynamics of cyclic economic processes of the indicators of infrastructure subjects which generate the people's needs ensuring their life activity. Kondratyev considered the indicators from the late 18th century up to the early 20th century (about 150 years) in the following countries:

- a) in the United Kingdom: prices; interest on capital; wages of agricultural and textile workers; production coal, iron and lead;
- b) in France: prices; interest on capital; foreign trade; coal consumption; the planting area of oats; the portfolio of the French Bank; deposits in saving banks; consumption of cotton, coffee, sugar;
- c) in Germany: the production of coal and steel;
- d) in the United States of America: prices; the production of coal, iron and steel; the number of spindles in the cotton industry; cotton acreage;
- e) indicators of production and consumption are not overall, but per capita.

The analysis of the research results allows to formulate the main properties of every infrastructure subject in an economic environment.

1. Cyclic changes of the indicators are continuous; based on the property of self-organization, their oscillation amplitude takes an average value. Non-stationary oscillatory processes become stationary.

2. The synergic effect ($2 + 2 = 5$) in an integrated set of infrastructure subjects in an economic environment is achieved by the property of self-organization.

3. Economic environment as a result of manufacturing capital conversion is a vector field of monetary flows. A thermodynamic system has similar properties. In this system, the heat flow vectors arise based on a temperature gradient. Therefore, the economic environment is a field whose infrastructure subjects have cyclic, self-organization and synergetic properties.

Based on the mathematical analogy of thermodynamic and economic systems, we conclude that operation management considers economy as an objective law. According to the first and second thermodynamic laws, the infrastructure subjects in an economic environment convert manufacturing capital into monetary capital in the form of produced and sold products and services necessary and sufficient for ensuring the life activities of people.

The Carnot thermodynamic cycle converts heat energy into mechanical work. An ideal closed cycle consists of two isotherms and two adiabats. In this case a real conversion cycle is placed inside an ideal closed conversion cycle.

The mathematical analogy of converting the operating cycle in thermodynamic and manufacturing-technological systems (based on the first and second laws of thermodynamics) allowed to formulate and substantiate the theoretical and practical tools to design, plan and control the innovative development of manufacturing-technological systems of engineering business.

Research objectives. Our aim is to develop a mathematical model of operation management based on converting manufacturing capital into monetary capital in the form of produced and sold products. The mathematical models of the first and second thermodynamics laws have been used as paradigms for developing an operations management model. One of our main objectives is to study the operating cycle of real metallurgical enterprises on the basis of these models using the information from the stock market as initial data.

Research methods

The ideal operational cycle of converting manufacturing capital into monetary capital consists of five unit vectors:

Q is the manufacturing capital of the conversion operating cycle which is equal to the sum of technological costs $G_0W_0 = C_{mc} + C_{lp} + C_{oc}$, where C_{mc} are the material costs; C_{lp} are the labor payment costs; C_{oc} are the other costs (without amortization of intangible assets) and $U_{mf} = U_{ta} + U_{ia}$ are the main funds of a manufacturing-technological system, including the tangible assets U_{ta} and the intangible assets U_{ia} .

V_{sv} is the sales value of the manufactured products (services) which is equal to the sum of net income D_0 , including P_0 which is the net profit (property of business owners); C_{dta} which is the depreciation of tangible assets, C_{aia} which is the amortization of intangible assets. The monetary equivalent of products manufactured in a conversion operating cycle $(G_0W_0)_{sv}$ is numerically equal to technological costs (G_0W_0) .

In turn, the sum of amortization of intangible assets and depreciation of tangible assets $C_{dta} + C_{aia} = C_{ma}$ is the necessary and sufficient capital for simple and extended reproduction of the main funds in a manufacturing-technological system.

The balance equation for converting the manufacturing capital into monetary capital in the form of produced and sold products has the form:

$$\frac{Q}{U_{mf} + G_0W_0} = \frac{V_{sv}}{D_0 + (G_0W_0)_{sv}} \quad (1)$$

by analogy with the adiabatic process $G_0W_0 = (G_0W_0)_{sv}$.

The level of conversion is equal to the relation of the sales value to the manufacturing capital. The parametric equation has the form:

$$\frac{V_{sv}}{Q} = \frac{(G_0W_0)_{sv} + D_0}{G_0W_0 + U_{mf}} = \leq 1. \quad (2)$$

Our research shows that the conversion level for the ideal operating cycle is equal to one while for the real converting operating cycle (according to second thermodynamic law) it is less than one. The conversion level is more than one for the excise business.

Let us write Eq. (2) in a dimensionless form:

$$\frac{V_{sv}}{Q} = \frac{\frac{V_{sv}}{(G_0W_0)_{sv}}}{\frac{Q}{G_0W_0}} = \frac{\frac{(G_0W_0)_{sv}}{U_{mf}} + \frac{D_0}{U_{mf}}}{\frac{G_0W_0}{U_{mf}} + 1} = \vartheta. \quad (3)$$

Let us introduce the notion of dimensionless complexes and write Eq. (3) in a dimensionless form:

$$\vartheta = \frac{\lambda}{\rho} = \frac{k_0 + M}{k_0 + 1} = \frac{k_0}{k_0 + 1} + \frac{M}{k_0 + 1} = \vartheta_{mts} + \vartheta_{bus}. \quad (4)$$

The dimensionless complexes in Eq. (4) are similarity criteria and therefore Eq. (4) is a similarity equation, where:

$$\vartheta = \frac{V_{sv}}{Q} \text{ is the conversion criterion of the}$$

operating cycle equal to the sum of conversion criteria: ϑ_{mts} is the manufacturing-technological system criterion and ϑ_{bus} is the criterion of the enterprise. This criterion has a very impotent property for engineering business. Namely,

the operations cycles are similar if the numerical values of their conversion criteria are equal. Theory of similarity is widely used for research in thermodynamic systems. Eq. (4) allows applying the methods of similarity theory for research of manufacturing-technological systems.

Similar processes take place in the Carnot cycle where the first part of conversion is a thermodynamic cycle and the second part is converting the thermodynamic cycle into mechanical work. Each conversion cycle is improved by self-innovations. Each part of the conversion cycle is improved by self-innovations.

Our research of the factors determining the level of conversion in a real engineering business has shown that it primarily depends on the physical fundamentals of the technological process. For example, if turning with a low material utilization coefficient is substituted by plastic deformation (forging, stamping, rolling, i.e., breakthrough technological innovations) with a much higher utilization coefficient, then the conversion level of the operating cycle will increase. Therefore, «incremental» improving technological innovations cannot increase the level of conversion.

$k_0 = \frac{G_0 W_0}{U_{mf}}$ is the criterion (characteristic) of an operational cycle. The value of this criterion for an ideal operating cycle is equal to $k_0 = 1$, while for a real operating cycle this is a constant $k_0 < 1$. Therefore, the variation range of the

conversion criteria of the engineering business can be written in the form:

$$\vartheta \leq \vartheta_{mts} + \vartheta_{bus} \leq 0,5 + 0,5 \leq 1. \quad (5)$$

Our research has shown that the inequality $\vartheta_{mts} \leq 0,5 \geq \vartheta_{bus}$ takes place. In this case, the design and subsequent adjustments should ensure equality $\vartheta_{mts} = \vartheta_{bus}$ of the conversion criteria of the manufacturing-technological system (mts) and of the business (bus).

$M = \frac{D_0}{U_{mf}}$ is the criterion of self-financing

of simple and expanded reproduction of the main funds at the expense of the depreciation and amortization funds of the enterprise and financing dividends at the expense of the net operation profit. This criterion must be equal to or less than the conversion criterion of the manufacturing-technological system $\vartheta_{mts} \geq \vartheta_M$.

$\lambda = \frac{V_{sv}}{(G_0 W_0)_{sv}}$ is the conversion criterion of a

marketing enterprise.

$\rho = \frac{Q}{G_0 W_0}$ is the conversion criterion of

technological processing,

where $\vartheta = \frac{\lambda}{\rho}$.

Fig. 1 presents a block diagram of operations management based on the conversion operating cycle in a manufacturing-technological system (MTS).

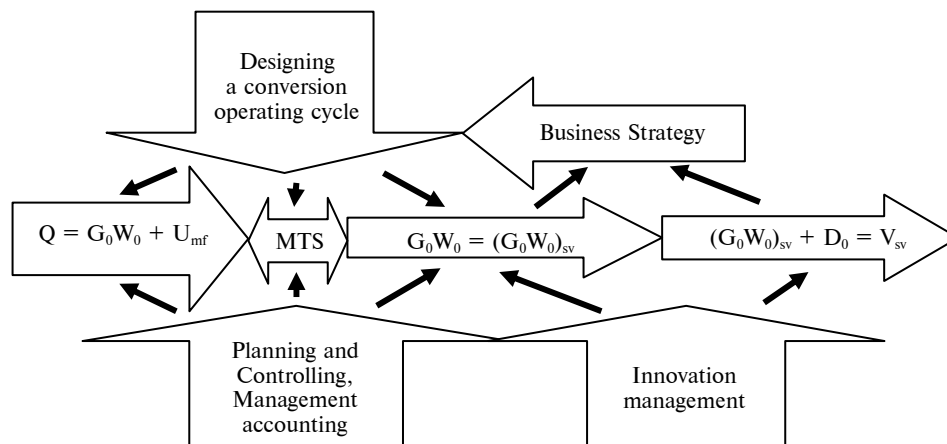

Fig. 1. Block-diagram of an operations management infrastructure based on the conversion operating cycle in a manufacturing-technological system (MTS)

Operations management is an economic system whose infrastructure is implemented by self-managed engineering business in an economic environment. To continuously manufacture products with competitive advantages in the domestic and foreign markets, the work cycle should be supplemented by creating the **strategy** based on marketing information about the demand and supply of innovative products and technologies. The algorithm for developing the strategy is as follows. After the function of operations has understood its role in business and after it has formulated its efficiency goals, it needs to formulate a set of general principles that will determine its decision-making.

The first stage: enterprises should understand their main role (mission) in a municipal territory. Labor market ensures the workplaces of a municipal territory, and that is the main need of humans for their life activity.

The second stage: enterprises should articulate the performance objectives. They increase the conversion level of the manufacturing capital by continuous implementation of innovation-investment projects, and on this basis they increase their sales value.

The third stage: enterprises should formulate a set of general principles which will guide their decision-making. The organization of production should ensure the competitive advantages of consumer properties of each technological stage being the zone of financial responsibility. It means the manufacturing technological system of an enterprise should ensure the transfer of technological costs and consumer properties within technological stages. In this case management accounting or controlling are applied.

This information is initial for **designing** an organization production by transferring technological costs and consumer properties (market cost) of products or technological stages within the zones of financial responsibility. In this case **management accounting** will allow implementing the main condition of an innovative organization production ensuring the market cost in each technological stage. By using **innovative management tools**, enterprises continuously

improve the parameters of conversion operating cycles and conversion marketing tools.

The manufacturing capital Q is converted into monetary capital in the form of sales value V_{sv} in an operating cycle of conversion consisting of two stages. The first stage is a manufacturing-technological stage with the following condition: technological costs are equal to the market value of the manufactured products:

$$G_0W_0 = (G_0W_0)_{sv}. \quad (6)$$

The second stage of conversion is the marketing conversion where net income D_0 is added to the market value of products $(G_0W_0)_{sv}$, which is necessary and sufficient for paying taxes of all levels, dividends in the form of net profit P_0 and capital maintenance adjustments $C_{mac} = C_{dtc} + C_{aic}$.

Designing management accounting in a conversion operating cycle

Competitive advantages of products and technologies of engineering business are implemented on the basis of «incremental» and «breakthrough» innovative projects. In this case managers of engineering enterprises obtain the required consumer properties of products by management accounting using the transfer of technological costs and market cost within technological stages being zones of financial responsibility. The organization of a conversion operating cycle based on management accounting is the necessary condition for implementing any innovative projects. In this case, the competitive advantages of end products are formed by the transfer of technological costs and the cost of consumer properties in each technological stage, considering the parameters of an innovation project.

The mathematical model for management accounting ensures the competitive advantages based on the transfer of the set of cumulative properties of a conversion operating cycle.

Balance equation of the sales value V_{sv} for four technological stages:

$$\begin{aligned} V_{sv} = V_{sv1} \rightarrow V_{sv2} &= \sum_{n=1}^{n=2} V_{svn} \rightarrow V_{sv3} = \\ &= \sum_{n=1}^{n=3} V_{svn} \rightarrow V_{sv4} = \sum_{n=1}^{n=4} V_{svn}. \end{aligned}$$

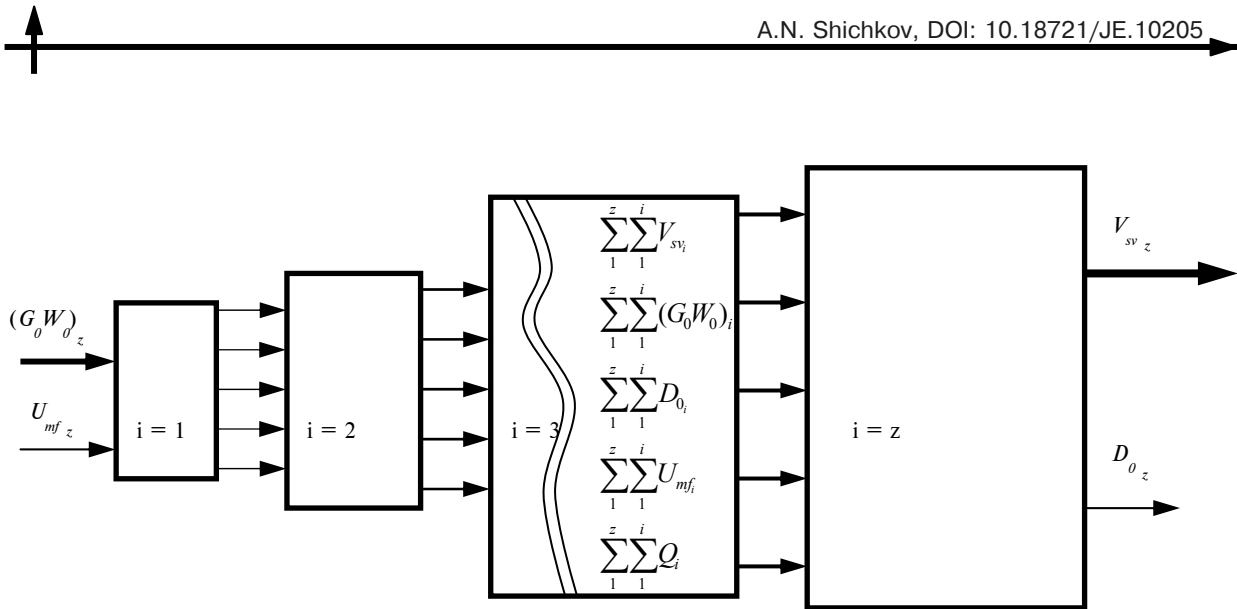

Fig. 2. Block diagram of transferring parameters of a conversion operating cycle

Balance equation of manufacturing costs:

$$\begin{aligned} (G_0 W_0) &= (G_0 W_0)_1 \rightarrow (G_0 W_0)_2 = \\ &= \sum_{n=1}^{n=2} (G_0 W_0)_n \rightarrow (G_0 W_0)_3 = \\ &= \sum_{n=1}^{n=3} (G_0 W_0)_n \rightarrow (G_0 W_0)_4 = \sum_{n=1}^{n=4} (G_0 W_0)_n. \end{aligned}$$

Balance equation of net income:

$$\begin{aligned} D_0 &= D_{01} \rightarrow D_{02} = \sum_{n=1}^{n=2} D_{0n} \rightarrow D_{03} = \\ &= \sum_{n=1}^{n=3} D_{0n} \rightarrow D_{04} = \sum_{n=1}^{n=4} D_{0n}. \end{aligned}$$

Balance equation of manufacturing capital:

$$\begin{aligned} Q &= Q_1 \rightarrow Q_2 = \sum_{n=1}^{n=2} Q_n \rightarrow Q_3 = \\ &= \sum_{n=1}^{n=3} Q_n \rightarrow Q_4 = \sum_{n=1}^{n=4} Q_n. \end{aligned}$$

Graphical interpretation of the conversion operating cycle in manufacturing-technological systems of engineering business. The sum of collinear vectors is a single vector, while the sum of two orthogonal vectors is a right-angled triangle.

Therefore, the ideal converting operating cycle of manufacturing-technological system is an equilateral triangle consisting of five unit vectors of monetary flows. In this case, the graphical interpretation of the criterial Eq. (4)

for a conversion operating cycle in vector form is the following:

$$\frac{\vec{V}_{sv}}{\vec{Q}} = \frac{k_0 (\vec{G}_0 \vec{W}_0)_{sv} + M \vec{D}_0}{k_0 (\vec{G}_0 \vec{W}_0) + 1 \vec{U}_{mf}}. \quad (7)$$

An ideal conversion operating cycle is presented in Fig. 3.

The operating cycle of converting manufacturing capital into monetary capital in the form of the sales value of products and services consists of two closed cycles. The first closed operating cycle of converting manufacturing capital into products 1-3-4 consists of three vectors of monetary flows $\vec{Q} = \vec{G}_0 \vec{W}_0 + \vec{U}_{mf}$. This contour is a manufacturing cycle, where the end product (or technological stage) with the market cost that is equal to the technological costs $(\vec{G}_0 \vec{W}_0)_{mf} = \vec{G}_0 \vec{W}_0$ is manufactured as a result of converting the manufacturing capital. The second cycle 1-2-3 consists of three unit vectors $\vec{V}_{sv} = (\vec{G}_0 \vec{W}_0)_{sv} + \vec{D}_0$ of monetary flows. This is a marketing cycle. A real operating cycle of converting the manufacturing capital is placed inside an ideal operating cycle. The criteria k_0 -M are a coordinate system for the real operating cycle of conversion. For example, the criterion of conversion in a real operating cycle 1¹-2¹-4 at $k_0 = 0.40$ and $M = 0,35$, $\vartheta = \frac{0.40 + 0.35}{0.40 + 1} = 0.54$.

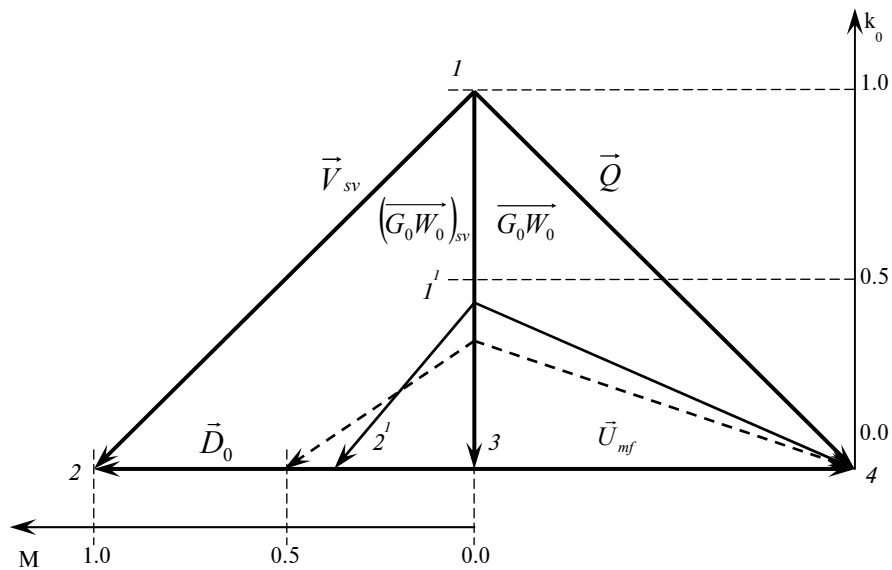

Fig. 3. Graphical interpretation of the conversion operating cycle in a manufacturing-technological system

Table 1

**Conversion criteria for the operating cycles of similar metallurgical enterprises:
«Magnitogorsk Metallurgical Company» (MMC), «Novolipetsk Metallurgical Company» (NLMC)
and «Cherepovets Steel Mill» (ChMC)**

Similar enterprises on stock market	JSC «MMC»	JSC «NLMC»	JSC «CHMC»
Stock market parameters, mln USD			
Sales value, V_{sv}	5380.00	4468.73	5055.17
Sales value without taxes and payment	4983.37	3996.36	4617.31
Profitability of sales, $r = P/V_{sv}$	24.6%	41.6%	35.2%
Net profit, P_0	947.00	1385.34	1312.00
Operation profit, P	1323.48	1859.00	1779.42
Parameters of a conversion operating cycle			
Operation costs $C_{oc} = V_{sv} - P$	4056.52	2609.74	3275.75
Sum of tax fixed assets and tax of operating profit $\Delta P = P - P_0 = N_{fa} + N_p$	376.48	473.66	467.42
Tax on operating profit $N_p = P_0 \psi_p / (1 - \psi_p)$, where $\psi_p = 0.2$ is the tax rate on operating profit	236.75	348.34	328.00
Tax on fixed assets (tax on equity of entity) $N_{fa} = \Delta P - N_p$	139.73	125.32	139.42
Main funds U_{mf} for these enterprises are fixed assets (tangible assets) U_{mf} / ψ_{fa} , where $\psi_{fa} = 0.02$ is the tax rate for fixed assets	6986.50	6266.00	6971.00
Depreciation (amortization) of tangible assets $C_{dc} = \alpha_{dt} U_{fa} = 0.03 U_{fa}$, where α_{dt} is the rate of depreciation (amortization)	209.60	188.00	209.13
Technological costs $G_0 W_0 = C_{oc} - C_{dc}$	3846.92	2421.74	3066.62
Net income $D_0 = P_0 + C_{dc}$	1156.60	1573.34	1521.12
Manufacturing capital $Q = G_0 W_0 + U_{fa}$	10833.42	8687.74	10037.62
Criteria of a conversion operating cycle			
Capitalization criteria $\lambda = V_{sv} / G_0 W_0$	1.30	1.65	1.51
Investment criteria $M = D_0 / U_{mf}$	0.17	0.25	0.22
Resources criteria $\rho = Q / G_0 W_0$	2.82	3.59	3.27
Characteristic of the manufacturing capital $k_0 = G_0 W_0 / U_{mf}$	0.55	0.39	0.44
Conversion criterion $\vartheta = \frac{V_{sv}}{Q} = \frac{\lambda}{\rho} = \frac{k_0 + M}{k_0 + 1}$	0.46	0.46	0.46
The cost of equity capital on 19.04.2006	7892.94	13964.22	7452.80

Research results and discussions. Based on the information taken from Table 1, we can come to the conclusion that the enterprises are similar in terms of the similarity criterion of the conversion level. Our research has shown that the similarity criterion of the conversion operating cycle is its property that depends only on physical fundamentals of technological processes. In this case all three enterprises manufacture sheet metal based on a similar technology.

Having considered the results of criterial assessment of conversion operating cycles in three enterprises, we may suggest the following research issues for a discussion:

1. The physical basis of the enterprises' technology is absolutely similar. Despite different equipment, the conversion criterion is equal and it does not depend on the production volume. Novolipetsk Metallurgical Company is relatively new and its products are in much demand, therefore the value of its stock capital is higher than the same value in other enterprises. Its criteria ρ and λ are higher. The first criterion demonstrates that the company has more modern technological equipment; the second one shows that marketing performs much more effectively. The higher value of the criterion M indicates that the enterprise has more revenue and the lower value of business characteristic indicates that it has lower technological costs.

2. The criterial analysis allows to formulate the aims and objectives of innovative projects ensuring the increase of business value on a stock market. As a rule, the strategic business objective is to increase the value of stock capital. In this case an enterprise receives investment resources from stock capital sales.

3. Magnitogorsk Metallurgical Company and Cherepovets Steel Mill should reduce the operation costs (reduce the criterion k_0) and improve the consumer properties of metal sheets (increase the criterion λ). In this case, the conversion criterion and the criterion M will increase.

Conclusions. The mathematical model of operations management has been created based on an operating cycle converting manufacturing capital into monetary capital in the form of produced and sold products and services. The main principle of market economy is realized by this approach. Namely, successful business is determined by the sales value of products and the cost of stock capital on a stock market. These

parameters define the area of a mathematical model in an economic environment.

The criterial Eq. (4) and its vector form (5) including five unit vectors of monetary flows are the integrated set of similarity criteria ensuring the possibility to analyze, design and create conversion operating cycles in manufacturing technological systems with competitive advantages.

The graphical interpretation of a conversion operating cycle has been created in the form of two contours of closed right-angled triangles consisting of five unit vectors of monetary flows. The research of conversion operating cycles allows to conclude that the change of one of five criteria alters all the parameters. This fact is clearly illustrated by the graphical model of the conversion operating cycle. All five similarity criteria participate in the operating cycle simultaneously. It is not possible to improve the conversion operating cycle based on one or two parameters.

The analysis of the criterial equation demonstrates that the conversion criterion is the sum of conversion of manufacturing technological system and business marketing. The conversion criteria of business cannot be more than the conversion criteria of marketing business; they should be equal. The conversion criterion of a real operating cycle depends only on physical fundamentals of a technological process. For example, the conversion criterial of turning technological processing with the material utilization coefficient equal to 0.5 might be increased only by a breakthrough innovation based on replacing it by a technological process with a higher material utilization coefficient.

The manufacturing-technological system of each technological stage should be adjusted to the conversion criterion of the whole system, and in each stage $k_0 \geq M$. In this case, intangible assets appear in the main funds of the enterprise. The balance cost of intangible assets is determined on the basis of the criterial equation.

The directions of further research

Further research will be directed at expanding the areas of this approach in the assessment of innovative activity, such as:

- a) using the theory of similarity criteria in the assessment of business activity;
- b) the ways of improving the design methods in management accounting;
- c) formulating the performance tasks for innovative projects in operations management.

REFERENCES

- [1] **I.L. Tukkel**, Innovation process management, St. Petersburg State Polytechnical University Journal. Economics, 4–2(183) (2013) 13–20.
- [2] **I.L. Tukkel, N.A. Tsvetkova**, O fizicheskikh modelyakh protsessov rasprostraneniya innovatsiy v sotsialno-ekonomicheskoy srede [About physical models of the processes of diffusion of innovation in the socio-economic environment], Innovatsii, (11) (2015) 30–34.
- [3] **J. Tidd**, Open Innovation Research, Management and Practice. Imperial College Press, 2014. 445 p.
- [4] **C.W. Wessner**, National Research Council (U.S.). Committee on Capitalizing on Science, Technology, and Innovation: An Assessment of the Small Business Innovation Research Program-2004. URL: http://www.6cp.net/downloads/03vancouver_wessner.ppt (accessed February 20, 2017).
- [5] **B. Mercan, D. Goktas**, Components of Innovation Ecosystems: a Cross-Country, Study. International Research Journal of Finance and Economics, (76) (2011).
- [6] **B. Meyer**, Agile!: The Good, the Hype and the Ugly. Springer Science & Business Media (2014) 1–170. DOI: 10.1007/978-3-319-05155-0
- [7] **B.-Ye. Lundvall**, National Systems of Innovation. Towards a Theory of Innovation and Interactive Learning, Anthem Press, London, 2010.
- [8] **E.L. Wohldmann, A.F. Healy, Jr.L.E. Bourne**, A mental practice superiority effect: Less retroactive interference and more transfer than physical practice, Journal of Experimental Psychology: Learning, Memory, and Cognition, (34) (2008).
- [9] **M. Peltoniemi**, Cluster, Value Network and Business Ecosystem: Knowledge and Innovation Approach. Paper Presented at «Organisations, Innovation and Complexity: New Perspectives on the Knowledge Economy» conference, September 9–10, in Manchester, UK.
- [10] **A.A. Akayev**, Matematicheskiye osnovy innovatsionno-tsiklicheskoy teorii ekonomicheskogo razvitiya Shumpetera-Kondratyeva [Mathematical foundations of innovative-cyclical theory of economic development Schumpeter-Kondratieff], Almanakh «Kondratyevskiy volny. Aspekty i perspektivy», Uchitel, Volgograd, 2012.
- [11] **V.A. Sadovnichiy, A.A. Akayev, A.V. Korotayev, S.Yu. Malkov**, Modelirovaniye i prognozirovaniye mirovoy dinamiki [Modelling and forecasting world dynamics], Nauchnyy sovet po Programme fund. issled. Prezidiuma Rossiyskoy akademii nauk «Ekonomika i sotsiologiya znaniya», ISPI RAN, Moscow, 2012.
- [12] **I.M. Bortnik, A.V. Sorokina**, Rekomendatsii regionam AIRR po rezultatam reytingovaniya innovatsionnykh regionov [Recommendations to the regions on the results of the rating of innovative regions], Innovatsii, (7) (2014) 59–68.
- [13] Globalnaya transformatsiya innovatsionnykh sistem [Global transformation of innovation systems]. Pod red. N. I. Ivanovoy, IMEMO RAN, Moscow, 2010.
- [14] **V.V. Glukhov, G.F. Detter, I.L. Tukkel**, Sozdaniye regionalnoy innovatsionnoy sistemy v usloviyakh Arkticheskoy zony Rossiyskoy Federatsii: proyektirovaniye i opyt realizatsii [The creation of a regional innovation system in the Arctic zone of the Russian Federation: design and implementation experience], Innovatsii, (5) (2015) 86–98.
- [15] **G.F. Detter**, O printsipakh proyektirovaniya regionalnykh innovatsionnykh ekosistem [On the principles for the design of regional innovation ecosystems], Innovatsii, (1) (2016) 70–79.
- [16] **K.L. Zhikharev**, Soderzhaniye i sushchnost kontseptsii regionalnoy innovatsionnoy sistemy [The contents and essence of the concept of regional innovation system]. URL: <http://www.e-rej.ru/Articles/2011/Zhikharev210.pdf> (accessed February 20, 2017).
- [17] **A.V. Zarkovich**, Teorii innovatsionnogo razvitiya: kontseptsiya regionalnykh innovatsionnykh sistem [Theories of innovation development: concept of regional innovation systems], Gumanitarnyye nauchnyye issledovaniya, (6) (2013) 35. URL: <http://human.snauka.ru/2013/06/3404> (accessed February 20, 2017).
- [18] **V.V. Ivanov**, Innovatsionnaya paradigma XXI [Innovative paradigm XXI], Nauka, Moscow, 2011.
- [19] **V.A. Kosteyev, A.V. Akinshina**, Spetsialist po upravleniyu innovatsiyami v kompanii: spetsifika professii [Specialist in innovation management in the company: specifics of the profession], Innovatsii, (11) (2015) 79–85.
- [20] **A.K. Kochiyeva**, Transfer tekhnologiy i malye innovatsionnyye predpriyatiya kak sostavlyayushchiye innovatsionnogo razvitiya Krasnodarskogo kraya [Technology transfer and small innovative businesses as components of innovative development of Krasnodar region], Innovatsii, (11) (2015) 50–55.
- [21] **V.M. Avramchikov**, Instrumenty upravleniya rasprostraneniym i vzaimodeystviyem voln innovatsiy [Management tools the dissemination and interaction of waves of innovation], Innovatsionnyy vestnik regiona, (1) (2014) 12–17.
- [22] **A.N. Shichkov**, Teoriya i praktika inzhenernogo biznesa i menedzhmenta [Theory and practice of engineering business and management], VoGU, Vologda, 2016. 131 p.
- [23] **A.N. Shichkov**, Designing manufacturing-technological systems, Scientific Israel-Technological Advantages, 18(1) (2016) 89–106.
- [24] **A.N. Shichkov**, Innovative Enhancement of an Engineering Business: Operating cycle Method, Scientific Israel-Technological Advantages, 18 (4) (2016) 100–111.

Shichkov A.N. E-mail: shichkov-an@yandex.ru

СПИСОК ЛИТЕРАТУРЫ

- [1] **Туккель И.Л.** О проблемах управления инновационными процессами // Научно-технические ведомости СПбГПУ. Экономические науки. 2013. № 4-2 (183). С. 13–20.
- [2] **Туккель И.Л., Цветкова Н.А.** О физических моделях процессов распространения инноваций в социально-экономической среде // Инновации. 2015. № 11. С. 30–34.
- [3] **Tidd J.** Open Innovation Research, Management and Practice. Imperial College Press, 2014. 445 p.
- [4] **Wessner C.W.** National Research Council (U.S.). Committee on Capitalizing on Science, Technology, and Innovation: An Assessment of the Small Business Innovation Research Program-2004. URL: http://www.bcp.net/downloads/03vancouver_wessner.ppt (accessed February 20, 2017).
- [5] **Mercan B., Goktas D.** Components of Innovation Ecosystems: a Cross-Country Study. International Research Journal of Finance and Economics, 2011. no. 76.
- [6] **Meyer B.** Agile!: The Good, the Hype and the Ugly. Springer Science & Business Media, 2014. Pp. 1–170. DOI: 10.1007/978-3-319-05155-0
- [7] **Lundvall B.-E.** National Systems of Innovation. Towards a Theory of Innovation and Interactive Learning. London: Anthem Press, 2010.
- [8] **Wohldmann E.L., Healy A.F., Bourne Jr.L.E.** A mental practice superiority effect: Less retroactive interference and more transfer than physical practice // Journal of Experimental Psychology: Learning, Memory, and Cognition. 2008. No. 34.
- [9] **Peltoniemi M.** Cluster, Value Network and Business Ecosystem: Knowledge and Innovation Approach. Paper Presented at «Organisations, Innovation and Complexity: New Perspectives on the Knowledge Economy» conference, September 9–10, in Manchester, UK.
- [10] **Акаев А.А.** Математические основы инновационно-циклической теории экономического развития Шумпетера-Кондратьева // Альманах «Кондратьевские волны. Аспекты и перспективы». Волгоград: Учитель, 2012.
- [11] **Садовничий В.А., Акаев А.А., Коротаев А.В., Малков С.Ю.** Моделирование и прогнозирование мировой динамики // Научный совет по Программе фонд. исслед. Президиума Российской академии наук «Экономика и социология знания». М.: ИСПИ РАН, 2012.
- [12] **Бортник И.М., Сорокина А.В.** Рекомендации регионам АИРР по результатам рейтингования инновационных регионов // Инновации. 2014. № 7. С. 59–68.
- [13] Глобальная трансформация инновационных систем / под ред. Н.И. Ивановой. М.: ИМЭМО РАН, 2010.
- [14] **Глухов В.В., Деттер Г.Ф., Туккель И.Л.** Создание региональной инновационной системы в условиях Арктической зоны Российской Федерации: проектирование и опыт реализации // Инновации. 2015. № 5. С. 86–98.
- [15] **Деттер Г.Ф.** О принципах проектирования региональных инновационных экосистем // Инновации. 2016. № 1. С. 70–79.
- [16] **Жихарев К.Л.** Содержание и сущность концепции региональной инновационной системы. URL: <http://www.e-rej.ru/Articles/2011/Zhiharev210.pdf> (режим доступа: 20.02.2017).
- [17] **Заркович А.В.** Теории инновационного развития: концепция региональных инновационных систем // Гуманитарные научные исследования. 2013. № 6. С. 35. URL: <http://human.snauka.ru/2013/06/3404> (режим доступа: 20.02.2017).
- [18] **Иванов В.В.** Инновационная парадигма XXI. М.: Наука, 2011.
- [19] **Костеев В.А., Акиншина А.В.** Специалист по управлению инновациями в компании: специфика профессии // Инновации. 2015. № 11. С. 79–85.
- [20] **Кочиева А.К.** Трансфер технологий и малые инновационные предприятия как составляющие инновационного развития Краснодарского края // Инновации. 2015. № 11. С. 50–55.
- [21] **Аврамчиков В.М.** Инструменты управления распространением и взаимодействием волн инноваций // Инновационный вестник региона. 2014. № 1. С. 12–17.
- [22] **Шичков А.Н.** Теория и практика инженерного бизнеса и менеджмента. Вологда: ВоГУ, 2016. 131 с.
- [23] **Shichkov A.N.** Designing manufacturing-technological systems // Scientific Israel-Technological Advantages. 2016. No. 18(1). Pp. 89–106.
- [24] **Shichkov A.N.** Innovative Enhancement of an Engineering Business: Operating cycle Method // Scientific Israel-Technological Advantages. 2016. No. 18(4). Pp. 100–111.

Шичков А.Н. E-mail: shichkov-an@yandex.ru

Статья поступила в редакцию 07.02.17

DOI: 10.18721/JE.10206
UDC 65.012.123

DEVELOPING THE MECHANISM OF QUALITATIVE RISK ASSESSMENT IN STRATEGIC CONTROLLING

S.V. Grishunin

Peter the Great Saint-Petersburg Polytechnic University, St. Petersburg, Russian Federation

A mechanism has been developed for assessing a company's strategic risks and selecting the risk factors on which the risk management actions of the company must be focused. The risk factors are projections of the company's internal and external environment which create its competitive advantages but are exposed to the most dangerous threats. The mechanism is an integral part of strategic risk controlling, the application of strategic controlling to risk management, and was built as a set of interrelated procedures which perform the selection of risk factors. The design of the mechanism is based on the integration of strategic analysis of the company's value chain and failure mode and effects analysis (FMEA). This design, unlike that of the alternatives, allows maximum accounting for the majority of links and correlations among strategic goals, projections and risks. The paper elaborates on the main tasks and functions of strategic risk controlling and shows the advantages of integration of value chain analysis and FMEA in a single risk assessment mechanism. It works out the flow chart of the mechanism of assessment of the company's strategic risks. It develops the procedure of calculation of FMEA's risk scores (risk priority numbers (RPNs)) for individual end-risks; at the level of each strategic perspective and at the level of the entire strategy. It develops the procedure of selecting the optimal strategy among the strategic alternatives using the Hurwicz minimax criterion in which strategy-level PRNs are utilized as the measures of risks. Finally, the paper works out the procedure for choosing the risk factors among strategic perspectives and develops the key tool of this procedure, the risk-factor positioning matrix. This matrix allows searching for the optimal ways and tools of risk control. The mechanism allows increasing the efficiency of risk management in strategic controlling and concentrating the management's attention on the company's strategic factors which are exposed to the most dangerous risks.

Keywords: risk management; strategic controlling; risk controlling; analysis of company value chain; failure mode and effects analysis (FMEA); strategic risk assessment

Citation: S.V. Grishunin, Developing the mechanism of qualitative risk assessment in strategic controlling St. Petersburg State Polytechnical University Journal. Economics, 10 (2) (2017) 64–74. DOI: 10.18721/JE.10206

РАЗРАБОТКА МЕХАНИЗМА КАЧЕСТВЕННОЙ ОЦЕНКИ РИСКОВ В СТРАТЕГИЧЕСКОМ КОНТРОЛЛИНГЕ

С.В. Гришунин

Санкт-Петербургский политехнический университет Петра Великого,
Санкт-Петербург, Российская Федерация

Разработан механизм оценки стратегических рисков компании и отбора факторов риска, на которых должны быть сосредоточены основные усилия по управлению рисками в компании. Под факторами рисками понимаются проекции внешней и внутренней среды компании, которые создают ее конкурентное преимущество, но при этом подвергаются наиболее опасным угрозам. Механизм является неотъемлемой частью стратегического риск-контроллинга, приложения стратегического кон-

троллинга к управлению рисками и представляет собой набор взаимосвязанных методик, обеспечивающих пошаговый отбор факторов риска. Он построен с помощью интеграции метода стратегического анализа цепочки ценностей компании и метода анализа видов и последствий отказов (FMEA). Такой подход, в отличие от альтернатив, позволяет максимально учесть связи и корреляции между стратегическими целями, проекциями и рисками. Рассмотрены основные задачи и функции стратегического риск-контроллинга в компании, а также исследованы методы анализа цепочки ценностей и FMEA и обоснованы преимущества их интеграции в едином механизме оценки рисков. Подготовлена блок-схема механизма оценки стратегических рисков компании и отбора факторов риска. В ходе разработки механизма выработана методика расчёта показателей критичности проявления рисков (ПЧР) как для отдельных рисков, так и на уровне каждой стратегической проекции, а также стратегии в целом. Предложена методика выбора базовой стратегии из имеющихся альтернатив с помощью критерия пессимизма – оптимизма Гурвица, в котором в качестве меры риска используются ПЧР. Разработана методика отбора факторов риска и её ключевой инструмент – матрица позиционирования факторов риска, которая также позволяет определить оптимальные способы и инструменты контроля над рисками. Механизм позволяет повысить результативность управления рисками в стратегическом контроллинге и сконцентрировать внимание руководства компании на ее стратегических проекциях, подверженных наиболее опасным угрозам.

Ключевые слова: управление рисками; стратегический контроллинг; риск-контроллинг; метод анализа видов и последствий потенциальных дефектов (FMEA); метод анализа цепочек ценностей; оценка стратегических рисков

Ссылка при цитировании: Гришунин С.В. Разработка механизма качественной оценки рисков в стратегическом контроллинге // Научно-технические ведомости СПбГПУ. Экономические науки. 2017. Т. 10. № 2. С. 64–74. DOI: 10.18721/JE.10206

Introduction. Improving the framework and tools of strategic risk management (SRM) is a problem of today's primary importance. This is due to the growth of uncertainty, dynamics and turbulence of the business environment [1, 6, 21]. The review of literature [2, 6, 7, 9, 16, 21] shows that the effectiveness of SRM can be significantly enhanced if the management focuses only on those factors of competitiveness (FCs) which are the exposed to the most dangerous threats (these FCs are called risk factors (FRs)). One of the most efficient approaches to selecting FRs is to apply the mechanisms integrating the methods of strategic analysis and the methods of risk assessment from engineering science (e.g., failure mode and effects analysis (FMEA)) [2, 15, 20]. For example, in [9], Sutrisno et al. developed a mechanism which integrated strength, weaknesses, opportunities and threats analysis (SWOT) and FMEA. However, it has a number of issues: it is static, it does not account for the correlation between the strategic goals and FRs and, more importantly, it does not segregate the factors of success or failure from the basic conditions of competitiveness. At the same time, the analysis of Russian literature revealed that even though there were a large number of papers on SRM [15], only few of them applied the

integrated mechanisms described above. Consequently, these few studies concentrated on very narrow fields, e.g., assessment of risks in research and development of new equipment, quality management or qualitative risk assessment of small investment projects [3–5, 15, 20].

The scope of the paper. The goal of this paper is to develop a mechanism for assessing a company's strategic risks and for selecting the FRs on which SRM's activities will be focused. The risk assessment with the mechanism is qualitative because it is performed with application of a discrete ordinary scale with 10 grades (see discussion below).

The mechanism integrates strategic analysis of the company's value chain (VC) and FMEA and is an integral part of the company's process of primary strategic risk analysis. It is applied in strategic risk controlling (SRC) which is the application of methods of strategic controlling to SRM [21]. The advantages of SRC over «conventional» SRM are listed in [13]. Among them, the most important advantages are flexibility and efficiency. The suggested mechanism enhances these qualities because it helps optimizing the usage of the company's management resources.

Table 1

FMEA rating scale

Scale	Severity of losses (Y)	Probability of occurrence (P)	Probability of detection (C)
1	None	Remote: failure is unlikely	Almost certain
2	Very minor	Low: very few failures	Very high
3	Minor	Low: relatively few failures	High
4	Very low	Moderately low: infrequent failures	Moderately high
5	Low	Moderate: occasional failures	Moderate
6	Moderate	Moderately high: frequent failures	Low
7	High	High: failures occur often	Very low
8	Very high	Very high: repeated failures	Remote
9	Extremely high	Extremely high: failures occur almost as often as not	Very remote
10	Dangerously high	Dangerously high: failure is inevitable	Absolute uncertainty

The company's VC is the synergetic sum of all of the company's FCs; the primary purpose of VC is to create competitive advantages for the company [2, 21]. By FCs we understand the important and interrelated business operations (both internal and external) which, taken as a system, create the products with the value for the customers [21]. After performing the strategic analysis of VC and relationships among them, the managers understand which FCs contribute to the company's success, which FCs are in line with those of the competitors; and which FCs are the source of the company's strategic weaknesses [14]. In turn, FMEA is a method of qualitative analysis aimed at early detection and assessment of causes and effects of risks. It is also applied as a tool for risk remediation planning in complex systems [2]. By using FMEA, managers can (1) identify the end-risks in FCs and their causes; (2) evaluate the potential losses from these risks; (3) assess if the company's control systems are able to timely detect these risks; and (4) select the FRs to focus on. In FMEA, the criticality of risks is assessed by the risk priority numbers (RPNs). In turn, each RPN is a multiplication of three sub-ratings: the severity of potential losses from the risk (Y); the probability of the risk's occurrence (P); and the probability of early detection of the risk (C (Tab. 1).

We worked out a flow chart of the mechanism (Fig. 1). It shows that the mechanism is an

inherent part of the company's business process of primary analysis of its strategic risks. It consists of the following key steps (highlighted in the flow chart): (1) analysis of the company's value chain and selection of strategic perspectives defining the company's strategic success or failure; (2) identification of end risks and their assessment with FMEA; (3) selection of the master strategy from the alternatives; and (4) selection of risk factors from strategic perspectives on which the activities in SRC will be focused on.

The inputs of the mechanism are alternative strategies of the company [10, 11] which are documented in the company's strategic plan. The key elements of the plan are:

a) The main strategic goal of the company (MSG). This goal describes the company's future in the best possible way. To measure the level of achievement of the MSG, a special control indicator is developed, the indicator of main strategic goal (SGI); for example, the economic value added [6] or the net present value of incremental cash flows [21];

b) Strategic goals (SGs) of FCs which are necessary to achieve the MSG. To measure the achievement of each SG, the sets of control indicators (CIs) are developed [21];

c) The targets for SGs and detailed plans of achievement of each SG;

d) The strategic map. This is a diagram documenting the complete system of SGs, FCs, CIs and the relationships between them [21].

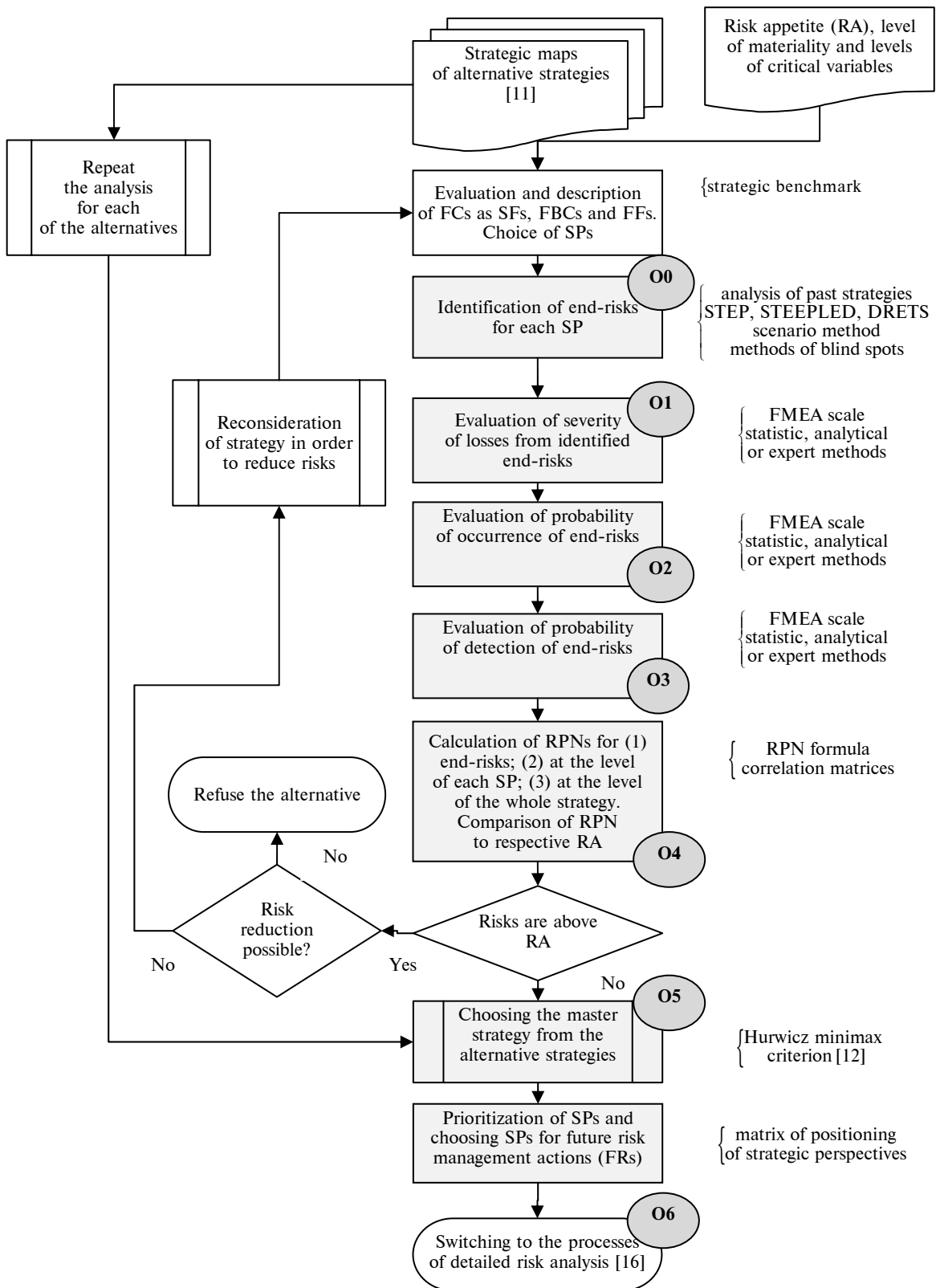

Fig 1. Flow chart of the mechanism of assessment of the company's strategic risks and selection of risk factors

The first step of the mechanism (operation O0) is to analyze the company's VC and to classify all FCs on the map as success factors, factors of basic competitiveness and factors of failures. Factors of success are the key drivers of the company's competitive advantage. Factors of basic competitiveness are the FCs whose levels of maturity coincide with those of the company's peers and sufficient to maintain the company's competitiveness against peers. Factors of failure are the company's weak links and/or the bottlenecks which likely to be the source of the company's future troubles. The company's management focus must be on factors of success and factors of failure (we called these FCs strategic perspectives (SPs) because these FCs determine the company's ability to withstand the competition in long-term perspective. Consequently, the operating risk controlling (ORC), the operating arm of risk controlling, should focus on factors of basic competitiveness because they determine the company's competitiveness on a day-to-day basis [21]. The above classification is performed by methods of strategic benchmarking [21]. The second step of the mechanism is to identify the end-risks which can preclude the company from achieving its strategic goals. At this step, the full list of the end-risks impacting the SPs should be developed. To identify the risks of external environment, strategic analysis methods such as STEP, STEEPLED or DRETS [10, 21], as well as the method of blind spots are applied. Conversely, to identify the internal end-risks, business process analysis is applied [10, 21].

The next four steps of the mechanism consist of qualitative assessment of the end-risks by using FMEA (operations O1-O4). The results of this assessment are passed to the seventh step at which the managers select the master strategy out of strategic alternatives [10] (operation O5). Finally, the managers evaluate the FCs of the master strategy, select FRs (operation O6) and identify the framework and tools of the risk control and detection system.

Application of FMEA to assess the end-risks.

The incoming information for these steps is:

- a) The strategic plan and the list of SPs chosen at step O0;
- b) The set of end-risks emerging at the level of each SP, $R = \{r_{ij}\}$, i is the number of the SP,

$I = 1, N$; j is the number of the end-risk; and the sets of CIs which are impacted by risks from the set R . The sets of CIs form vectors X_{ij} ;

c) The critical variance of SGI from the target set in the strategic plan V^{cr} . Exceeding this critical value means the failure of the strategy;

d) The minimal possible variance of SGI from the target (V^{min}). If the variance is below V^{min} than it is considered non-material.

To perform all the procedures in the mechanism, the team of the company's experts and specialists (the expert team) is formed. Initially, the team defines and approves: (1) the policies and procedures for decision making and communication both inside the team and between the team and decision makers (DMs); (2) the sources of information for analysis; and (3) methods of risk assessment (e.g., statistic, analytical or expert methods) [16, 18, 20].

The evaluation of severity of losses (procedure O1). In the current setting, by the severity of losses we understand the variance of CIs and SGI from the strategic targets. The expert team, in co-operation with the strategic management teams, using the selected method of risk assessment, estimates the variances of CIs in case of occurrence of r_{ij} . These variances form the vectors of CI variances, VX_{ij} . By using VX_{ij} , the team estimates the expected variance of SGI from the strategic target as a result of occurrence of each risk r_{ij} .

$$V_{ij}^r = SG_{ij} - SG_f. \quad (1)$$

V_{ij}^r is the expected variance of SGI from the target

SG_{ij} is the expected value of SGI as a result of occurrence of r_{ij} .

SG_f is the target value of SGI.

Then the V_{ij}^r value is correlated with the ranking of the deviation significance by the FMEA scale (Tab. 1). The same analysis is repeated for all r_{ij} and all SPs.

$$Y_{ij} = \begin{cases} 1 & \text{if } V_{ij}^r \leq V^{min}, \\ \left(\frac{V_{ij}^r - V^{min}}{V^{cr} - V^{min}} \right) 10, & \\ 10 & \text{if } V_{ij}^r \geq V^{cr}. \end{cases} \quad (2)$$

Assessment of the probabilities of the occurrence of individual risks (operation O2). The expert team, in co-operation with the company's strategic planning units, assesses the probability (p_{ij}) of occurrence of each risk r_{ij} by using the selected method of analysis. In case of applying statistical methods of data analysis, the team uses the ratio of frequency of failures to the size of the sample [21]. For new and/or emerging risks (for which the data do not exist or are unreliable), expert methods can be applied. Examples of such methods include: the additive multiplication model developed by Orlov [15, 19] or modifications of the Elmerly method [10]. After the expert team assesses p_{ij} , it determines the corresponding rating of the probability of occurrence by using formula 3 and the FMEA scale (Tab. 1). This analysis is repeated for all risks r_{ij} in all strategic perspectives.

$$P_{ij} = \begin{cases} 1, & \text{if } p_{ij} \in [0; 0.1), \\ p_{ij} \cdot 10, & \text{if } p_{ij} \in [0.1; 0.9], \\ 10, & \text{if } p_{ij} \in (0.9; 1]. \end{cases} \quad (3)$$

Assessment of probability of risk detection at the level of SP (operation O3). The probability of risk detection is a complex rating:

$$c_{ij} = c_{ij}^1 \cdot c_{ij}^2. \quad (4)$$

c_{ij} is the probability of detection of risk r_{ij}

c_{ij}^1 is the probability of early detection of risk by existing control tools;

c_{ij}^2 is the adjusting coefficient taking into account the cost of detection system.

By early risk detection we understand that the time period between the moment of detection of the first signals about the risk's occurrence and the end of the risk's remediation must not exceed the time period during which the risk is fully realized. In the opposite case $c_{ij}^1 = 0$. To evaluate c_{ij}^1 , if past empirical data is sufficient, the expert team can use the ratio of the frequency of prevented risks to the total number of risks occurred. However, if the risk is new or emerging and empirical data are not reliable, then c_{ij}^1 can be assessed by expert methods and/or with the analogy method. In turn, we suggest using the indicator of the risk detection capability of the company's control

system as a proxy for the adjusting coefficient c_{ij}^2 . The detailed formula and an example of calculating this coefficient are presented in [21].

After the expert team assesses c_{ij} , it identifies the corresponding rating of the probability of risk detection (by the FMEA scale (Tab. 1)). Formula (5) is applied:

$$C_{ij} = \begin{cases} 1, & \text{if } (1 - c_{ij}) \in [0; 0.1), \\ c_{ij} \cdot 10, & \text{if } (1 - c_{ij}) \in [0.1; 0.9], \\ 10, & \text{if } (1 - c_{ij}) \in (0.9; 1]. \end{cases} \quad (5)$$

The same analysis is repeated for all risks r_{ij} in all strategic perspectives.

Calculation of risk priority numbers at different levels of the company operation O4). The RPN for each risks r_{ij} (RPN_{ij}) is calculated by the following expression:

$$RPN_{ij} = Y_{ij} \cdot P_{ij} \cdot C_{ij}. \quad (6)$$

The expert team determines and approves with the DMs the following boundaries: (1) the materiality level RPN_{ij}^{min} below which the risk r_{ij} can be considered non-material; and (2) the risk appetite RPN_{ij}^{ra} , describing the maximum quantity of risk r_{ij} which the company is ready to accept. The DMs can decide to set unified levels of materiality and risk appetite for all risks from the set R. In this case, the expert team operates by only two boundaries: RPN^{min} and RPN^{ra} .

To calculate the consolidated RPNs at the level of each SP, the correlation between the risks from the set R should be considered. We recommend to estimate these correlations by using the expert methods [9]. However, it is possible to apply the statistic methods in this case if the company has the sufficient pool of data to evaluate these correlations [15]. Let us define the matrix of pair correlation between the risks at the level of strategic perspective with the number i.

$$\widehat{A}_i = \begin{pmatrix} a_{11}^i & \cdots & a_{1M}^i \\ \vdots & \ddots & \vdots \\ a_{M1}^i & \cdots & a_{MM}^i \end{pmatrix} \quad (7)$$

a_{jm}^i is the pair correlation coefficient between risks j ($j \in [1, M]$) and m ($m \in [1, M]$)

$a_{jm}^i = \mp 0.3$ if weak positive or negative correlation exists between risks j and m;
 $a_{jm}^i = \mp 0.6$ if medium positive or negative correlation exists between risks j and m;
 $a_{jm}^i = \mp 0.9$ if strong positive or negative correlation exists between risks j and m;
 $a_{jm}^i = 0$ if there is no correlation between risks j and m

Let us denote $\widehat{PN}_i = \begin{pmatrix} RPN_{i1} \\ RPN_{i2} \\ \dots \\ RPN_{iM} \end{pmatrix}$ as a vector of

RPNs for the risks r_{ij} at the level of SP with the number i. The consolidated RPN at the level of SP with the number i (RPN_i) equals:

$$RPN_i = \widehat{PN}_i \widehat{A}_i. \quad (8)$$

The materiality level and the risk appetite at the level of SP with the number i are calculated by using the following expressions:

$$RPN_i^{min} = \widehat{PN}_i^{min} \widehat{A}_i; \widehat{PN}_i^{min} = \begin{pmatrix} RPN_{i1}^{min} \\ RPN_{i2}^{min} \\ \dots \\ RPN_{iM}^{min} \end{pmatrix}; \quad (9)$$

$$RPN_i^{ra} = \widehat{PN}_i^{ra} \widehat{A}_i; \widehat{PN}_i^{ra} = \begin{pmatrix} RPN_{i1}^{ra} \\ RPN_{i2}^{ra} \\ \dots \\ RPN_{iM}^{ra} \end{pmatrix}. \quad (10)$$

To calculate the RPN for the strategic alternative as a whole, we define the matrix of pair correlation between the SPs. The same rules as in (7) are applied to define the correlation coefficients b_{ij}

$$\widehat{B} = \begin{pmatrix} b_{11} & \dots & b_{1L} \\ \vdots & \ddots & \vdots \\ b_{L1} & \dots & b_{LL} \end{pmatrix}. \quad (11)$$

The RPN at the level of the strategic alternative is calculated by using the following formulas:

$$\widehat{TPN} = \begin{pmatrix} RPN_1 \\ RPN_2 \\ \dots \\ RPN_N \end{pmatrix}; RPN = \widehat{TPN} \widehat{B}; \quad (12)$$

$$RPN^{min} = \widehat{TPN}^{min} \widehat{B}; \widehat{TPN}^{min} = \begin{pmatrix} RPN_1^{min} \\ RPN_2^{min} \\ \dots \\ RPN_N^{min} \end{pmatrix}; \quad (13)$$

$$RPN^{ra} = \widehat{TPN}^{ra} \widehat{B}; \widehat{TPN}^{ra} = \begin{pmatrix} RPN_1^{ra} \\ RPN_2^{ra} \\ \dots \\ RPN_N^{ra} \end{pmatrix}. \quad (14)$$

To estimate the risk exposures of each strategic alternative, the members of the expert team compare the strategic alternative's RPN with the risk appetite RPN^{ra} . If $RPN < RPN^{ra}$, then the strategic alternative is qualified in the list from which the master strategy will be then selected. If $RPN > RPN^{ra}$ than this strategic alternative is either rejected or returned for reworking in the strategic planning department. If $RPN < RPN^{ra}$, but the strategic alternative contains one or several SPs for which $RPN_{ij} > RPN_{ij}^{ra}$, the following options are possible: (1) to accept this strategy for further consideration but, if it were selected as a master strategy, to develop and implement for it the reinforced methods of control in those SPs where $RPN_{ij} > RPN_{ij}^{ra}$; or (2) to return the strategy for reworking.

The sixth step of the mechanism is to select the master strategy from the set of strategic alternatives. We suggest using the Hurwicz minimax [12] for this purpose. In combination with RPNs for each strategic alternative, this criterion can be written as:

$$\max \{CrG_z\}_{z \in [1, Z]} = \max \left\{ \frac{RPN_z}{1000} SG_z^{press} + \left(1 - \frac{RPN_z}{1000} \right) SG_z^{nr} \right\}_{z \in [1, Z]}. \quad (15)$$

CrG_z is the value of the Hurwicz criterion for the z-th alternative strategy

RPN_z is the risk priority number for the z-th alternative strategy

Z is the total number of analyzed alternative strategies

R_z is the set of end-risks for the strategic alternative z

SG_z^{pess} is the value of SGI for the alternative z , if all the risks are from the set R_z

SG_z^{nr} is the value of SGI in risk-free environment

To choose the master strategy, the expert team, together with the strategic planning unit, develops scenarios and calculates SG_z^{pess} and SG_z^{nr} ; and then calculates CrG_z for each strategic alternative from the set Z . In the next step, the expert team finds the strategic alternative s from Z alternatives with the maximum value of CrG_z . This strategic alternative is presented to the DMs for review and approval as the master strategy.

Selecting the risk factors (FRs) from the SPs of the master strategy (operation O6). At the first step, the expert team, compares RPN_i for each SP_i $i \in [1, N]$ with RPN_i^{min} . If $RPN_i < RPN_i^{min}$, then SP_i is excluded from future consideration. Conversely, SP_i for which $RPN_i > RPN_i^{min}$ should be selected as FR. Let us denote the set of FRs as F . At the second step, the expert team decides upon (1) to split the responsibility for managing each FR from F between operating and strategic risk-controlling (ORS and SRC); (2) to define the framework of the control system over risks for each FR and to choose the most suitable control tools. To assist in solving these tasks, we have developed the matrix of risk factor positioning (Tab. 2). This tool is based on the matrix developed by Lambin [17]. Before working with the matrix, the expert

team subjectively determines the qualitative scale (high or low) of the ratings comprising the RPN (the ratings Y, P and X) for each FR from the set F , and gets it approved by the DMs.

Area 1 is an area of retrospective controls or area of minimal hazard. The probability of risk occurrence in this area is low; for the FRs qualified into this area, only feedback controls of ORC are employed. These controls compare the actual performance of strategic goals to the targets set in the strategic plans after the end of the covered period in order to detect variances.

Area 2 is an area of reduced operating controls. Risks are still low in this area while the ability to control the risks is high. Therefore, for the FRs qualified into this area, it is sufficient to use only two types of ORC controls [21]: (1) preliminary controls (to reveal the potential variances from targets before the business processes in FR have started); and (2) feedback controls.

Area 3 is an area of plausible strategic hypothesis. For the FRs qualified into this area, two types of controls are used. Firstly, they are the preliminary controls from the SRC arsenal and employed for selection of the most plausible strategic scenario [21]. Secondly, they are ORC feedback controls.

Area 4 is an area of full operating control. The probability of risk detection is higher in this area than that in area 3 which implies more through control. For the FRs qualified into this area, we suggest using (a) the SRC preliminary controls; and (b) all types of controls from the ORC arsenal.

Table 2

Matrix of risk factor positioning

№	Value of FMEA components (ratings)			Name of the positioning area	Responsibility
	Y	P	C		
1	low	low	low	Area of retrospective control	ORC
2	low	low	high	Area of reduced operating control	ORC
3	low	high	low	Area of plausible strategic hypothesis	Combination of ORC and SRC
4	low	high	high	Area of full operating control	Combination of ORC and SRC
5	high	low	low	Area of rare dangerous events	SRC
6	high	low	high	Area of reduced strategic control	SRC
7	high	high	low	Area of full strategic control	SRC
8	high	high	high	Area of strategic vulnerability	SRC

Area 5 is a zone of rare hazardous events (or “black swans” [6]). These events can lead to significant deviations from the strategic targets, but are quite rare and come unexpectedly. The possible control strategies for these FRs are [21]: (a) to ensure (transfer) the risks to third parties; (b) to build the reserves to mitigate the potential losses; (c) to use contingency planning; (d) to use the simplified SRC controls (concurrent and signaling); or (e) to localize the business exposed to these risks in the project company.

Area 6 is a zone of reduced strategic control. Unlike area 5, the probability of risk detection is much higher in this area. We suggest using here (a) SRC preliminary controls; (b) SRC controls by weak signals (with the goal to detect the risk probability as precisely as economically possible); and (b) SRC feedback controls. We also suggest using here the same control strategies as those in area 5 (maintenance of reserves, contingency planning, localization of business units, etc.).

Area 7 is an area of full strategic control. Risks in this area are the most dangerous; but the probability of detection of these risks is also high. We suggest employing here all types of controls from the SRC arsenal [21]. Consequently, we suggest considering contingency planning and reserve maintenance.

Lastly, **area 8** is a zone of strategic vulnerability [21]. These FRs are exposed to the most dangerous threats which are almost impossible to detect, but, at the same time, these areas are also the sources of maximum competitive advantages. The main strategies here are to localize such FRs or to transfer the risks. It is possible to use simplified control models by weak signals from the SRC arsenal for the maximum possible reduction of risks [21].

The results of the study. In this paper, we developed a mechanism of assessment of the company’s strategic risks and selection of the risk factors on which the risk management activities should be focused. To build this mechanism, we integrate the method of strategic analysis of the company’s value chain and FMEA. The mechanism is the integral part of the company’s SRC system and it is embedded into the process of primary analysis of the company’s strategic risks. The mechanism is designed as a set of interrelated procedures which provided step-by-step selection of FRs. In particular:

1. We analyzed the possibility of integrating the strategic analysis of VC and FMEA in one mechanism of assessment of the enterprise’s strategic risks and considered the advantages and disadvantages of such integration;

2. We developed the flow chart of the mechanism and described its main steps. These steps include: (1) analysis of the company’s VC to select the SPs which determine the company’s strategic success or failure; (2) identifying the end-risks and performing their qualitative assessment by FMEA; (3) selection of the company’s master strategy among the strategic alternatives; and (4) selection of the FRs from the SPs as well as the identification of the most suitable methods and tools to control the risks in the selected FRs.

While working out the mechanism, we developed the following procedures and instruments:

1. The procedure of calculation of the RPNs and their components for assessment of (a) individual end-risks; (b) consolidated risk exposures at the level of SPs; and (c) consolidated exposures at the level of each strategic alternative;

2. The procedure of the company’s master strategy selection from strategic alternatives. That procedure employed the Hurwicz minimax criterion, in which we used consolidated RPNs of alternative strategies;

3. The procedure of selecting the FRs from the set of SPs. That procedure compared the consolidated RPNs at the level of SPs to the predetermined risk thresholds.

4. The matrix of SP positioning employed for selecting the methods and tools of control over end-risks.

Conclusion. The developed mechanism of assessment of the company’s strategic risks and the selection of risk factors aimed at focusing the risk management activities in the SRC only on those factors of competitiveness of the company which are exposed to the most dangerous threats. The usage of that mechanism would increase the efficiency of risk management and improve the utilization of the company’s management resources. The mechanism integrated the strategic analysis of the company’s value chain and FMEA and, unlike the other approaches such as integration of SWOT and FMEA,

allowed taking into account all correlations and links among strategic goals, strategic risks and factors of competitiveness. Unlike other studies on this topic, which were often very descriptive, we have developed the detailed procedures aimed at (1) assessing the risk exposures of FCs;

(2) selection of the company's master strategy which is balanced between the company's competitive advantages and risks in the best possible way; and (3) selection of the most efficient methods and tools of strategic controls to employ in the selected FRs.

REFERENCES

- [1] **A. Aschebbrucker, P. Horwath, U. Michel**, Controlling in unstable environment, *Kontrolling*, (51) (2014) 22–30.
- [2] **C.S. Carlson**, *Effective FMEAs*. John Wiley & Sons, 2012. 425 p.
- [3] **P.S. Chen, M.T. Wu**, A modified FMEA for supplier selection problems in the supply chain risk environment: a case study, *Computers and Industrial Engineering*, 66(4) (2013) 634–642.
- [4] **W. Gilchrist**, Modelling failure modes and effects analysis, *International Journal of Quality and Reliability Management*, (2) (1993) 16–23.
- [5] **A.G. Frank, D.V.S. de Souza, J.L. Ribeiro, M. Echeveste**, A framework for decision main investment alternatives, *International Journal of Production Research*, 51(19) (2013) 5866–5883.
- [6] **F. Funston, S. Wagner**, Surviving and Thriving in Uncertainty. Creating the Risk Intelligent Enterprise. John Wiley & Sons, 2010. 338 p.
- [7] **M. Kearney, A. Blau, E. Heimbach**, Risk Sensing. The evolving state of art. 2015. URL: www2.deloitte.com/content/dam/Deloitte/us/Documents/risk/us-risk-sensing.pdf (accessed February 07, 2017).
- [8] **H.C. Liu, L. Liu, N. Liu**, Risk evaluation approaches in FMEA: a literature review, *Expert Systems with Applications*, 40(2) (2013) 828–838.
- [9] **A. Sutrisno, H.M. Kwon, I. Gunawan, S. Eldridge, T.R. Lee**, Integrating SWOT analysis into the FMEA methodology to improve corrective action decision making, *Int. Journal Productivity and Quality Management*, 17(1) (2016) 104–126.
- [10] **E.E. Abushova, S.B. Suloeva**, Methods and models of contemporary strategic analysis, *St. Petersburg State Polytechnical University Journal. Economics*, 1(187) (2014) 165–176.
- [11] Implementation of balanced scorecard. Horwath & Partners; Translation from German, Alpina Business Books, Moscow, 2008. 478 p.
- [12] **A.M. Dybov**, Osobennosti otsenki investitsionnykh proektov s uchetom faktorov riska i neopredelennosti [Features evaluation of investment projects taking into account risk factors and uncertainty], *Journal of Udmurtia University*, (2) (2010) 7–14.
- [13] **V.V. Krymskii, A.E. Pankov**, Risk-controlling system of the industrial enterprise, *St. Petersburg State Polytechnical University Journal. Economics*, 2(192) (2014) 114–122.
- [14] **E.N. Kuraeva**, Ispol'zovanie kontseptsii «tsepochki tsennosti» pri sozdanii konkurentnykh preimushchestv kompanii [The use of the concept "value chain" when creating the company's competitive advantages], *Strategic and project management. Digest of articles*. Chief Editor Prudski' V.G., Perm State National Research University, Perm (2011) 181–185.
- [15] **V.V. Miroshnikov, A.A. Filiptchuk**, Application of FMEA methodology for qualitative appraisal of investment project in small and middle enterprises, *Public Administration E-Journal, School of Public Administration Lomonosov Moscow State University*, (28) (2011). URL: http://e-journal.spa.msu.ru/uploads/vestnik/2011/vipusk_28_sentjabr_2011_g./problemi_upravljenija_teorija_i_praktika/miroshnikov_phillipchuk.pdf (accessed October 26, 2016).
- [16] **D.S. Nefedev, S.B. Suloeva**, Model selection of priority business partners the industrial enterprise, *St. Petersburg State Polytechnical University Journal. Economics*, 6–1(185) (2013) 248–257.
- [17] **A.I. Orlov**, The current state of risk controlling, *Polythematic online scientific journal of Kuban State Agrarian University*, 98(04) (2014) 32–64.
- [18] **A.I. Orlov, E.V. Lutsenko, V.I. Loi'ko**, Perspektivnye matematicheskie i instrumental'nye metody kontrollinga [Promising mathematical and instrumental methods of controlling], *Monograph, Kuban State Agrarian University*, 2015. 600 p.
- [19] **A.I. Orlov**, Additive-multiplicative model for risk estimation in the production of rocket and space technics. *Polythematic online scientific journal of Kuban State Agrarian University*, 102 (08) (2014) 78–111.
- [20] **S.K. Rozanova, T.G. Stefanova, K.M. Tumanov**, Metod FMEA (metod analiza vidov i posledstviï otkazov (defektov) analiz riskov i posledstviï [Method the FMEA method (analysis of types and consequences of failures (defects) the risk and impact analysis]. *Sredstva i metody upravleniia kachestvom*, *Monograph, Saint Petersburg State Economics University, St. Petersburg* (2015) 35–38.
- [21] **S.B. Suloeva**, Strategicheskij kontrolling na promyshlennom predpriatii [Strategic controlling at the industrial enterprise], *Monograph, Nestor, St. Petersburg*, 2005. 182 p.

Grishunin S.V. E-mail: sg279sg279@gmail.com

СПИСОК ЛИТЕРАТУРЫ

- [1] **Aschebbrucker A., Horwath P., Michel U.** Контроллинг в нестабильной среде // Контроллинг. 2014. № 51. С. 22–30.
- [2] **Carlson C.S.** Effective FMEAs. John Wiley & Sons, 2012. 425 p.
- [3] **Chen P.S., Wu M.T.** A modified FMEA for supplier selection problems in the supply chain risk environment: a case study // Computers and Industrial Engineering. 2013. Vol. 66. No. 4. Pp. 634–642.
- [4] **Gilchrist W.** Modelling failure modes and effects analysis // International Journal of Quality and Reliability Management. 1993. No 2. Pp. 16–23.
- [5] **Frank A.G., de Souza D.V.S., Ribeiro J.L., Echeveste M.** A framework for decision making in investment alternatives // International Journal of Production Research. 2013. Vol. 51. No. 19. Pp. 5866–5883.
- [6] **Funston F., Wagner S.** Surviving and Thriving in Uncertainty. Creating the Risk Intelligent Enterprise. John Wiley & Sons. 2010. 338 p.
- [7] **Kearney M., Blau A., Heinbach E.** Risk Sensing. The evolving state of art. 2015. URL: www2.deloitte.com/content/dam/Deloitte/us/Documents/risk/us-risk-sensing.pdf (дата обращения: 07.02.2017).
- [8] **Liu H.C., Liu L., Liu N.** Risk evaluation approaches in FMEA: a literature review // Expert Systems with Applications. 2013. Vol. 40. No. 2. Pp. 828–838.
- [9] **Sutrisno A., Kwon H.M., Gunawan I., Eldridge S., Lee T.R.** Integrating SWOT analysis into the FMEA methodology to improve corrective action decision making // Int. Journal Productivity and Quality Management. 2016. Vol. 17. No. 1. Pp. 104–126.
- [10] **Абушова Е.Е., Сулоева С.Б.** Методы и модели современного стратегического анализа // Научно-технические ведомости СПбГПУ. Экономические науки. 2014. № 1(187). С. 165–176.
- [11] Внедрение сбалансированной системы показателей / Horwath & Partners; пер. с нем. М.: Альпина Бизнес Букс, 2008. 478 с.
- [12] **Дыбов А.М.** Особенности оценки инвестиционных проектов с учетом факторов риска и неопределённости // Вестник Удмуртского университета. 2010. № 2. С. 7–14.
- [13] **Крымский В.В., Панков А.Е.** Система риск-контроллинга промышленного предприятия. // Научно-технические ведомости СПбГПУ. Экономические науки. 2014. № 2(192). С. 114–122.
- [14] **Кураева Е.Н.** Использование концепции «цепочки ценностей» при создании конкурентных преимуществ компании // Стратегическое и проектное управление: сб. науч. ст. / гл. ред. В.Г. Прудский; Пермский гос. национальный исследовательский ун-т. Пермь, 2011. С. 181–185.
- [15] **Мирошников В.В., Филипчук А.А.** Применение FMEA-методологии для качественной оценки инвестиционных проектов малого и среднего предпринимательства // Государственное управление. Электронный вестник. 2011. № 28. URL: http://e-journal.spa.msu.ru/uploads/vestnik/2011/vipusk_28_senjabr_2011_g./problemi_upravlenija_teorija_i_praktika/miroshnikov_phillipchuk.pdf (дата обращения: 26.10.2016).
- [16] **Нефедьев Д.С., Сулоева С.Б.** Модель выбора приоритетных деловых партнеров промышленного предприятия // Научно-технические ведомости СПбГПУ. Экономические науки. 2013. № 6–1(185). С. 248–257.
- [17] **Орлов А.И.** Современное состояние контроллинга рисков // Научный журнал КубГАУ. 2014. № 98(04). С. 32–64.
- [18] **Орлов А.И., Луценко Е.В., Лойко В.И.** Перспективные математические и инструментальные методы контроллинга: моногр. Краснодар: КубГАУ, 2015. 600 с.
- [19] **Орлов А.И.** Адаптивно-мультипликативная модель оценки рисков при создании ракетно-космической техники // Научный журнал КубГАУ. 2014. № 102(08). С. 78–111.
- [20] **Розанова С.К., Стефанова Т.Г., Туманов К.М.** Метод FMEA (метод анализа видов и последствий отказов (дефектов) анализ рисков и последствий // Средства и методы управления качеством: моногр. СПб.: Санкт-Петербургский гос. экон. ун-т, 2015. С. 35–38.
- [21] **Сулоева С.Б.** Стратегический контроллинг на промышленном предприятии: моногр. СПб.: Нестор, 2005. 182 с.

Гришунин С.В. E-mail: sg279sg279@gmail.com

Статья поступила в редакцию 20.02.17

DOI: 10.18721/JE.10207

УДК 330.47; 330.46

INFORMATION AND ANALYTICAL COMPONENTS IN MODERN APPLICATIONS

Y.P. Lipuntsov

Lomonosov Moscow State University, Moscow, Russian Federation

The potential of an information system is determined by a combination of the information and economic-mathematical models implemented in it. These models serve as a basis for the information and analytical components. They fulfill various functions: the information component corresponds to the information content and access to data, while the combination of economic-mathematical models of the analytical component determines the intelligence of the data processing. With the development of distributed systems and cloud technologies, the need arises to examine the two components separately. The need to distinguish these two components arises especially acutely in large-scale projects such as the creation of a government infrastructure. Under the conditions of industrial data delivery, when the majority of the participants in an economic activity are acting in the role of producers and consumers of information, standardization of how the data are presented and of the methods of processing them becomes essential. This article handles the two components of an information system as two independent subsystems, the separate stages of creating models are described, and the logic of their interaction in the system is shown. The interrelationship of the components is presented in the form of a reflection of the separate activity logic elements on the information level and further on the program level, as well as the feedback from the applications onto the information and logic of the activity. The description of the components is focused on subject matter experts whose role is growing at the present level of informatization. Most local and simple elements of activity have passed the stage of primary informatization and the task of establishing interaction among the systems and integrating them is becoming urgent. These tasks require a deep understanding of the subject domain in order to embody them in integrational information systems. The training of economic-mathematical and cybernetics specialists is frequently limited by the disciplines of economic-mathematical modeling without proper presentation of these models in information models and applications.

Keywords: information modeling; economic-mathematical modeling; transaction systems; integration systems; methods of data processing; methods of data integration

Citation: Y.P. Lipuntsov, Information and analytical components in modern applications, St. Petersburg State Polytechnical University Journal. Economics, 10 (2) (2017) 75–87. DOI: 10.18721/JE.10207

ИНФОРМАЦИОННАЯ И АНАЛИТИЧЕСКАЯ КОМПОНЕНТА В СОВРЕМЕННЫХ ПРИЛОЖЕНИЯХ

Ю.П. Липунцов

Московский государственный университет им. М.В. Ломоносова,
Москва, Российская Федерация

Потенциал информационной системы определяется совокупностью реализованных в ней информационных и экономико-математических моделей. Эти модели служат основой для информационной и аналитической компонент. Они выполняют

разные функции: информационная компонента отвечает за информационное наполнение, доступность данных, а совокупность экономико-математических моделей аналитической компоненты определяет интеллектуальность обработки данных. С развитием распределенных систем, облачных технологий возникает необходимость рассматривать две компоненты отдельно. Особенно остро необходимость разделения двух компонент возникает в масштабных проектах, таких как создание инфраструктуры электронного правительства. В условиях индустриальной поставки данных, когда большинство участников экономической деятельности выступают в роли производителей и потребителей информации, необходимым становится стандартизация представления данных и методов их обработки. Мы две компоненты информационной системы рассматриваем как две независимые подсистемы с описанием отдельных этапов создания моделей и показом логики их взаимодействия в системе. Соотношение компонент представлено в форме отражения отдельных элементов логики деятельности на информационный и далее на программный слой, а также обратной связи от приложения на информацию и логику деятельности. Описание компонент ориентировано на экспертов предметной области, роль которых на современном уровне информатизации возрастает. Большинство локальных и простых элементов деятельности прошли стадию первичной информатизации, и становится актуальной задача установления взаимодействия между системами, их интеграции. Эти задачи требуют глубокого понимания предметной области для воплощения в интеграционных информационных системах. Зачастую подготовка специалистов экономико-математической, кибернетической направленности ограничивается дисциплинами экономико-математического моделирования без надлежащего представления этих моделей в информационных моделях и приложениях.

Ключевые слова: информационное моделирование; экономико-математическое моделирование; транзакционные системы; интеграционные системы; методы обработки данных; методы интеграции данных

Ссылка при цитировании: Липунцов Ю.П. Информационная и аналитическая компонента в современных приложениях // Научно-технические ведомости СПбГПУ. Экономические науки. 2017. Т. 10. № 2. С. 75–87. DOI: 10.18721/JE.10207

Introduction. With the development of information technologies, economic-mathematical modeling is acquiring additional possibilities for applying models to real data. Data providers have accumulated huge volumes of information in various fields of economic activity. Using economic-mathematical models on real data assumes building applications that process real-time data and historical data supplied.

The analytical and information components are two of the fundamental subsystems of an application which are not often considered separately from each other in the literature. GOST 34 (Rosstandart 1990) provides for separate description of information and mathematical software, but it contains only the most general technological features.

The purpose of this article is to present separately the two components of information systems, information and analytical. In describing the information component, a division of information models into transactional and integrational is presented, and a brief description of each of the categories is given. The analytical

processing section includes a categorization of data processing methods. The final section shows the interaction of the information and analytical components.

The applied aspect of statements described in the article consists of their application in implementing large-scale models and constructing distributed systems such as the model of interagency interaction laid out in the work «An Information Model of Interagency Communication Based on Distributed Data Storage» (Lipuntsov, 2016).

The infrastructure of the electronic government (e-government) assumes creating an information and computer parts of the infrastructure. The complexity and dynamics of automated activity must include solutions of various forms, a large portion of which are found in the distributed environment. Therefore, standardization of methods and models for integration of both data and computer models is required.

Creation of an economic-mathematical model that operates on real data includes three

elements: the economic-mathematical model, the information model, and the application. Each of the three elements has its own levels of abstraction, its own set of models, and interrelationship of abstract with applied models is based on various principles. Several models can be built on each level, in order to describe the system from different points of view and to present its complexity. The levels of abstraction allow to determine the models' boundaries, show their connection, and describe its nature.

An application and information and economic-mathematical models can have different levels of development. One of the variations for presenting a level of development is the V diagram which reflects the sequence of stages in the form of enlarged sections: *decomposition and implementation* of components and *integration* of components into a system. The creation of the information system as a whole as well as its separate elements, the information and the economic-mathematical model, can be described in the form of a V-diagram.

I. The stages in developing an information system. Let us examine the sequence of creating a large-scale information system that unites several lower-level systems. The creation of the system is initiated by a client who has certain expectations. **Decomposition:** the expectations are worked out in detail in the form of requirements; the requirements are the fundamental tasks for creating the components. Contractors create the separate components, which are then integrated into a full-fledged system.

The information system being created will function in the operational environment and have an effect on several communities. The term communities here means teams of specialists working on various levels of management or in contiguous subject domains that fall within the boundaries of the project. Each of the communities forms its own view of the system, attitude and expectations, however, all of the communities will have to interact with regard to that system. Having various views, the communities can use different terms to designate the same objects, or can construe the same terms differently. Therefore, a necessary element in creating an information system is *documentation*, which is accompanied by a schematic reflection of the processes of activity, data collection and

processing, and a description of the services to be implemented. This includes information models on the conceptual and logistical level; the technological solutions and interfaces of the interactions of the components are also determined here. At this stage, the system requirements are transmitted to requirements for its separate components.

After all the details of the components have been determined, the stage of implementation follows. The separate elementary components are created first, and then they are integrated into the system's modules. At the stage of implementation, the logic of real-world activity is embodied in the components of the information system and is implemented in data models or in application code. **Development** of the components of an information system depends, on the one hand, on the data model that has been designated to deliver data; and on the other hand, on the economic-mathematical model. The economic-mathematical models presented in the form of an algorithmic description are converted into data processing procedures. The set of stages for information system processing in the form of a V-diagram is shown in Fig. 1.

Integration of the components in the system requires constant verification and validation. *Verification* compares the components being created with the requirements and standards, while *validation* checks the extent to which the system being created meets the requirements of the end users and corresponds to the extent to which the right system is being created.

Verification of the individual components entails *tracing* the component requirements with technical requirements and tracing the system requirements with the expectations of the end users. This is reflected by the horizontal lines in the diagram. The inclined lines reflect the connection of the system-level requirements with the requirements for separate components, as well as the set of tests that can verify the system and its components.

II. Information models. The basic purpose of the information model is to reflect the subject domain in the data layer. The stages in creating an information model in the shape of a V-diagram are described in (Lipuntsov, 2015). Let us focus here on a brief categorization of information models.

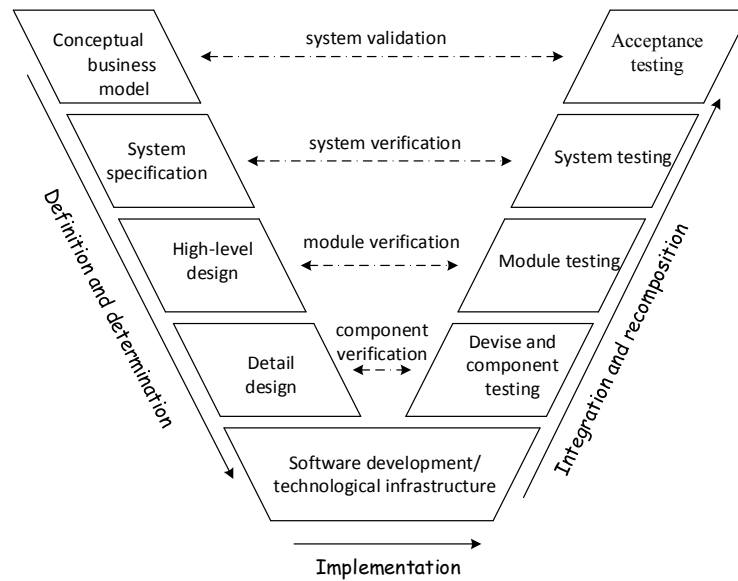

Fig. 1. V-diagram for developing an information system. Source (Shamieh, 2014)

Information models can be divided into two categories based on type: information models of transaction systems, and information models of integration systems. Such a classification corresponds to the following categories of information systems described in (Landon, 1988): transaction information systems (IS), management IS, decision-making support systems, and IS for top management. Elementary actions are fixed in the transactional systems, while data integration and data processing is carried out in higher-level information systems. The higher the level of the system, the more complex are the models for integration and processing.

Information models of data integration. Let us first examine the models for integration, and then we will briefly dwell on the principles for creating models of those transaction systems. The models for data integrating may be roughly divided into two classes: a hypercube, or the Data Vault model (Inmon et al., 2014) which is based on a graph of basic entities and connections between them.

The hypercube consists of a multidimensional generalization of two- and three-dimensional tables for multidimensional data sets, with the presumption that data may have an arbitrary number of dimensions. For example, calculation of financial data in a company is possible by product, time periods, regions, etc. Sales, profit, expenditures, budget, prognosis, and other indicators will appear as cells in the cube. Data in

the hypercube is stored in the form of a star or snowflake network. The values are located in a central table of facts, while a description of various measurements is given in the form of references.

In contrast to the hypercube, the Data Vault allows to store data coming from various local systems with tracking of the history of their changes. This is achieved by a two-level storage structure: on one level the basic components and the connections between them are presented, while data storage is managed on the second level. Such a storage model allows not only to look through current and historical data, but also to ensure expandability of the model and its resistivity.

The ontology of the subject domain is a basis for creating a data model for this type of repository. One of the variants of the methodology for composing the ontology for a data repository of this type is described in the author's work «The Principles of Creating an Ontology for a Data Repository. The Example of 'Higher Education'» (Lipuntsov, 2016). The methodology includes a separation of all entities into primary and derivative. Each of the entities has a content key; the key for the derivative entities is formed as their composition, which allows to create transaction keys in terms of the primary entities.

The information model of a distributed system can be implemented in the form of a federation, in which case a system for exchanging messages of standardized data is implemented in the center. A second variation is organizing a data repository into which data

from local systems are loaded. As a rule, most large-scale corporate systems, such as bank systems, use as data repository variants.

Information models of transactional systems

Let us discuss briefly the information models of transactional systems. Six perspectives can be separated out in the models of these transactional systems (Hay, 2006):

- basic information objects,
- transactions,
- roles,
- time,
- location,
- motive.

Basic information objects and transactions are the most important from the above-mentioned three perspectives in reflecting the activity and subsequent integration of data. The roles represent a transformation of the organizational structure and are intended to provide the authority for working with data in local systems. The space-time extent is presented either in the form of regulatory and reference information, for example in the form of an address system, or in the form of transaction characteristics. The motive is the result of connecting an organization's goals with processing the data of an operational activity.

The separation of perspectives and standardization of the format for presenting basic objects and transactions in transactional systems is an important strand to which attention should be dedicated when developing systems. This will allow to create templates for data models in subject domains and will facilitate integration.

The principle of separating the integrational component from the transactional is important from the perspective of the information model. Most projects for data integration, including those on the governmental level (Fowler J., 1999), use an integration platform for implementing the transactional services of e-government. These two areas are spaced apart in the model according to (Lipuntsov, 2016). The integration platform is intended for gathering data from transactional systems. The platform prepares the data for downloading to the repository, historical or noncurrent data are marked, and all transactions are carried out by external systems. In addition, transactions not implemented in the external systems are reproduced in supplementary applications. The architecture, including the transactional and integrational parts, makes the information model transparent and allows to implement the complex activity logic without any conflicts.

Concluding the description of the information component, it should be noted that efforts should be made within the framework of the information infrastructure of e-government to create an environment that makes it easy to obtain data from various sources of the external environment and integrate them with the native data for joint processing.

Fig. 2 show a conventional operating diagram with the data sets describing the connection of data sets from three sources and the result of integrating them is presented as one combined data set ready for analytical processing. Operations with data used in the IBM Mashup Center v3.0 application were used in Fig. 2.

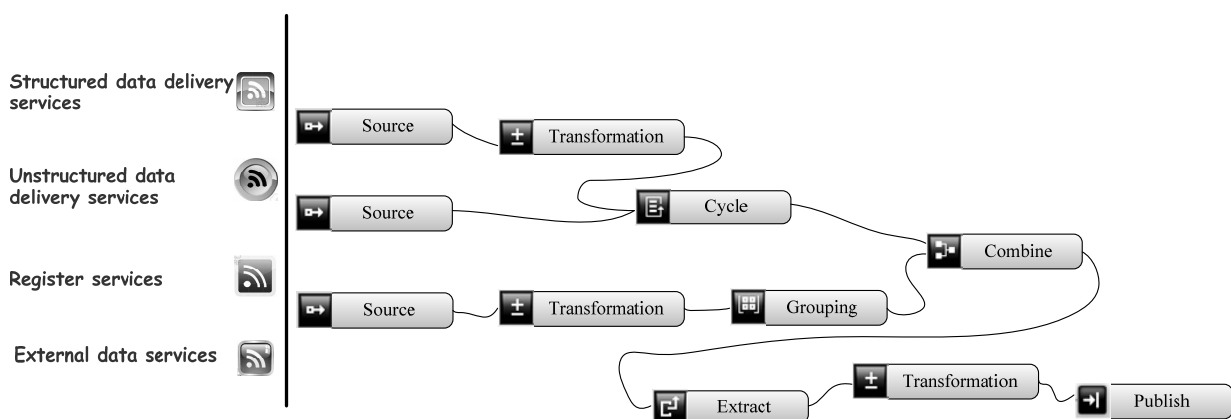

Fig. 2. Diagram of mashup application

III. Economic-mathematical models of analytical components. The ability of an organization to adapt effectively to changes is the key factor in success in the quickly changing economic environment. “Smart software”, with which a company or institution will be able to work out new models of activity, is a tool that allows timely reaction to changes. Development of an analytical component is based on information systems which are developed taking into account the goals of the company or institution.

Let us examine the analytical IS component from this point of view, the creation of which can be considered as a consequence of models of various levels of abstraction from the general systems theory (Mesarovich et al., 1978). In systems theory, the following levels of abstraction are considered: linguistic, theoretical-multiple, abstract-algebraic, topological, logical-mathematical, theoretical-informational, dynamic, and heuristic. The first five model categories describe movement from the general to the particular.

Models of the *linguistic* system level determine the totality of objects under study and the relationship between them, as well as the boundaries of the project. A macroeconomic model at this level of abstraction includes such objects as the government, a firm, household, market of goods and services, financial markets, etc. The relationships among the objects are described by the such terms as income, taxes, consumption, savings, etc. Such models are built both for the macro and micro levels (Gracheva et al., 2013).

The *theoretical-multiple* level of abstraction encompasses the ability to describe the hierarchy of a subject domain. A set of indicators is an example from macroeconomics: gross domestic product, net domestic product, national income, etc. The hierarchy of indicators on the micro level includes concepts such as income – expenses – profit – distribution into dividends, etc.

On the next level of detailing, abstract-algebraic, the system is described through functions, parameters, and other artefacts. Examples of such models are production functions, models of national income distribution by production factors, etc. Apart from the models themselves, the mathematical apparatus of data processing is described. Mathematical models may be considered in the context of the information system developed as a kind of models in which

the legend, the description of the notations and mathematical symbols used represents an informal ontology of the modeled subject domain. In this ontology, the connections determined by the resources of the mathematical language are used. The form in which the ontology is presented is determined by the mathematical modeling apparatus used: linear algebra, differential or integral equations, matrix game theory, linear and nonlinear programming, infinite game theory, and other methods (Allen, 1963), (Carlin, 1964). In addition, econometric methods that study the properties of estimates and tests are used.

Topological models consider the location of economic subjects in space. Examples of topological tasks include models of the “linear city” and the “round city”, i.e., models of spatial differentiation of the market “in a line” and “in a circle”.

Data processing using the mathematical apparatus is considered on the *logical-mathematical level*. Tasks involving financial planning, management of material resources, purchasing, sales, orders from consumers, etc., are solved on the level of enterprises. To implement such tasks, algorithms capable of taking specific problems into account are used (Kogalovskiy, 2002), including the simplex method, transportation tasks, problems from graph theory and network optimization, etc.

The description of the automation functioning including the representation of incoming and outgoing signals, state of the system, and its transition function may be considered one of the variants of the model on this level.

The economic-mathematical model in the form of an algorithmic description is **implemented** in the form of program components at the stage of *theoretical-information models*.

The object approach is often used for algorithmic data processing; the task of this stage is reduced to connecting the entities of the data model with the object model. Various tools of the ORM (Object Relational Mapping) class may be used for this, such as Hibernate and ADO.NET Entity Framework. As an alternative option, a resource description in the Recourse Definition Framework (RDF) format may be considered.

Application of data processing methods in an information system is predetermined by the degree of environment control. Delivery of all required data is possible within a controllable environment.

Methods of simulation modeling are used in a semicontrollable or uncontrollable environment.

In a controllable environment, problems of operational activity and planning are solved in the framework of one organization; in a manufacturing enterprise the problem is control of resources. Higher-level problems include prediction and assessment of production capabilities, bookkeeping tasks, staff management, and others. An expansion of this ideology is including suppliers and consumers into the activity process. Similar processes exist in government agencies, where the production process is replaced by the development of management decisions and the logistics of material flows is represented as a rule by the movement of various types of documents.

The methods for solving these problems can include modern modifications of econometric methods that are oriented at industrial supply of data, describing processes with a large number of characteristics and allowing implementation of topological and logical-mathematical models.

The next step in the development of numerical models are simulation models which reproduce a change in the system over time. Three types of simulation models are distinguished: event models, agent models, and system dynamics models. *Event models* implement the discrete-event approach describing an activity as a discrete sequence of events over time (discrete-event simulation, DES). An extension of this model is modeling the actions performed on a schedule.

The parameters for simulation models can be presented on the basis of econometric assessments, while the information systems of enterprises can serve as the suppliers of data (Moon, 2005). Smart devices possessing intelligence are becoming a substantial portion of information systems: signals from sensors and processing of data from knowledge bases allow smart devices to make decisions, adapt to the environment, etc.

Agent modeling is a more complex variation of simulation modeling which considers actions of autonomous, decentralized agents (Makarov et al., 2013). The behavior of the agents is modeled by applying methods of game theory, the theory of complex systems and their emergence, mathematical sociology, and a number of other methods.

A higher level of system integration is implemented by the methods of *system dynamics* and is used primarily for problems of the strategic level. System dynamics is the methodology and technique of mathematical modeling for constructing top-level models.

The final level for describing systems is the set of *heuristic* models. These models are created for making managerial decisions in systems where human beings act as structural components. Formalized models are created on this level for making managerial decisions that include such elements of human activity as creative and unconscious thinking. The methods of that level of abstraction are knowledge management, expertise, expert assessments, training, gaining experience, etc.

The sequence of economic-mathematical models of the abstract level and their implementation and integration are shown in Fig. 3 in the form of a V-diagram. The growth of information assets promotes transferring more and more abstract models into the class of numerical ones.

Analytical services in the corporate sector are implemented in ERP-class systems and the theory of data supply from local systems to the discrete-event model and the process-simulation models is worked out (Robertson, 2002).

IV. Implementation of the information model and the economic-mathematical model in application.

Economic-mathematical and information models find their embodiment in life in information systems. The models can be of two types: abstract or practical. Abstract models help form system perception, while practical ones help detect transactions, simulate reality, and predict the behavior of a system. To transfer economic-mathematical models to the class of applied models, industrial supply of data based on information models is required, as well as adaptation of data-processing methods.

The translation of activity in an information model and data processing procedures are shown in Fig. 4 presenting the basic layers of the architecture of a transactional system. An activity described by using the organizational structure and processes reproduces the logic of the activity. The processes are divided into two categories, operational and managerial activities, which are carried out by separate elements of the organizational structure. Managerial activities are presented in more detail in the integrational component.

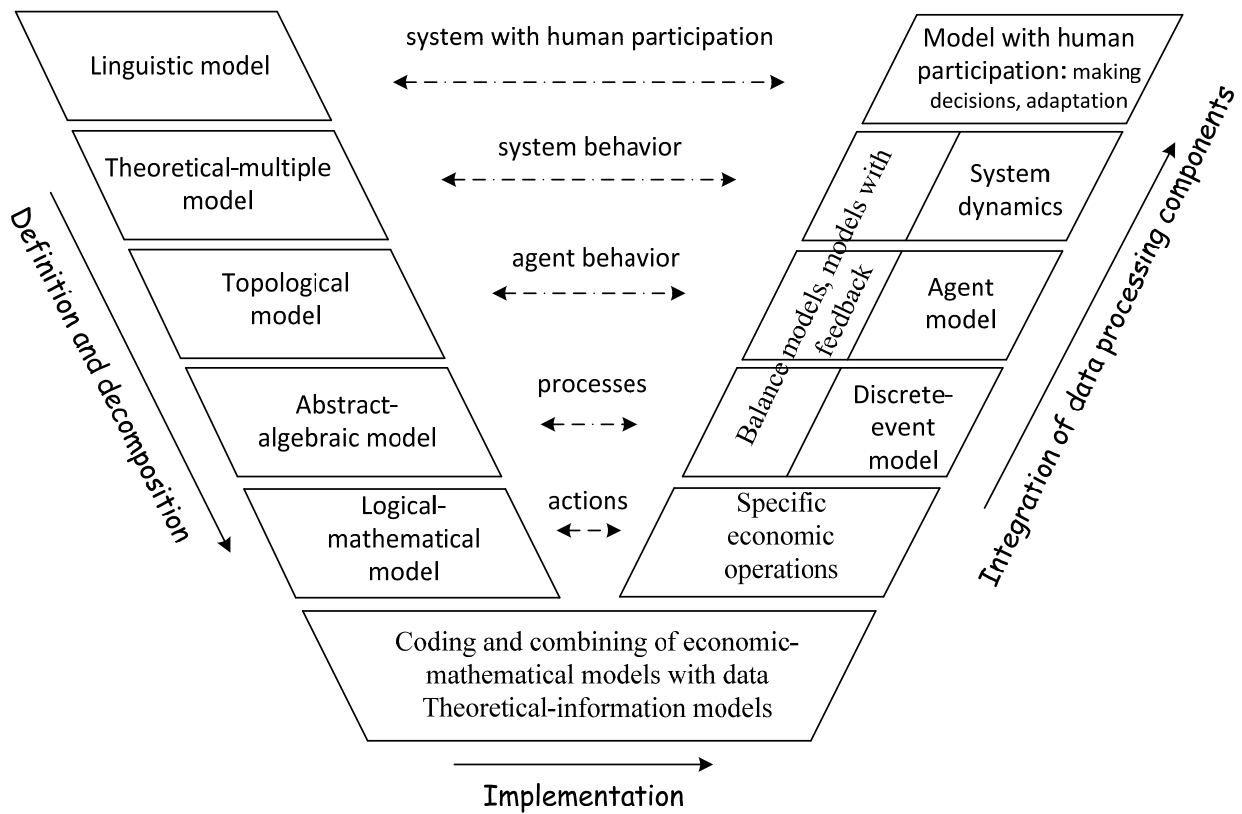

Fig. 3. V-diagram of economic-mathematical modeling

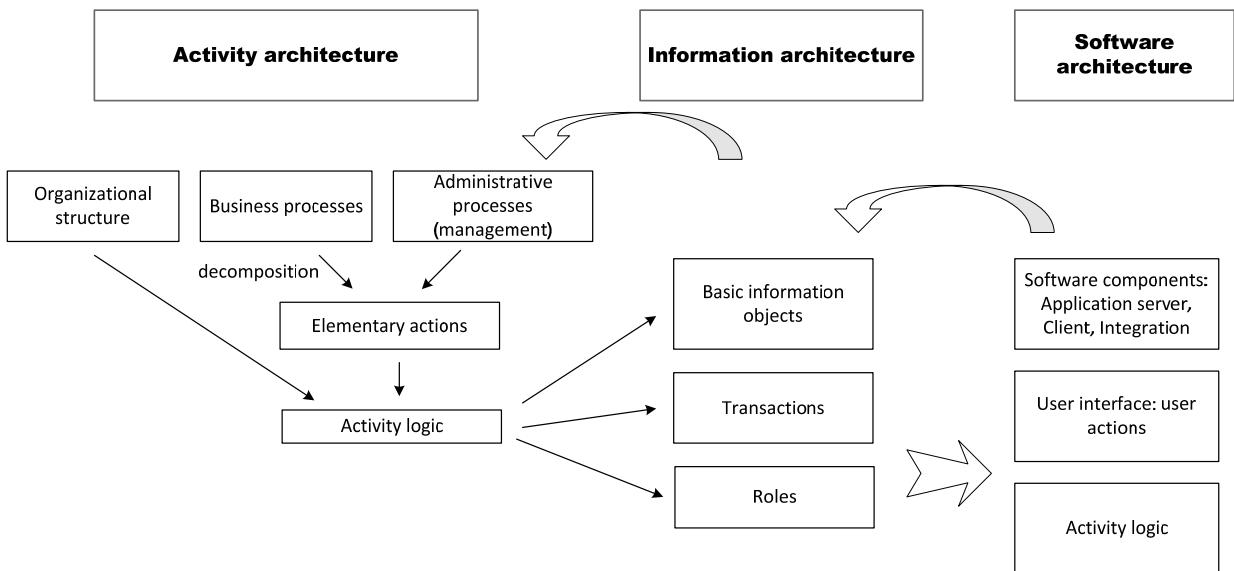

Fig. 4. Basic components by architecture layers

The information layer is represented by the basic information objects and transactions reflecting the transformation of basic objects. The organizational structure of a real-world

enterprise is transformed into a set of roles in an information system.

The software layer is aimed at organizing a set of interfaces for interactions with users, and

at implementing separate elements of activity logic that were not reflected in the data model. Human-machine interfaces are shown as a separate element of the layer allowing to enter new data and edit existing data.

Integrational systems constitute a second class of systems. Let us examine an integration model using the example of the information model of interagency interaction (Lipuntsov, 2016), entailing the arrangement of the interagency interaction through a data core. The data core represents a three-layer structure: the general core, the subject domain core, and the object-oriented portion of the core. The layers are able to interact by using the model of inter-level connections. The application of this model for collecting and analyzing data in the stock market is described in the article (Lipuntsov, 2016). The analysis of stock data assumes that information is available from various sources: tax agencies, statistics agencies, the national accounting depository, stock exchanges, and other sources.

In the information infrastructure of e-government, integrational systems are an element for presenting data and the technologies of analysis. Integration of governmental data is a necessary solution for satisfying the information demands of interdepartmental processes from

various state and corporate systems. The structure of the basic elements of the integrational platform of the infrastructure of the e-government of the Russian Federation is shown in Fig. 5.

The diagram shows the supply of data from governmental and commercial information systems. The current data of the universal core and of subject domains are generated based on the information supplied. These two core layers serve as the basis for generating the object-oriented core portion aimed at supplying information for the operational activity.

The second equally important task of the integration platform is supplying data for management purposes. Data marts and the results of data mining act as the data suppliers in this case, and all three core layers serve as data sources. This portion is where the economic-mathematical models embodied in the analytical component are implemented. The simulation models, which assume modeling the behavior of separate system elements or the system as a whole, are located in a separate module.

A decision support platform of data integration and analytical processing makes it simpler to conduct analysis and publish the results, and offers new analytical opportunities and facilitates data exchange.

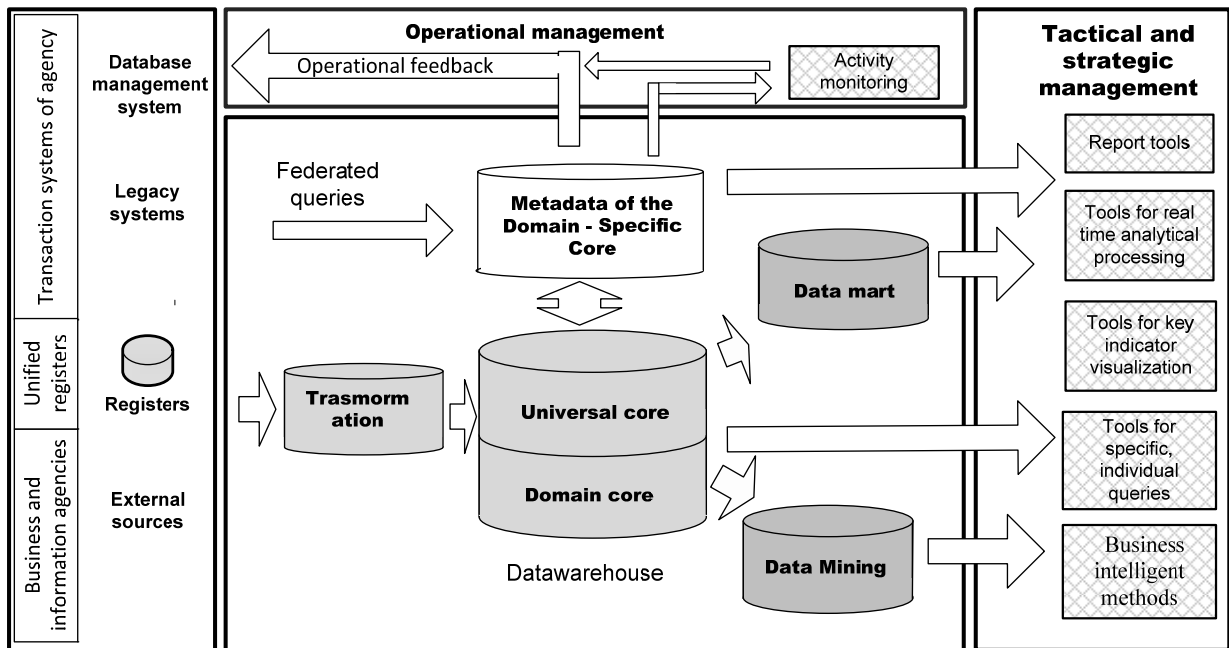

Fig. 5. Framework model of the structure and information flows of a platform for government data integration

Large-scale data integration models have already been implemented in various branches of the commercial sector. As an example of a large-scale integration system, we can look at the Global Distribution System (GDS) (Travel technology, 2016). The GDS consists of a network for booking airline tickets, hotel rooms, car rentals, and other tourist services. From the technical point of view, it is a collection of interconnected portals of travel agencies, internet booking sites, and major corporate systems. The basic suppliers of services for the ultimate clients are travel agencies integrating data from the systems for booking airline tickets, hotels, and cars. The GDS system is built on the basis of corporate systems such as Amadeus, Galileo, Sabre, and Worldspan (Ian Clayton, 2016). They belong to joint ventures of airline companies, car rental companies, and hotel groups.

If we look at the history of GDS development, a predecessor version was the Pegasus information system, in which initially all data were entered manually. Using a large number of employees occupied with data entry, the system had to be operated in India. The data entry process was labor-intensive and error-prone.

After the GDS information system was created, it became substantially faster to perform transactions. However, the process of launching and fine-tuning the GDS was not simple since all the corporate systems that needed to be connected were different. The need for standardization arose; protocols and standards were worked out. The corporate systems contained very rigid business rules which did not always allow the use of standards. Information transmitted to corporate systems should be accurate and correspond to rules of implemented business logic. Even years after the GDS has been launched, errors cropped up that could lead to a simple quotation marks resulting in system failure with catastrophic consequences and damaging of data integrity.

Currently, most travel services are purchased electronically, including in the form of a package of consolidated services in the three travel sectors: booking airline tickets, booking hotels, and car rental. In parallel with development of the GDS, corporate systems rendering similar services without intermediaries underwent improvements.

However, let us return to the infrastructure of the e-government of the Russian Federation.

If we examine the infrastructure services from the point of view of GDS development stages, then the multifunctional centers (MFCs) correspond to the transitional stage of development. The MFC currently performs the functions of data entry, obtaining electronic data and transforming them to print form, transmission of data from system to system, and other functions. An extended version of the MFCs should include standardization of data by subject domains, typification of processes, and the use of the developed standards in departmental systems. In order to obtain government services at a level comparable to the current development of services for purchasing tickets and booking hotels, much work remains to be done, especially in the field of standardization of information turnover.

Basic registers should become a separate element of the infrastructure of the electronic government of the Russian Federation being created. In the GDS, the primary element of the system framework is the Passenger Name Record (PNR). In the model of interdepartmental interaction, a general core and a subject domain core are used as such framework, while the object-oriented domain of services is built using the federal principle.

The federal model was adopted as the primary model for organizing interagency cooperation in Decree No. 487 dated June 1, 2016 issued by the Russian Government (Government of the RF, 2016). As international experience including the above-mentioned GDS shows, the federal model should rely on the mainframes that are the suppliers of operational data. In the case of electronic government, which is functionally far more diverse than ticket purchasing, a format combining a data repository, federal rules for working with local systems would be a more appropriate variation.

Conclusions. Creating an application entails implementing an information model reflecting the logic of activity and determines the content of accessible data and economic-mathematical models that predetermine the intelligence of an information system and the level of data processing.

Such a division is important for large-scale projects, the information and analytical components of which are located in a distributed

environment. Division into information and analytical models will allow to work out an ideology for creating construction kits for data collection and integration on the one hand, and, on the other hand, for implementing methods for analytical processing of these data. This is a large-scale task which should be solved for creating an e-government's information-analytical infrastructure. A construction kit is necessary for the end user (a civil servant, a citizen, or an employee of a commercial company), allowing to generate the required data set independently, and also to determine the data processing methods. Formulating the problem in this way entails the submission of the information-analytical infrastructure of the e-government as a set of information and analytical components. The configuration of modern applications should assume the addition of components that allow to obtain data from the external environment, as well as letting the user determine the data-processing methods and implementing user-defined data-processing scenario.

Further development of the information component is seen in a more complete presentation of the methods for creating models of those transaction systems, including creation of typical templates to reflect standard situations and a library of templates for subject domains.

In the section of data integration models, it would be reasonable to create an object description of the ontology in terms of classes and inheritances. That would be a good methodological foundation for improvement of information interaction model in the corporate and governmental sectors. Development of the

theme of data integration will be continued in the form of the description of the methodology for data transformation (Fig. 4) that will be applied for integration projects, as well as for forming separate layers of the core of government data and for describing the methodology of connections between various layers.

A substantial amount of information-analytical products focused on solving specific problems is currently created by the efforts of companies and agencies. The Russian Government's Analytical Center is holding a competition for determining the best information-analytical tools (Analytical Center of the Government of the RF, 2016). It should be noted that the description elements of the products to be submitted to the competition do not pay enough attention both to the presentation of systems from the perspective of describing the tools for forming an information base, and to methods of analytical data-processing. Applications are presented from the point of view of solving functional problems. A solution to local problems, no matter how elegant it may be, does not always fit into the surrounding infrastructure, except for cases when this is done with a goal in mind.

For large-scale informatization projects, it is not enough to have all types of activities and performer roles in a formalized representation; it is also necessary to apply industrial methods, i.e., standardize the methods for data presentation and methods for their analytical processing. In this case embedding separate components into the information-analytical infrastructure of e-government could prove to be promising.

REFERENCES

- [1] **J. Fowler, B. Perry**, Agent-Based Semantic Interoperability in InfoSleuth. SIGMOD, 1999 g. 1 : T. 28.
- [2] **D.C. Hay**, Data Model Patterns: A Metadata Map. Morgan Kaufmann, 2006.
- [3] **Ian Clayton**, GDS NEXT GENERATION SEAMLESS. 2016 g. 10.03.2017 g. URL: http://axes.com/encyc/archive/arcres/arcrates/users2/globalmarketing_about_gds.cfm
- [4] **W.H. Inmon, D. Linstedt**, Data Architecture: A Primer for the Data Scientist. [b.m.] : Morgan Kaufmann, 2014.
- [5] **K.C. Laudon, J.P. Laudon**, Management Information Systems, 2nd ed. Macmillan, 1988.
- [6] **Y. Lipuntsov**, An Information model of Interagency Communication Based on Distributed Data Storage, International conference electronic governance and open society: challenges in Eurasia. ACM (New York, N.Y., United States), 2016.
- [7] **Y.B. Moon, D. Phatak**, Enhancing ERP system's functionality with discrete event simulation, (2005) : Industrial Management & Data Systems 105(9).
- [8] **N. Robertson, T. Perera**, Automated data collection for simulation? Simulation Practice and Theory, (9) (2002) : [b.n.].
- [9] **C. Shamieh**, Continuous Engineering. IBM : John Wiley & Sons, 2014.

- [10] Travel technology Global distribution system. 2016 g. 10.03.2017 g. URL: https://en.wikipedia.org/wiki/Global_distribution_system
- [11] **R. Allen**, Matematicheskaya ekonomiya [Mathematical economy], Izdatelstvo instrannoy literatury, Moscow, 1963.
- [12] Analiticheskiy tsentr pri Pravitelstve RF. Konkurs «Luchshiy informatsionno-analiticheskiye instrumenty – 2016» [Analytical center for the Government of the Russian Federation. The contest «Best information and analytic tools – 2016»]. 2016 g. 10.03.2017 g. URL: <http://itcontest.ac.gov.ru/an2016/>.
- [13] **M.V. Gracheva, Yu.N. Cheremnykh, Ye.A. Tumanova**, Modelirovaniye ekonomicheskikh protsessov [Modeling of economic processes], Yuniti-Dana, Moscow, 2013.
- [14] **S. Karlin**, Matematicheskiye metody v teorii igr programmirovaniy i ekonomike [Mathematical methods in the theory of games, programming and Economics], Mir. Moscow, 1964.
- [15] **V. Kogalovskiy**, Proiskhozheniye ERP [The origin of ERP], Direktoru informatsionnoy sluzhby, 2002.
- [16] **Y. Lipuntsov**, Primeneniye informatsionnoy modeli mezhvedomstvennogo vzaimodeystviya dlya sbora i analiza dannykh po fondovomu rynku [Application of information model of interagency cooperation for data collection and analysis on the stock market], Sovremennyye informatsionnyye tekhnologii i IT-obrazovaniye, Fond sodeystviya razvitiyu internet-media, IT-obrazovaniya, chelovecheskogo potentsiala Liga internet-media, Moscow, 3 (12) (2016) 240–246.
- [17] **Y. Lipuntsov**, Printsipy sozdaniya ontologii dlya khranilishcha dannykh. Primer «vysheye obrazovaniye» [Principles of creation of the ontology for the data store. Example of «higher education»], Biznes. Obrazovaniye. Pravo, (3) (2016).
- [18] **Iu.P. Lipuntsov**, The information modeling stages, St. Petersburg State Polytechnical University Journal. Economics, 6(233) (2015) 196–205.
- [19] **V.L. Makarov, A.R. Bakhtizin**, Sotsialnoye modelirovaniye – novyy kompyuternyy proryv (agent-oriyentirovannyye modeli) [Social simulation – a breakthrough new computer (agent-oriented models)], Ekonomika, Moscow, 2013.
- [20] **M. Mesarovich, Ya. Takakhara**, Obshchaya teoriya sistem: matematicheskiye osnovy [General systems theory: mathematical foundations], Mir, Moscow, 1978.
- [21] Pravitelstvo RF O pervoocherednykh merakh, napravlennykh na sozdaniye gosudarstvennoy informatsionnoy sistemy «Yedinaya informatsionnaya sreda v sfere sistematizatsii i kodirovaniya informatsii» [The government of the Russian Federation On priority measures aimed at the creation of the state information system «Unified information environment in the sphere of systematization and coding of information»], Postanovlenii Pravitelstva RF № 487 ot 01.06.2016 g., 2016.
- [22] Rosstandart GOST 34.602-89 Informatsionnaya tekhnologiya. Kompleks standartov na avtomatizirovannyye sistemy. Tekhnicheskoye zadaniye na sozdaniye avtomatizirovannoy sistemy [Rosstandart GOST 34.602–89 Information technology. A set of standards for automated systems. Technical task on creation of automated system], 1990.

Lipuntsov Y.P. E-mail: lipuntsov@econ.msu.ru

СПИСОК ЛИТЕРАТУРЫ

- [1] **Fowler J., Perry B.** Agent-Based Semantic Interoperability in InfoSleuth. SIGMOD, 1999 г. 1 : Т. 28.
- [2] **Hay D.C.** Data Model Patterns: A Metadata Map. Morgan Kaufmann, 2006.
- [3] **Clayton Ian.** GDS NEXT GENERATION SEAMLESS. 2016 г. 10.03.2017 г. URL: http://axses.com/encyc/archive/arcrs/arcrates/users2/globalmarketing_about_gds.cfm
- [4] **Inmon W.H., Linstedt D.** Data Architecture: A Primer for the Data Scientist. [б.м.] : Morgan Kaufmann, 2014.
- [5] **Laudon K.C., Laudon J.P.** Management Information Systems. 2nd ed. Macmillan, 1988.
- [6] **Lipuntsov Y.** An Information model of Inter-agency Communication Based on Distributed Data Storage // International conference electronic governance and open society: challenges in Eurasia. ACM (New York, N.Y., United States), 2016.
- [7] **Moon Y.B., Phatak D.** Enhancing ERP system's functionality with discrete event simulation. 2005 : Industrial Management & Data Systems. Т. 105(9).
- [8] **Robertson N., Perera T.** Automated data collection for simulation? // Simulation Practice and Theory. 2002 : [б.н.]. Т. 9.
- [9] **Shamieh C.** Continuous Engineering. IBM : John Wiley & Sons, 2014.
- [10] Travel technology Global distribution system. 2016 г. 10.03.2017 г. URL: https://en.wikipedia.org/wiki/Global_distribution_system
- [11] **Аллен Р.** Математическая экономия. М.: Изд-во иностр. лит., 1963.
- [12] Аналитический центр при Правительстве РФ. Конкурс «Лучшие информационно-аналитические инструменты – 2016». 2016 г. 10.03.2017 г. URL: <http://itcontest.ac.gov.ru/an2016/>
- [13] **Грачева М.В., Черемных Ю.Н., Туманова Е.А.** Моделирование экономических процессов. М.: Юнити-Дана, 2013.
- [14] **Карлин С.** Математические методы в теории игр программирования и экономике. М.: Мир, 1964.
- [15] **Когаловский В.** Происхождение ERP // Директору информационной службы, 2002 г.



[16] **Липунцов Ю.** Применение информационной модели межведомственного взаимодействия для сбора и анализа данных по фондовому рынку // Современные информационные технологии и ИТ-образование. М.: Фонд содействия развитию интернет-медиа, ИТ-образования, человеческого потенциала Лига интернет-медиа. 2016. Т. 12. № 3. С. 240–246.

17. **Липунцов Ю.П.** Принципы создания онтологии для хранилища данных. Пример «высшее образование» // Бизнес. Образование. Право. 2016. № 3.

[18] **Липунцов Ю.П.** Этапы информационного моделирования // Научно-технические ведомости СПбГПУ. Экономические науки. 2015. № 6(233). С. 196–205.

Липунцов Ю.П. E-mail: lipuntsov@econ.msu.ru

[19] **Макаров В.Л., Бахтизин А.Р.** Социальное моделирование — новый компьютерный прорыв (агент-ориентированные модели). М.: Экономика, 2013.

[20] **Месарович М., Такахара Я.** Общая теория систем: математические основы. М.: Мир, 1978.

[21] Правительство РФ О первоочередных мерах, направленных на создание государственной информационной системы «Единая информационная среда в сфере систематизации и кодирования информации» // Постановлении Правительства РФ № 487 от 01.06.2016 г. 2016 г.

[22] Росстандарт ГОСТ 34.602–89 Информационная технология. Комплекс стандартов на автоматизированные системы. Техническое задание на создание автоматизированной системы, 1990.

Статья поступила в редакцию 07.07.16

DOI: 10.18721/JE.10208
UDC 338.984

USING ECONOMIC AND MATHEMATICAL MODELS AND METHODS TO ASSESS THE HUMAN CAPITAL OF A COMPANY IN THE FIELD OF IT INDUSTRY

L.A. Strelnikova, M.M. Lembrikova

Peter the Great Saint-Petersburg Polytechnic University, St. Petersburg, Russian Federation

The problem of effective use of human resources represents an extremely difficult socio-economic challenge, therefore, currently there has been a marked increase in interest in the evaluation of human capital as the most important resource that provides competitive advantages for modern companies in every field. The aim of this study is to assess human capital of the company's employees on the basis of expert approach using a competence model and aggregated indices randomization method. The article clarifies the concept of human capital as the basic structural element of intellectual capital, presents a brief overview of the most common models and methods of human capital assessment and demonstrates the necessity of realization of a competence-based approach in the evaluation of the company's employees and personnel segmentation. The possibility and the advantage of application of the aggregated indices randomization method (AIRM) to produce a comprehensive assessment of the level of competence of employees of the international division of a Russian company in the field of IT industry is demonstrated. The division based in St. Petersburg is engaged in the development of custom software and modernization of corporate information systems in the financial industry, telecommunications, online-travel, mobile development, Internet projects and media. This study employs mathematical methods (aggregated indices randomization method, expert score), comparative methods (analysis, synthesis, classification), as well as the general logic methods of scientific concept construction. The scientific novelty of the research lies in the fact that, based on existing research, the authors propose a new instrumental technique, realizing the algorithms for assessing the human capital of the company's employees, the results of which reveal the priorities in the field of recruitment, development and motivation of the staff, thereby implementing a rational approach to using human and financial resources of the company. The practical significance of the study lies in the development of methodological tools for human capital assessment that can be used for managing other information technology companies.

Keywords: human capital; models and methods of human capital assessment; competence; competence; competence model; aggregated indices randomization method; personnel segmentation; competitiveness

Citation: L.A. Strelnikova, M.M. Lembrikova, Using economic and mathematical models and methods to assess the human capital of a company in the field of IT industry, St. Petersburg State Polytechnical University Journal. Economics, 10 (2) (2017) 88–97. DOI: 10.18721/JE.10208

ПРИМЕНЕНИЕ ЭКОНОМИКО-МАТЕМАТИЧЕСКИХ МОДЕЛЕЙ И МЕТОДОВ ДЛЯ ОЦЕНКИ ЧЕЛОВЕЧЕСКОГО КАПИТАЛА СОТРУДНИКОВ КОМПАНИИ В СФЕРЕ ИТ-ИНДУСТРИИ

Л.А. Стрельникова, М.М. Лембрикова

Санкт-Петербургский политехнический университет Петра Великого,
Санкт-Петербург, Российская Федерация

Проблема эффективного использования человеческих ресурсов представляет собой чрезвычайно сложную социально-экономическую задачу, поэтому в настоящее время значительно возрос интерес к оценке человеческого капитала как важнейшего

ресурса, обеспечивающего конкурентные преимущества современных предприятий в любой сфере деятельности. Цель исследования – проведение оценки человеческого капитала сотрудников предприятия на основе экспертного подхода с использованием модели компетенций и метода рандомизированных сводных показателей. Уточнено понятие «человеческий капитал» как базовый структурный элемент интеллектуального капитала, проведен краткий обзор наиболее распространенных моделей и методов оценки человеческого капитала, обоснована необходимость реализации компетентностного подхода при оценке сотрудников предприятия и сегментации персонала. Показана возможность и преимущество применения метода рандомизированных сводных показателей (МРСП) для получения комплексной оценки уровня компетентности сотрудников российского подразделения международной компании в сфере IT-индустрии. Подразделение в Санкт-Петербурге занимается разработкой заказного программного обеспечения и модернизацией корпоративных информационных систем в области финансовой индустрии, телекоммуникаций, онлайн-путешествий, мобильной разработки, интернет-проектов и масс-медиа. Использовались математические методы (метод рандомизированных сводных показателей, экспертная балльная оценка), сравнительно-сопоставительные методы (анализ, синтез, классификация), а также общелогические методы построения научной концепции. Научная новизна исследования состоит в том, что на основе существующих разработок предложена новая инструментальная методика, реализующая алгоритмы оценки человеческого капитала сотрудников предприятия, результаты которой позволяют выявить приоритетные направления в сфере подбора, развития и мотивации персонала, тем самым осуществить рациональный подход к использованию человеческих и финансовых ресурсов предприятия. Практическая значимость исследования заключается в разработке методического инструментария по проведению оценки человеческого капитала, который может быть использован в управленческой деятельности других предприятий в сфере информационных технологий.

Ключевые слова: человеческий капитал; модели и методы оценки человеческого капитала; компетенция; компетентность; модель компетенции; метод рандомизированных сводных показателей; сегментация персонала; конкурентоспособность

Ссылка при цитировании: Стрельникова Л.А., Лембрикова М.М. Применение экономико-математических моделей и методов для оценки человеческого капитала сотрудников компании в сфере IT-индустрии // Научно-технические ведомости СПбГПУ. Экономические науки. 2017. Т. 10. № 2. С. 88–97. DOI: 10.18721/JE.10208

In the context of modern Russian economy focused on innovative socially-oriented development model, the community is rapidly becoming conscious of the fact that a company's development, competitiveness and efficiency is determined not by the physical assets but by the human capital, which is a combination of knowledge, skills, innovativeness and creativity of people, which allow to create well-being, both in personal and social terms.

In this regard, the assessment and accumulation of human capital, as the most valuable resource of intellectual capital, is one of the companies' high-priority strategic tasks. It should be noted that the process of assessing the human capital of a company is very complex and highly individual, because each employee is a unique person, therefore, it is necessary to take into account the characteristics specific to a particular employee.

For the implementation of human capital assessment of companies' employees by Russian and foreign researchers, various models and methods are proposed that take into account the quantitative and qualitative characteristics of a person's abilities and skills, and also determine the value of human capital in cost and natural values [6]:

1. Cost-based models where the initial cost, the replacement cost and the opportunity cost of human assets are determined.
2. A monetary model based on determining the economic effect of the use of human capital.
3. Natural (temporary) assessment, implying the measurement of human capital in person-years of learning.
4. Values of human capital taking into account intangible behavioral values and monetary economic value.

Accordingly, the cost and value of human capital accumulated by individuals, the volume

of investments in human capital, the competitive advantages of the company resulting from the accumulation of human capital are subject to measurement.

One of the most common methods is the calculation of the human capital of an individual and its evaluation in the structure of the intellectual capital of the company. The theory is held by scientists such as Farr, Dublin and others. The method is based on the attempt to estimate the discounted cost of the flow of costs associated with the formation of human capital and the future flow of income, which will ensure the receipt of human capital of a particular individual [2].

An approach to the evaluation of human capital by analogy with physical capital has a fairly wide application. Within the framework of this method, the «initial cost» of a particular employee is determined by means of various methods of testing the employees of a company. Then, the coefficient of forgetting the knowledge is revealed, taking into account the term of participation of a particular employee in the company's activities.

With the expert approach, qualitative indices that characterize both the individual characteristics of a particular employee and the properties of company's employees in the aggregate are evaluated. The calculation procedure is carried out in three stages:

1. Identification of the key indices that describe the employee's contribution to the intellectual capital of the company.
2. Definition of a point scale for the estimation of each index.
3. Determination of the weight coefficient for each index, based on how often it is manifested in the employee being evaluated.

The average score for each employee is determined through calculations. The results obtained are analyzed and compared with the benchmark metrics obtained by the empirical method. The expert approach includes various modifications and is a necessary component of the assessment of human capital.

The evaluation of human capital can be carried out on the basis of directed investments. The costs for the professional development of a particular employee or all employees of the company are considered as long-term investments in the intellectual capital of the

company. However, investments in human capital are economically justified only if the contribution of a particular employee improves the efficiency of the company.

This implies the expediency of segmentation of the personnel of the company. The main human resource management principle is the understanding that every employee carries a different level of value to the company, the same as every customer is important for the company, however, not equally, but depending on the amount of product consumed. On this basis, there are employees several times more valuable to the company than others [13].

The methodology for assessment of human capital of the employees of the Russian division of an international company in the field of IT industry is presented within the framework of this study on the basis of expert approach using a competence model and the aggregated indices randomization method.

The algorithm for assessing human capital of the company's employees was as follows:

1. Competence modelling based on five initial characteristics reflecting the competence of employees.
2. Determination of criteria for evaluating staff by developing an evaluation scale.
3. Determination of the estimation method. In this study, the aggregated indices randomization method (AIRM) was applied, which is used to evaluate complex objects. In our case, this is the individual competence of the employee, represented as a set of assessments of individual competences. In the conditions of uncertainty, it is rather difficult to accurately indicate the weight of specific competences, since it can be different for each job position, which determined the choice of this method.
4. Evaluation of employees according to the established rules.
5. Analysis of the results obtained by compiling an ASPID diagram of aggregated competence assessments of the employees of the company under study.

6. Segmentation of personnel for management decisions regarding employees of the company under study, including the development of individual programs for professional development of employees.

The competence model was used to assess the human capital of the employees of IT

companies. At the present time the approach to employee evaluation based on this model is the most common in both foreign companies and Russian organizations.

The competence of the individual worker (C_x) was evaluated with the help of a set of baseline characteristics:

- x_1 – functional competences level;
- x_2 – managerial skills level;
- x_3 – corporate competences level;
- x_4 – innovative competence level;
- x_5 – social competence level.

In particular, the Senior .NET Developer position assumes that within the framework of functional competences the employee should have the following necessary skills:

- 1) understanding of C #, including the latest version of the ASP.NET MVC framework; ASP.NET MVC;
- 2) possession of software design skills;
- 3) possession of skills of object-oriented programming (OOP), and object-oriented design (OOD);
- 4) knowledge of design patterns;
- 5) knowledge of the database management system MS SQL Server and its components SSRS, SSIS;
- 6) knowledge of JavaScript and JavaScript-frameworks (jQuery, Angular.js, Backbone.js);
- 7) the ability to use the methods of test-driven development (TDD), as well as commercial applications on the .NET platform;
- 8) English language proficiency.

Below is a fragment of a competence model drawn up by the authors of this study. For example, such factor as the ability to make non-

standard solutions was taken into account when determining the innovative competences (Fig. 1).

The above characteristics form the vector: $x = (x_1, \dots, x_n)$. Each characteristic constitutes certain features – y_n . If confined only to a set of estimates for each competence, then, most likely, it will not be possible to compare all the employees together in relation to all the competences at once. For example, one person's level of functional or corporate competence can be very high, but there is hardly a worker who surpasses others in all the competences at the same time.

Therefore, the aggregated indices randomization method (AIRM), which allows for multi-criteria evaluation of complex objects under conditions of uncertainty with the use of incomplete, inaccurate and non-numerical information, is used to analyze the evaluation summary of staff competence. This method was developed by Khovanov based on the ASPID (Analysis and synthesis of indices in the information deficit) methodology [18].

The values of five baseline characteristics x_1, \dots, x_5 were determined within the framework of this study. The results are presented on the basis of a random sample of employees of the studied IT companies in the amount of 15. In total, 82 people participated in the evaluation activities.

As criteria, a scale for assessing behavioral indices was developed, which includes four levels:

- 0 – almost never manifested / not expressed;
- 1 – manifested sometimes / individual elements are expressed;
- 2 – is manifested in most situations / most of the elements are expressed;
- 3 – manifested always, in all situations / fully expressed.

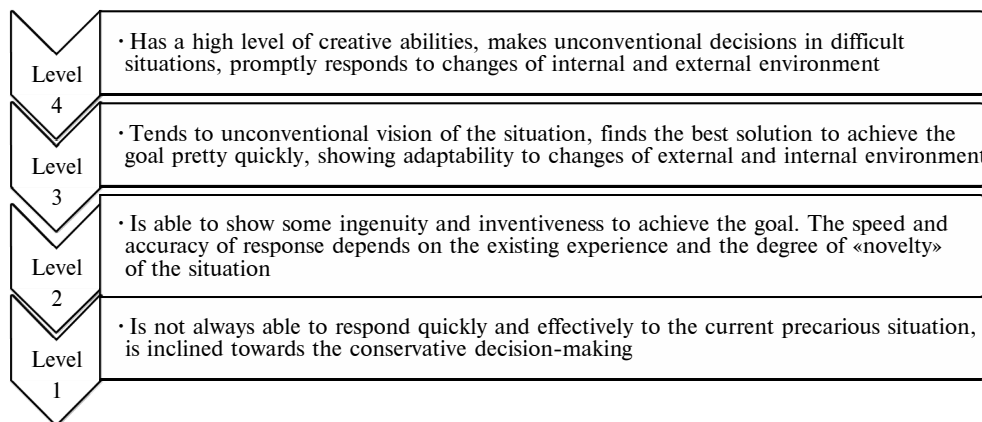

Fig. 1. Fragment of competence model for evaluation of the employees of IT companies

Table 1

Data (fragment) for determining the level of functional competences

Behavioral indices	Frequency of manifestation / intensity in employees														
	1	2	3	4	5	6	7	8	9	10	11	12	13	14	15
Performs work qualitatively	2	3	2	1	1	3	3	1	3	2	2	2	2	3	3
Works with enthusiasm and interest	3	2	1	1	1	3	2	1	2	2	2	2	2	3	2
Does more than is formally required	1	3	1	1	1	3	2	1	2	2	2	2	1	3	1
Takes new tasks	2	2	1	1	1	3	3	1	2	2	1	2	2	2	2
Total score for all indices	8	10	5	4	4	12	10	4	9	8	7	8	8	11	8
Value	2.00	2.50	1.25	1.00	1.00	3.00	2.50	1.00	2.25	2.00	1.75	2.00	2.00	2.75	2.00

Below is a fragment of the data used to determine the level of functional competences on the basis of such index as passion for work (loves the job, tends to do it the best way possible, using existing knowledge and experience) (Tab. 1).

All indices that reflect the levels of all the above competences of the company's employees are defined similarly.

The final calculations of the competence values of the company's employees on the basis of five characteristics of the competence level are presented in Tab. 2.

Next, the smallest and largest values of the baseline characteristics were determined, the level of the particular competences of employees was defined.

Table 2

Competence values of the company's employees

Employee	x_1	x_2	x_3	x_4	x_5
1	1.90	1.70	1.60	1.00	2.00
2	2.2	2.1	2.1	2.5	1.5
3	1.50	1.50	1.50	1.50	1.00
4	1.50	1.50	1.60	2.00	1.00
5	2.0	1.4	1.3	1.0	0.0
6	2.7	2.8	2.5	2.0	3.0
7	2.0	1.8	2.0	2.0	2.0
8	1.0	1.1	1.3	1.5	2.0
9	1.20	1.70	1.30	1.50	1.50
10	1.8	1.7	2.0	2.0	2.0
11	1.10	1.30	1.40	2.00	1.50
12	1.5	1.6	2.0	1.5	1.5
13	1.40	1.50	1.50	1.50	1.50
14	2.0	2.1	2.8	2.5	3.0
15	1.50	1.60	1.50	1.50	1.50

x_1 : min = 1.3; max = 3.0;

x_2 : min = 1.1; max = 2.7;

x_3 : min = 1.1; max = 2.8;

x_4 : min = 1.0; max = 2.7;

x_5 : min = 0; max = 2.5.

The function $q_i = q_i(x_i)$ is determined by the following formulas:

For the increasing function:

$$q_i(x_i) = \begin{cases} 0 & x_i \leq \min_i, \\ \frac{x_i - \min_i}{\max_i - \min_i} \min_i & \langle x_i \leq \max_i, \\ 1 & x_i \rangle \max_i. \end{cases} \quad (1)$$

For the decreasing function:

$$q_i(x_i) = \begin{cases} 1 & x_i \leq \min_i, \\ \frac{\max_i - x_i}{\max_i - \min_i} \min_i & \langle x_i \leq \max_i, \\ 0 & x_i \rangle \max_i. \end{cases} \quad (2)$$

Let us construct the system of indices q_1, \dots, q_5 , corresponding the assessment of competences of employees, in terms of the five criteria mentioned above, using formula (1) for the increasing function (Tab. 3).

Therefore, it is possible to draw a preliminary conclusion who is the most competent employee by each criterion. Thus, for example, by the criterion q_1 , the most competent employees are 2 and 4. Employees 5, 7 and 14 also have a fairly high level of competence by this criterion. It is worth noting that there is no such employee who would be more competent than the rest by all the criteria at the same time. Determination of (w) is a crucial moment in the summary assessment of human capital. Each component has its own «importance» or «value», the exaggeration or understatement of which can change the final assessment in the construction of the aggregated index [1].

Table 3

Competence indices for each employee (without weights), in points

Employee	q ₁	q ₂	q ₃	q ₄	q ₅
1	0.529	0.353	0.200	0.000	0.667
2	0.647	0.588	0.600	1.000	0.500
3	0.294	0.235	0.133	0.333	0.333
4	0.294	0.235	0.200	0.667	0.333
5	0.588	0.176	0.067	0.000	0.000
6	1.000	1.000	0.867	0.667	1.000
7	0.588	0.412	0.467	0.667	0.667
8	0.000	0.000	0.000	0.333	0.667
9	0.118	0.353	0.000	0.333	0.500
10	0.471	0.353	0.467	0.667	0.667
11	0.059	0.118	0.067	0.667	0.500
12	0.294	0.294	0.467	0.333	0.500
13	0.235	0.235	0.133	0.333	0.500
14	0.588	0.588	0.667	1.000	1.000
15	0.294	0.294	0.133	0.333	0.500

The additional data on the weight of competences should be used in staff assessment. For example, innovation competence is a very important factor in the successful performance of an IT company's employees. Also, a large number of «incomparable» staff makes it worthwhile to introduce an aggregated index, which allows to linearly «harmonize» all evaluated employees at the level of their general competence, taking into account the values of the indices q_1, \dots, q_5 , as well as the weight of the competences in the coefficients w_1, \dots, w_5 . In other words, this figure reflects a person's competence not for each competence separately, but for all competences at once, taking their importance into account.

Under real conditions some additional information on the weighting factors is available, not of a numerical, but a comparative character, for example, «functional competence is more important than corporate» or «the level of social intelligence is, according to experts, just as important as the level of innovation activity».

Thus, non-numeric information is the most stable and easy to read in this case; it can be represented as a system of equations and inequalities (3):

$$I = \{w_r > w_s; w_u = w_v, \dots\}. \quad (3)$$

Information about the relative weighting characteristics can be represented as a system of inequalities for the weighting coefficients (4):

$$I = \{w_2 > w_1 > w_3 > w_4 > w_5 \dots\}. \quad (4)$$

The weighting coefficients of the competence characteristics of employees were identified by the expert commission, depending on their value for the studied IT companies. The functional competence (x_1) is the most important for the ordinary employees of the company; followed by the innovative competence (x_4), then social competence (x_5), then corporate competence (x_3), and finally, the managerial competence (x_2).

Let us define the procedure for the formation of scales of activities W_i . The first type of competence is measured on the 3-point qualimetric scale, $W_1 = \{3, 2, 1\}$; second, third and subsequent on the 2-score $W_2 = W_3 = W_4 = W_5 = \{2, 1\}$, (i.e., m_i is the number of reference points in the i -scale that is equal to 3, 2, 2, 2, 2 respectively).

For each ω_{ik} reference point of all W_i competence scales, a specific quantity equivalent was calculated, that is, a weighting factor.

The total number of equivalents is defined by formula (5):

$$n = \sum_i m_i \quad (5)$$

$$n = 3 + 2 + 2 + 2 + 2 = 11.$$

Tab. 4 shows the values of the reference points of each competence evaluation scale (k is the current number of the reference point in the i -th scale).

Thus, we have obtained a scale of W vector evaluations, having $L = 48$ control points.

Using a 10-point scale is more familiar. Transition is possible by sorting the combination of values by descending gl values, and isolating the 9-limit values (0.59; 0.53; 0.51; 0.46; 0.43; 0.39; 0.36; 0.31; 0.26; 0.24). separating groups of evaluation combinations that can be correlated with final estimates of the scale $I = \{1, 2, 3, 4, 5, 6, 7, 8, 9, 10\}$.

The results of the evaluation of each employee of the studied IT company are presented in Tab. 5.

On the basis of determination of weight characteristics of each of the five competences ($X_1 = 0.352$, $X_2 = 0.094$; $X_3 = 0.116$; $X_4 = 0.131$; $X_5 = 0.124$) and calculation of the aggregated values of competence of each evaluated employee of the studied IT company, an ASPID diagram was constructed (Fig. 2).

Table 4

Values of reference points of rating scales

Scales	Reference points	Rating weight
$i = 1$ w_1 $m_1 = 3$ $k = 1, 2, 3$	$\omega_{11} = 3$	$d_{11} = 0.23$
	$\omega_{12} = 2$	$d_{12} = 0.15$
	$\omega_{13} = 1$	$d_{13} = 0.07$
$i = 2$ w_2 $m_2 = 2$ $k = 1, 2$	$\omega_{21} = 2$	$d_{21} = 0.11$
	$\omega_{22} = 1$	$d_{22} = 0.04$
$i = 3$ w_3 $m_3 = 2$ $k = 1, 2$	$\omega_{31} = 2$	$d_{31} = 0.10$
	$\omega_{32} = 1$	$d_{32} = 0.03$
$i = 4$ w_4 $m_4 = 2$ $k = 1, 2$	$\omega_{41} = 2$	$d_{41} = 0.10$
	$\omega_{42} = 1$	$d_{42} = 0.05$
$i = 5$ w_5 $m_5 = 2$ $k = 1, 2$	$\omega_{51} = 2$	$d_{51} = 0.07$
	$\omega_{52} = 1$	$d_{52} = 0.05$

Table 5

Evaluation of each employee on a 10-point scale

Employee	Type of performance assessment	$g_t^{\circ}G$	Final score
1	2,2,2,2,1	0.46	7
2	2,2,2,2,2	0.53	9
3	2,1,2,2,2	0.48	8
4	2,2,2,2,1	0.46	7
5	1,2,1,1,1	0.31	3
6	2,2,2,2,2	0.53	9
7	2,2,2,1,2	0.53	9
8	1,1,1,1,2	0.26	2
9	1,2,2,1,2	0.42	5
10	2,2,2,2,2	0.53	9
11	2,2,1,1,2	0.41	5
12	1,1,1,2,1	0.29	2
13	1,2,2,2,2	0.45	6
14	2,2,2,2,2	0.53	9
15	2,1,2,2,2	0.46	7

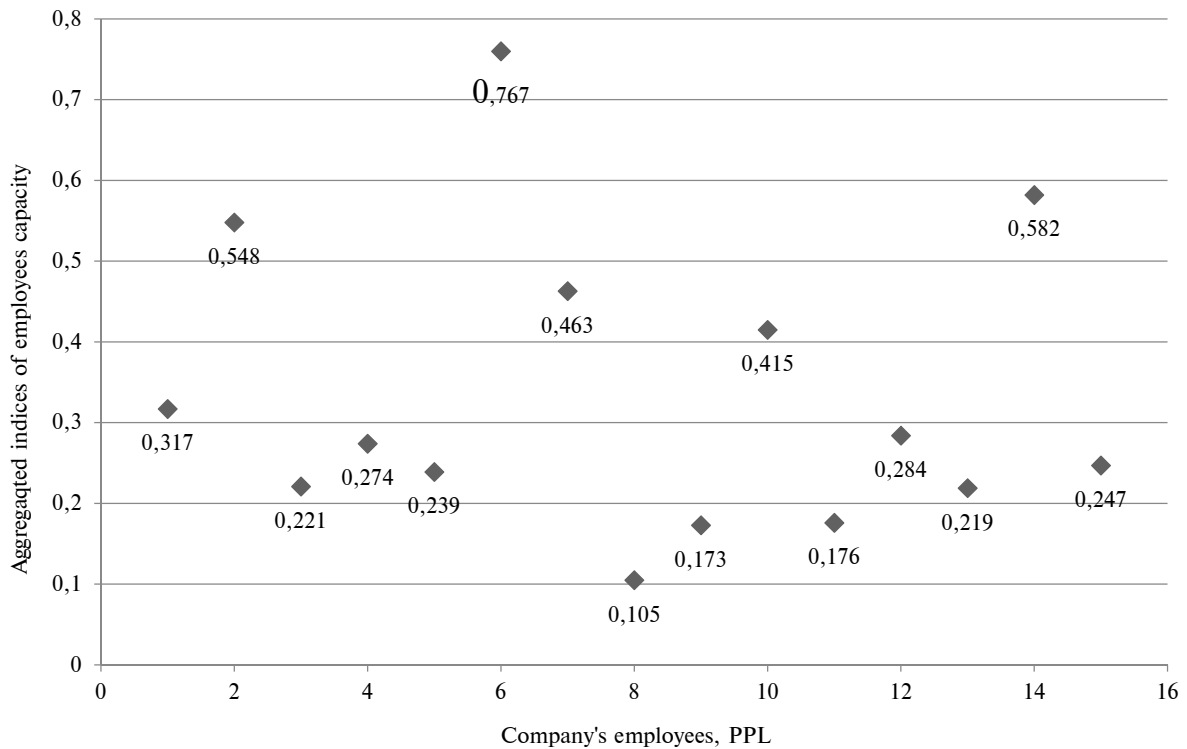

Fig. 2. Composite competence ratings of the IT company's employees

It was concluded on the basis of the presented diagram that the most competent employee is 6 (competence index is 0.767), followed by employees 14 and 2 (competence indices are 0.582 and 0.548, respectively). However, this is just a small part of the evaluated employees who have a fairly high level of competence.

For more detailed analyses of the company, the authors propose segmentation, which consists of four groups (similar to the matrix of the Boston Consulting Group): «Stars», «Cash cows», «Dogs» and «Problem children».

The heads of the company's departments were involved in the evaluation as experts. The first group (8 people), «Stars», are the employees who have been working for the company for more than two years, thus repeatedly underwent education and training to improve their professional skills. As already mentioned, 8 people belong to «Stars», but according to the aggregated indices only one of them is on the 8th level of competence (10-point rating scale); 7 people occupy the 7th position. Although this group is the smallest in size, it is the one of the utmost value for the company.

The second group (43 people), «Problem children», is characterized by a high level of performance potential and requires a fairly significant investment in order to develop it. Among the employees belonging to the «Problem children» category, 7 persons occupy the 6th level of competence, 36 occupy the 5th level. Upon receiving sufficient knowledge and accumulating experience, a gradual transition to the «Stars» takes place.

The third group (19 people) is «Cash cows». This group is characterized by a high level of productivity. This is the least attractive group from the point of development, since the functionality performed by the employees in most cases does not require development of any additional skills in relation to the company. 6 people from the «Cash cows» occupy the 4th level, 13 people the 3rd level.

The fourth group (12 people) is «Dogs». Basically, these are the new employees who are being trained at the moment. They have a low level of competence and do not bring profits. Trainings and seminars which will identify potential employees and weed out the least

qualified are required for transition to another group. In the «Dogs» category 9 people occupy the 2nd position, and 3 people have shown a very low level of competence, so the company decided to dismiss these trainees, without waiting for the end of the probationary period.

Taking the profit index for 100%, an average profit of «Stars» is 42%, 37% for «Problem children», 18% for «Cash cows», and 3% for «Dogs». Thus, a «Star» brings 5,02% of the profits for the studied IT companies, a «Problem Child» brings 0.96%, a «Cash Cow» brings 0.64%, and a «Dog» brings 0.32%. Thereafter, it is urgent to create a staff development program, aimed at increasing the number of «earning» employees.

The evaluation of human capital of the employees of IT company identified the need for the development of innovation and social competences. Accordingly, the company needs to develop a set of measures aimed at matching the real situation with the desired profile according to the developed competence profile. The purpose of the proposed activities is to reduce the difference between the existing and the required level of competence and, as a consequence, facilitate the development of the intellectual capital of the company, as human capital is the basis of its structure.

It should be borne in mind that investment in staff will be economically viable if it provides a high level of income to the company. The human capital evaluation requires an economic assessment of the knowledge acquired through education and experience, not only in terms of the accumulation of past investments in human capital accumulated in the reserve, but also in terms of the opportunity to acquire new knowledge in the future [7].

It is worth pointing out that human capital, as a form of intangible capital, cannot be separated from those to whom it belongs, and cannot be copied or reproduced in any other organization. Managers of domestic enterprises need to pay greater attention to the formation, accumulation and development of human capital using the most appropriate and effective tools, such as: the development of the strategy of selecting new recruits, the creation of a system for evaluation and continuous training of personnel, the implementation of a set of material and moral incentives for employees.

REFERENCES

- [1] **T. Alekseeva**, Otsenivaem uroven' kompetentnosti [Assess the level of competence], Spravochnik po upravleniiu personalom, (1) (2008) 64–71.
- [2] **K.K. Arabian**, Otsenka chelovecheskogo kapitala [Оценка человеческого капитала] : sb. dokl. po itogam Vseros. nauch.-prakt. konf., Moskva, 10–19 marta 2010 g. Pod obshch. red. prof. O.N. Mel'nikova, Kreativnaia ekonomika, Moscow, (2010) 62–64.
- [3] **A.E. Basova, A.S. Shamigova**, Chelovecheskii kapital i investitsii v chelovecheskii kapital organizatsii [Human capital and investment in human capital of the organization], Aktual'nye voprosy i perspektivy nauki i obrazovaniia: mater. Mezhdunar. zaoch. nauch.-prakt. konf. Nauch.-izd. tsentr «Mir nauki», (2016) 61–64.
- [4] **M.V. Grechko, I.V. Goncharov**, Chelovecheskii kapital, chelovecheskie resursy, intellektual'nyi kapital: vzaimosviaz' i razlichie kategorii [Human capital, human resources, intellectual capital: the relationship and distinction categories], Ekonomika i predprinimatel'stvo, 2-2 (67-2) (2016) 243–249.
- [5] **S.N. Zhuk**, Otsenka effektivnosti funktsionirovaniia slozhnykh sistem po ierarkhicheskoi sisteme pokazatelei [Assessment of efficiency of functioning of complex systems on a hierarchical system of indicators], Trudy SPIIRAN, (26) (2013) 194–203.
- [6] **E.V. Kovalenko, I.V. Ignashkina**, Otsenka chelovecheskogo kapitala sotrudnika predpriatiia [Evaluation of human capital employee], Nauchno-metodicheskii elektronnyi zhurnal «Kontsept»3 (13) (2015) 3171–3175.
- [7] **K.A. Noskova**, Otsenka chelovecheskogo kapitala i-go sotrudnika organizatsii [Evaluation of human capital of the ith employee of the organization], Aktual'nye voprosy ekonomicheskikh nauk: mater. II Mezhdunar. nauch. konf. (g. Ufa, aprel' 2013 g.), Leto, Ufa, (2013) 4–8.
- [8] **N.A. Osadchaia, A.I. Kravchenko**, Primenenie ekonomiko-matematicheskikh metodov i modelei dlia otsenki rezul'tativnosti kadrovogo potentsiala stroitel'noi organizatsii [The use of economic-mathematical methods and models for assessing the effectiveness of a personnel capacity building organization], Nauchnoe obozrenie, (12) (2013) 274–277.
- [9] **V.F. Puchkov, G.V. Gratsinskaia**, Razrabotka i primenenie matematicheskikh modelei dlia resheniia zadach upravleniia ekonomicheskimi sistemami [The development and application of mathematical models for solving problems of economic systems management], Monogr., Izd. dom «BIBLIO-GLOBUS», Moscow, 416 p.
- [10] **E.G. Pushina**, Rol' sistemnogo podkhoda v primenenii ekonomiko-matematicheskikh metodov [The role of system approach in the application of economic-mathematical methods], Problemy razvitiia predpriatii: teoriia i praktika, Sbornik statei Mezhdunar. nauch.-prakt. konf. Penzenskii gosudarstvennyi universitet; Institut ekonomiki i upravleniia PGU; Mezhdunarodnaia akademiia organizatsii proizvodstva; Mezhotraslevoi nauchno-informatsionnyi tsentr; redaktor V.I. Budina, (2015) 50–56.
- [11] **Iu.B. Rishko, E.M. Malakhova**, Metody otsenki chelovecheskogo kapitala v organizatsii [Methods of evaluation of human capital in organizations], Vestnik Omskogo gosudarstvennogo agrarnogo universiteta, 4(16), (2014) 71–77.
- [12] **P.V. Romanteev**, Analiticheskii obzor metodik otsenki chelovecheskogo kapitala [Analytical review of methods of estimation of human capital], Ekonomika, predprinimatel'stvo i pravo, (2) (2011) 25–37.
- [13] **L.A. Strel'nikova**, Kluchevye kompetentsii kak osnova otsenki i razvitiia chelovecheskikh resurov mezhdunarodnykh kompanii [Key competences as a basis for assessment and development of human resources in international companies], Rossiia v global'nom mire. Sotsial'no-teoreticheskii al'manakh No. 1(24). Prilozhenie k zhurnalu dlia uchenykh «Klio», Izd-vo Politekhn. un-ta, St. Petersburg, (2013) 173–181.
- [14] **I.A. Toimentseva**, Priniatie upravlencheskikh reshenii na osnove ekonomiko-matematicheskikh metodov modelirovaniia v usloviakh neopredelennosti [Management decisions on the basis of economic-mathematical methods of modeling in conditions of uncertainty], Problemy ekonomiki i menedzhmenta, 11(15) (2012) 64–69.
- [15] **G.N. Tuguskina**, Otsenka stoimosti chelovecheskogo kapitala predpriatii [Valuation of human capital enterprises], Kadrovik. (11) (2009) 4–13.
- [16] **G.I. Khanin**, O sostoianii chelovecheskogo kapitala Rossii [On the state of human capital of Russia], Mirovaia ekonomika i mezhdunarodnye otnosheniia, 60 (9) (2016) 105–108.
- [17] **G.I. Khanin**, Ob otsenke ekonomiko-matematicheskikh metodov [On the evaluation of economic-mathematical methods], EKO, (4) (2010) 126–127.
- [18] **K.N. Khovanov**, Kompleks algoritmov generatsii kompozitsii dlia postroeniia sistem podderzhki priniatii reshenii [A set of algorithms for generating compositions for creation of system of support of decision-making]: dis. ... kand. tekhn. nauk, St. Petersburg, 2004. 180 p.
- [19] **A.S. Chevychelov**, Primenenie ekonomiko-matematicheskikh metodov v ekonomike, Obshchestvo, nauka i innovatsii [The use of economic-mathematical methods in Economics, Society, science and innovation], Sbornik statei Mezhdunar. nauch.-prakt. konf. Otv. red. A.A. Sukiasian, (2014) 154–156.
- [20] **M.S. Shumar**, Trebovaniya k chelovecheskomu kapitalu v sovremennykh usloviyakh [Requirements for human capital in modern conditions], Sovremenny menedzhment: problemy i perspektivy: sbornik, Izd-vo Sankt-Peterb. gos. ekon, un-ta, St. Petersburg, (2016) 108–113.

Strelnikova L.A. E-mail: larochkin@mail.ru

Lembrikova M.M. E-mail: m.lembrikova@gmail.com

СПИСОК ЛИТЕРАТУРЫ

- [1] **Алексеева Т.** Оцениваем уровень компетентности // Справочник по управлению персоналом. 2008. № 1. С. 64–71.
- [2] **Арабян К.К.** Оценка человеческого капитала : сб. докл. по итогам Всерос. науч.-практ. конф., Москва, 10–19 марта 2010 г. / под общ. ред. проф. О.Н. Мельникова. М.: Креативная экономика, 2010. С. 62–64.
- [3] **Басова А.Е., Шамигова А.С.** Человеческий капитал и инвестиции в человеческий капитал организации // Актуальные вопросы и перспективы науки и образования: матер. Междунар. заоч. науч.-практ. конф. Науч.-изд. центр «Мир науки», 2016. С. 61–64.
- [4] **Гречко М.В., Гончаров И.В.** Человеческий капитал, человеческие ресурсы, интеллектуальный капитал: взаимосвязь и различие категорий // Экономика и предпринимательство. 2016. № 2-2 (67-2). С. 243–249.
- [5] **Жук С.Н.** Оценка эффективности функционирования сложных систем по иерархической системе показателей // Труды СПИИРАН. 2013. Вып. 26. С. 194–203.
- [6] **Коваленко Е.В., Игнашкина И.В.** Оценка человеческого капитала сотрудника предприятия // Научно-методический электронный журнал «Концепт». 2015. Т. 13. С. 3171–3175.
- [7] **Носкова К.А.** Оценка человеческого капитала i-го сотрудника организации // Актуальные вопросы экономических наук: матер. II Междунар. науч. конф. (г. Уфа, апрель 2013 г.). Уфа: Лето, 2013. С. 4–8.
- [8] **Осадчая Н.А., Кравченко А.И.** Применение экономико-математических методов и моделей для оценки результативности кадрового потенциала строительной организации // Научное обозрение. 2013. № 12. С. 274–277.
- [9] **Пучков В.Ф., Грацинская Г.В.** Разработка и применение математических моделей для решения задач управления экономическими системами: моногр. М.: Изд. дом «БИБЛИО-ГЛОБУС». 416 с.
- [10] **Пушина Е.Г.** Роль системного подхода в применении экономико-математических методов // Проблемы развития предприятий: теория и практика: сб. статей Междунар. науч.-практ. конф. Пензенский государственный университет; Институт экономики и управления ПГУ; Международная академия организации производства; Межотраслевой научно-информационный центр; редактор В.И. Будина, 2015. С. 50–56.
- [11] **Ришко Ю.Б., Малахова Е.М.** Методы оценки человеческого капитала в организации // Вестник Омского государственного аграрного университета. 2014. Вып. 4(16). С. 71–77.
- [12] **Романтеев П.В.** Аналитический обзор методик оценки человеческого капитала // Экономика, предпринимательство и право. 2011. № 2. С. 25–37.
- [13] **Стрельникова Л.А.** Ключевые компетенции как основа оценки и развития человеческих ресурсов международных компаний // Россия в глобальном мире. Социально-теоретический альманах № 1(24). Приложение к журналу для ученых «Клио». СПб.: Изд-во Политехн. ун-та, 2013. С. 173–181.
- [14] **Тойменцева И.А.** Принятие управленческих решений на основе экономико-математических методов моделирования в условиях неопределенности // Проблемы экономики и менеджмента. 2012. № 11(15). С. 64–69.
- [15] **Тугускина Г.Н.** Оценка стоимости человеческого капитала предприятий // Кадровик. 2009. № 11. С. 4–13.
- [16] **Ханин Г.И.** О состоянии человеческого капитала России // Мировая экономика и международные отношения. 2016. Т. 60. № 9. С. 105–108.
- [17] **Ханин Г.И.** Об оценке экономико-математических методов // ЭКО. 2010. № 4. С. 126–127.
- [18] **Хованов К.Н.** Комплекс алгоритмов генерации композиций для построения систем поддержки принятия решений: дис. ... канд. техн. наук. СПб., 2004. 180 с.
- [19] **Чевычелов А.С.** Применение экономико-математических методов в экономике // Общество, наука и инновации: сб. статей Междунар. науч.-практ. конф. / отв. ред. А.А. Сукиасян, 2014. С. 154–156.
- [20] **Шумар М.С.** Требования к человеческому капиталу в современных условиях // Современный менеджмент: проблемы и перспективы: сборник. СПб.: Изд-во Санкт-Петербур. гос. экон. ун-та, 2016. С. 108–113.

Стрельникова Л.А. E-mail: larochkin@mail.ru

Лембрикова М.М. E-mail: m.lembrikova@gmail.com

Статья поступила в редакцию 17.02.17

DOI: 10.18721/JE.10209
UDC 339.144

THE HYBRID MODEL OF MULTIVARIATE INDEX ANALYSIS OF CURRENT ASSETS

A.N. Tsatsulin

North-West Institute of Management, St. Petersburg, Russian Federation

This article discusses the principles and methods of constructing a hybrid model for multivariate index analysis of the circulation of tangible assets on the example of retail trade enterprises. Analysis of the time and circulation velocity of the current assets was carried out with respect to the on-hand inventory for homogeneous positions of the group assortment of a shoe department of an economic entity. The time model and the turnover rate were built separately. At the final stage, applying the so-called index crossing procedure, the author constructed a \sqrt{t} -model, which contains five independent characteristic factors. Each of the considered characteristic factors corresponds to its standard statistical indicator, according to which the economic analysis is traditionally carried out depending on the formulated goals and tasks, both at enterprises and in special applied studies. The same factors serve as indicators of the financial performance of any economic entity, as comparative characteristics in assessing the subject's competitiveness in the commodity markets and can be used in assessing the market value of a business. The resulting model is verified, reliable calculations have been made for it. The model opens up new horizons for financial and economic analysis of the circulation of the company's tangible assets, allows to comprehensively study the parameters of velocity and time of commodity circulation. The latter is complicated, and sometimes even impossible at all, in econometric multifactor models due to multicollinearity of characteristic factors. This circumstance makes the future hybrid model constructed in the solution of problems of short-term forecasting and operational planning promising.

Keywords: simple index; analytical index; index crossing; mixed-index analysis; hybrid model of factor analysis; primary and secondary feature; working capital; current assets; index model

Citation: A.N. Tsatsulin, The hybrid model of multivariate index analysis of current assets, St. Petersburg State Polytechnical University Journal. Economics, 10 (2) (2017) 98–115. DOI: 10.18721/JE.10209

ГИБРИДНАЯ МОДЕЛЬ МНОГОФАКТОРНОГО ИНДЕКСНОГО АНАЛИЗА ОБОРОТНЫХ АКТИВОВ

А.Н. Цацулин

Северо-Западный институт управления Российской академии народного хозяйства и государственной службы при Президенте РФ, Санкт-Петербург, Российская Федерация

Рассматриваются принципы и методы построения гибридной модели многофакторного индексного анализа обращения материальных активов на примере запасов розничного торгового предприятия. Анализ времени и скорости движения оборотных средств проведен в отношении товарных запасов текущего хранения по однородным позициям группового ассортимента обувного отдела экономического субъекта. Отдельно построены модели анализа времени и скорости оборачиваемости изучаемых активов. На заключительном этапе с применением процедуры так называемого индексного кроссинга сконструирована \sqrt{t} -модель, которая содержит пять самостоятельных признаков-факторов. За каждым из учтенных признаков-факторов скрывается свой стандартный

статистический показатель, по которому традиционно осуществляется экономический анализ в зависимости от сформулированных целей и задач как на предприятиях, так и для специальных прикладных исследований. Эти же показатели являются индикаторами финансового состояния любого экономического субъекта, сравнительными характеристиками при оценке конкурентоспособности субъекта на товарных рынках и могут быть использованы при оценках рыночной стоимости бизнеса. Полученная модель верифицирована, по ней проведены достоверные расчеты. Модель открывает новые горизонты проведения финансово-экономического анализа движения материальных активов предприятия, позволяет воедино и комплексно изучать параметры скорости и времени товарного обращения. Последнее осложнено, а подчас бывает и вовсе невозможно в эконометрических многофакторных моделях в связи с явлением мультиколлинеарности признаков-факторов. Отмеченное обстоятельство делает перспективной построенную впервые подобную гибридную модель в решении задач краткосрочного прогнозирования и оперативного планирования.

Ключевые слова: простой индекс; аналитический индекс; индексный кроссинг; индексный микст-анализ; гибридная модель факторного анализа; первичный и вторичный признак; средства обращения; оборотные активы

Ссылка при цитировании: Цацулин А.Н. Гибридная модель многофакторного индексного анализа оборотных активов // Научно-технические ведомости СПбГПУ. Экономические науки. 2017. Т. 10. № 2. С. 98–115. DOI: 10.18721/JE.10209

«Well, in our country,» said Alice, still panting a little, «you'd generally get to somewhere else – if you run very fast for a long time, as we've been doing.»

«A slow sort of country!» said the Queen. «Now, here, you see, it takes all the running you can do, to keep in the same place. If you want to get somewhere else, you must run at least twice as fast as that!»

Carroll, Lewis: Through the Looking-Glass and What Alice Found There, Chapter 2

Introduction. Research in the field of industrial production, as well as in wholesale and retail trade touches upon issues of turnover of tangible assets which is a separate and important area of analysis of the financial condition of any economic subject. The effectiveness of such asset management is reflected immediately in terms of solvency and stability of the enterprise. There is considerable domestic and foreign bibliography dedicated to the study of time and the circulation velocity of certain types of tangible assets. This article is related to the construction of a fundamentally new hybrid $v|t$ -model of multivariate analysis on the example of the dynamics of asset inventory of a particular trader.

The indicators of the *time and velocity* of circulation of working capital are some of the most important and generalizing economic characteristics of the efficiency of circulation of the commodity mass in the form of raw materials, fuels, finished products, commodity reserves in the market space and of the

circulation within production cycles. These indicators generally serve such a special economic concept as *commodity turnover*.

The economic analysis of these characteristics is particularly important in setting conditions of the market mechanism of management of industrial enterprises of the real sector, sales, trading and purchasing of specialized applications and systems, improvement of commercial calculation and the increasing importance of financial leverage in diverse relationships with market partners [1; 2].

Formulation of the problem. Analysis of the time and the velocity of inventory circulation is included in the scheme of analysis of working capital, but it should be carried out taking into account the results directly analyzing the volume and structure of sales production and trade. Let us consider in more detail the measure to which commodity stocks secure the commodity turnover, i.e. The time of circulation of some fixed commodity mass, in order to build a multifactor index model for analyzing the circulation of the economic assets of the economic entity [3].

The indicator in the corresponding provision of i -th period is measured in days of turnover, i.e. the time of circulation of the j -th asset by the following relationship:

$$t_i^{(j)} = \overline{3_i^{(j)}} / \overline{W(1)_i^{(j)}}; \quad i = \overline{1, n}; \quad j = \overline{1, m}, \quad (1)$$

where $t_i^{(j)}$ – the spending time average stock, for example, normal sales process of goods in the days or time of circulation of goods; $\overline{3}_i^{(j)}$ – the average size of inventory in value during the reporting period, which is calculated as the average dynamic range of the torque on the observations of the state of inventory; $W(1)_i^{(j)}$ – the cost of one-day turnover of the j -th asset on the integrated heading, in the relevant currency units in the i -th period.

The index of turnover margin of security, or the measure of the time of circulation of goods, indicates the number of days of uniform sales that the actual size of the commodity stocks recorded and evaluated at the end of the reporting period, i.e., at a particular time or date, will be sufficient for. If you interpret the value of this indicator in terms of the circulation time of the goods, it characterizes the length of stay of the goods assortment of varieties in the form of a corresponding commodity stock. We calculate the value $t_i^{(j)}$ from Tab. 1 on the example of the company «Trading House» for the 3rd quarter of 2015, which will continue to

be regarded as a period. Preceding all subsequent analytical calculations, it is necessary to estimate the size of the average commodity stock for the 3rd quarter of the reporting period $\overline{3}_1^{(j)}$:

$$\overline{3}_1^{(j)} = \frac{0,5 \cdot 15\,600 + 12\,000 + 9\,600 + 0,5 \cdot 15\,900}{3} = 12\,450 \text{ thousand rub.} \quad (2)$$

Given that the turnover of one day in the 3rd quarter of 2015, i.e., the reporting period was 200 thousand rubles, the actual provision of turnover inventory was found to be in days

$$t_1^{(j)} = \frac{12\,450}{200} = 62.25 \text{ days.}$$

In this case, we can say with a known certainty that its enterprise standards of inventory are not fulfilled, because the time of its circulation of inventory amounted to only 62.25 days with easily defined regulatory circulation time:

$$t_{n_0}^{(j)} = \frac{\overline{3}_{n_0}^{(j)}}{W(1)_1^{(j)}} = \frac{15\,000}{200} = 75.00 \text{ days.} \quad (3)$$

Table 1

Calculation of deviations from the norm of inventory storage current j -th type retailer Limited Liability Company «Trading House» for the III quarter of 2015*

Order №	At the beginning of the month reporting year	Credited (planned) turnover for the quarter, ths. Rub.		The actual inventory of the current storage		Deviation from the norm		The actual turnover per month, ths. Rub.
		total	day turnover ИП ₃ /n _{pl} **	cost of, ths. Rub.	turnover in days	cost of, ths. Rub.	turnover in days	
$i = \overline{1, k}$	i	$W_{pl}^{(j)}$	$W(1)_{pl}^{(j)}$	$3_1^{(j)}$	$v_1^{(j)} = \frac{\overline{3}_1^{(j)}}{W(1)_{pl}^{(j)}}$	$\Delta 3_{1/n_0}^{(j)}$	$\Delta t_{1/n_0}^{(j)}$	$W(1)_1^{(j)}$
1	2	3	4	5	6	7	8	9
1	01.07.2015	×	×	15 600	78.00	600.00	3.00	5 850.00
2	01.08.2015	×	×	12 000	60.00	-3 000.00	-15.00	5 200.00
3	01.09.2015	×	×	9 600	48.00	-5 400.00	-27.00	6 900.00
4	The specification for the III quarter	18 000	200.00	15 000	75.00	×	×	17 950.00
5	01.10.2015	18 900	210.00	15 900	—	—	—	—

* Data source: the official state reporting data operational and technical and managerial accounting;

** Note: n_{pl} = 90 days.

Most often, in practice, when calculating this parameter, a one-day turnover of the reporting period, month or quarter, is taken as a denominator, and the actual commodity stocks at the end of the reporting period that will ensure the turnover of the upcoming period as a numerator.

So, for example, the security of commodity turnover in days under these conditions of the sales process for August ($i = 2$) turned out to be equal to

$$t_1^{(2j)} = \frac{3_1^{(2j)}}{W(1)_1^{(2j)}} = \frac{12\,000}{200} = 60.00 \text{ days.} \quad (4)$$

As seen from expression (4), the calculation of this parameter as the denominator is taken as the one-day turnover of the reporting period (month or quarter), as well as the numerator – the actual inventory at the end of the month in the reporting period, which will directly provide trade next month. Naturally, it is a complication that at the time when the index is calculated, the next analyzed one day turnover $W(1)_1^{(i)}$ is not yet known. Therefore, the actual turnover of preplanning period $W(1)_1^{(j)}$ is often taken in commercial practice. Index of turnover of inventory availability, in days, is determined by the individual products, product groups and as a whole.

Unequal turnover of tangible assets for selected groups of food and non-food items is primarily due to: the quality of goods, determining the nature of customer demand – daily, periodic, excessive; the complexity of the product portfolio; conditions for storage of inventory determined by the physicochemical properties of the goods; so a variety of food products require special storage conditions, which can be provided only in large enterprises, for example, or urban refrigeration chambers, vaults with special gas fillings, effective in the conditions of refrigerants and the use of modern innovative technologies [4].

Inventories turnover in days for a complex range of products, such as significant depth and breadth / width range, and durable, are generally much higher than for a simple range of goods and *FMCG* (*Fast Moving Consumer Goods*). Thus, food products of the so-called «Basic basket» of consumption (bread, milk, eggs, cheese, etc.), without which the trading network

cannot work (required, tie-in), have a transient turnover, in contrast to the products of the premium segment and the goods with a period of prolonged turnover (alcohol, confectionery and tobacco products and so on.).

The magnitude of the time of commodity circulation, both in the direction of acceleration and in the direction of its deceleration, and accordingly, the size of the commodity stock, is influenced by various factors that can be taken into account and, importantly, used in the inventory management system. Among the basic, fairly objective factors contributing to the reduction of the circulation time and, thus, the increase in the efficiency of trade, are such universal factors as the process of commodity distribution as general economic, industrial, trade and marketing.

The factors of general economic order should include political, social, legal and economic stability of the state, development of market structures, having a healthy competition among producers, suppliers and vendors, and as a consequence of the marked points – an increase in market supply of goods in accordance with the positive dynamics of solvent demand of the population as a whole and the individual consumer groups, in particular [5].

Production factors, such as the manufacture of printing book products, include the degree of conformity of print runs of books in the publication to customer demand. In the book market, this factor ultimately emerges as the changing ratio of the size of consumer demand for a specific product offering literature and adjusted the number of so-called «factories», i.e., publication issues within the general circulation.

Research methods. Analysis of the inventory of the current storage for example, by the trade organization, can be illustrated by the example shown in the Tab. 1 (columns 7–8). After analyzing the current inventory storage for the overall economic entity by comparing individual headings range. Research Methodology, used here by the author, is based on the technique of index analysis with the assistance of the First and Second Index systems, the development of which directly involved the works of authors [6–8].

The range of instruments used in the study includes the construction of simple and multivariate analytical indexes, with the release

of a result on the construction of the five-factor model, a hybrid of retail turnover. Author's model contains the analysis of the time factors, material assets turnover rate, size, inventory and analysis of two structural components with respect to the value of one-day sales and stock SKUs current storage company.

We consider the applied methodology. For each j -th commodity group it is determined by the size of the actual stock of the current storage at the beginning of the quarter, and in days of turnover. The value of the turnover indicator in days of turnover is obtained by dividing the total stock by the one-day planned, lending turnover of the new quarter for a particular commodity group:

$$t_1^{(ij)} = \frac{\overline{Z}_1^{(ij)}}{W(1)_1^{(ij)}}. \quad (5)$$

For July 2015, i.e. for the number $i = 1$ period of time, the stock circulation will be equal to

$$t_1^{(1j)} = 15\,600 / 200 = 78.0 \text{ days.}$$

Then, the value of $t_1^{(1j)}$ is compared with the value of $t_{n_0}^{(ij)}$, i.e. to the agreed norm or reference turnover.

In the event of significant changes in the actual structure of the turnover compared to a planned recalculation of sums standards for product groups, based on the actual size of turnover:

$$\Delta t_{1/n_0}^{(ij)} = t_1^{(ij)} - t_{n_0}^{(ij)}; \quad (6)$$

Let us say, for the points in time – July 2015 ($i = 1$)

$$\Delta t_{1/n_0}^{(1j)} = 78.0 - 75.0 = +3.0 \text{ days.} \quad (7)$$

Thus, the excess of inventory for the month turned out to be three days, and on the cost of the commodity mass excess was the same:

$$\begin{aligned} \overline{\Delta Z}_{1/n_0}^{(1j)} &= \Delta t_{1/n_0}^{(1j)} \cdot W(1)_1^{(ij)} = \\ &= 3.0 \cdot 200.0 = 600.0 \text{ thousand rub.} \end{aligned} \quad (8)$$

These estimates characterizing the excess of the normal level of monthly stocks can already serve in this form as valuable indicators of the inventory, even with very superficially conducted rapid analysis.

Analysis of the Speed circulation of inventory (ν -model). Analysis of the current inventory storage, one of whose tasks is to identify deviations of the actual stock on a specific date from the commodity standard of this period cannot be complete without examining the rate of turnover of tangible assets, which has independent significance.

Recall that the indicator already considered above for the asset or the time-reversal of inventory – is the term or period of time during which the average inventory is marketed. The faster the commercialized products are sold, the less working capital in the form of tangible assets is required for uninterrupted circulation process in trading systems, and the lower, hence, the distribution costs developing in trade and value chains.

Acceleration asset turnover, in turn, leads to a reduction the duration of the process of handling the material benefits in the form of a complete production and supply cycle, and, accordingly, to increase profitability, strengthen the financial condition of the company, etc. The indicator of inventory turnover security is closely related to the indicator of the *speed of circulation of commodities*, or the turnover of tangible assets having independent analytical value.

The rate of circulation of commodities, or *inventory turnover*, or even *the turnover speed* characterizes the number of revolutions of the mass of commodities, taken in the amount of the average commodity stock, which is calculated every time specifically for the analyzed period. The practical content of this characteristic can be interpreted as follows with the possible comment: how many times renewed commodity stock during the analyzed period, or sales occur during the reporting period in the amount of the average commodity stock.

The rate of turnover in the reporting period $\nu_1^{(ij)}$ is defined as a relative value by dividing the volume of trade on the average size of inventory for a particular i -th period and, preferably, on the integrated j -th commodity items with the following well-known relation:

$$\nu_1^{(ij)} = W_1^{(ij)} / \overline{Z}_1^{(ij)}, \quad (9)$$

where $W_1^{(ij)}$ – the value of the actual turnover for the period (quarter); $\overline{Z}_1^{(ij)}$ – the average inventory for the same period (quarter).

We perform speed calculation according to the same Tab. 1 for the period with the final counting of the column 9, in which the actual trade is shown in the amount of 17 950.0 thousand rubles. The velocity of the turnover for the quarter was, according to expression (9):

$$v_1^{(ij)} = 17\,950.0 / 12\,450.0 = 1.44 \text{ turnover.} \quad (10)$$

Thus, the mass of commodities is equal to the average commodity stocks, addressed during the period of about one and a half times. Knowing the speed of commodity circulation $v_1^{(ij)}$, can be determined during the already known circulation $t_1^{(ij)}$. For this purpose let us out a series of necessary identity transformations taking into account the meaning of the expression of formula (6):

$$v_1^{(ij)} = \frac{W_1^{(ij)}}{Z_1^{(ij)}} = \frac{W(1)_1^{(ij)} \cdot n_1}{Z_1^{(ij)}} = \frac{n_1}{t_1^{(ij)}}, \quad (11)$$

where n_1 – the number of days of operation of the enterprise in this quarter.

Location is determined by the time the average stock turnover rate through its characteristic

$$t_1^{(ij)} = n_1 / v_1^{(ij)} = 90.00 / 1.44 = 62.25 \text{ days.} \quad (12)$$

Consequently, the weight of tangible assets, equal to the average value of inventory addressed in the quarter of about 62.25 days – i.e. slightly more than the length of two full consecutive months.

In analyzing the dynamics of the rate of circulation of commodities and commodity-supply circulation time the index method is traditionally used which is a simple, clear, reliable and generally efficient comparison tool in conducting analytical calculations in the following areas: analysis of growth in turnover through faster turnover of goods; calculation of volume released (mobilized) or overly involved (immobilized) current assets as a result of the rate of change and the time of turnover of goods [9].

In order to illustrate these aspects of the example analysis of said range of footwear companies, which is listed in Tab. 2, should be to build the index dynamics of the average rate of turnover for the three k -th commodity items ($k = \overline{1, s}$) that are reflected in the table for the reporting and the base period. This measure of the average speed will be the index of variable

composition – characteristic of a productive attribute, the so-called First index system (1st IS):

$$\mathfrak{I}_{v(\bar{3}, v)_{1/0}} = \overline{\bar{3}_1 v_1^{(k)}} : \overline{\bar{3}_0 v_0^{(k)}} = \frac{\sum_{k=1}^s v_1^{(k)} \bar{3}_1^{(k)}}{\sum_{k=1}^s \bar{3}_1^{(k)}} : \frac{\sum_{k=1}^s v_0^{(k)} \bar{3}_0^{(k)}}{\sum_{k=1}^s \bar{3}_0^{(k)}}, \quad (13)$$

$v_0^{(k)} \Rightarrow v_1^{(k)}$
$Z_0^{(k)} \Rightarrow Z_1^{(k)}$

where $\overline{\bar{3}_1 v_1^{(k)}}$ – the average speed of the mass of commodities turnover in the reporting period specified in the Tab. 2 commodity groups of the shoe range, which can be estimated from the ratio of the final counting (FC) of columns 4 and 6 as FC_4/FC_6 :

$$\overline{\bar{3}_1 v_1^{(k)}} = \frac{\sum_{k=1}^s v_1^{(k)} \bar{3}_1^{(k)}}{\sum_{k=1}^s \bar{3}_1^{(k)}} = \frac{72\,570.0}{26\,620.0} = 2.726; \quad (14)$$

value $\overline{\bar{3}_0 v_0^{(k)}}$ – the average rate of the mass of commodities turnover in the corresponding reference period on the specified table in the same commodity groups of the shoe range, which can be estimated from the FC_3/FC_5 calculation:

$$\overline{\bar{3}_0 v_0^{(k)}} = \frac{\sum_{k=1}^s v_0^{(k)} \bar{3}_0^{(k)}}{\sum_{k=1}^s \bar{3}_0^{(k)}} = \frac{57\,690.0}{25\,260.0} = 2.284. \quad (15)$$

Finally, the very dynamics of the index of the average turnover rate, according to expression (13), was found to be

$$\mathfrak{I}_{v(3, v)_{1/0}} = \overline{\bar{3}_1 v_1^{(k)}} : \overline{\bar{3}_0 v_0^{(k)}} = 2,726 : 2,284 = \quad (16)$$

$v_0^{(j)} \Rightarrow v_1^{(j)}$	= 1,1935 ~ 119.35 %.
$Z_0^{(j)} \Rightarrow Z_1^{(j)}$	

Thus, the relative *growth rate of turnover* in the reporting period compared with baseline was 19.35 %. This increase occurred both through the growth of the actual speed rate (circulation of commodities) on all commodity positions range (see: Individual indices rate of commodity circulation in column 13 of Tab. 2), and due to changes in inventory structure for the same commodity items, that is, on the analyzed groups of shoes – leather, combined and sports (respectively, columns 9 and 10 of Tab. 2).

Table 2

The analysis of turnaround time of (*t*-model) and of turnover speed (*v*-model) material current assets in trade for the shoe department of Limited Liability Company «Trading House» for the III quarter of 2014–2015

Order №	Name of product group footwear	Quarterly volume of turnover by period, ths. Rub.		Individual quarterly turnover index	Average inventory on current storage periods, ths. Rub.		Individual index of inventories	Structure of average inventory for the period, %		The speed of turnover by period, time	
		basic	reported		basic	reported		basic	reported	basic	reported
$k = \overline{1, s}$	k	$W^{(k)}_0$	$W^{(k)}_1$	$i_{W_{1/0}}^{(k)} = \frac{W_1^{(k)}}{W_0^{(k)}}$	$Z^{(k)}_0$	$Z^{(k)}_1$	$i_{Z_{1/0}}^{(k)} = \frac{Z_1^{(k)}}{Z_0^{(k)}}$	$d_{Z_0}^{(k)} = \frac{Z_0^{(k)}}{\sum_{k=1}^s Z_0^{(k)}}$	$d_{Z_1}^{(k)} = \frac{Z_1^{(k)}}{\sum_{k=1}^s Z_1^{(k)}}$	$v^{(k)}_0$	$v^{(k)}_1$
1	2	3	4	5	6	7	8	9	10	11	12
1	Leather	24260.00	29820.00	1.2214	6990.00	6130.00	0.8770	27.67	23.03	3.47	4.86
2	Combined	21350.00	30640.00	1.4346	10100.00	12340.00	1.2218	39.99	46.36	2.11	2.48
3	Sports	12080.00	12110.00	1.0150	8170.00	8150.00	0.9976	32.34	30.61	1.48	1.49
—	In total:	57690.00	72570.00	1.2579	25260.00	26620.00	1.0538	100.00	100.00	2.284	2.726

Continuation of Tab. 2

Individual index of commodity circulation speed	The volume of trade turnover for the one-day period, ths. Rub.		Individual commodity mass index of a one-day turnover	The structure of the one-day turnover by period, %		Treatment in time periods, days		Individual index time reversal commodity weight
	basic	reported		basic	reported	basic	reported	
$i_{v_{1/0}}^{(k)} = \frac{v_1^{(k)}}{v_0^{(k)}}$	$W(1)_0^{(k)}$	$W(1)_1^{(k)}$	$i_{W(1)_{1/0}}^{(k)} = \frac{W(1)_1^{(k)}}{W(1)_0^{(k)}}$	$d_{W(1)_0}^{(k)} = \frac{W(1)_0^{(k)}}{\sum_{k=1}^s W(1)_0^{(k)}}$	$d_{W(1)_1}^{(k)} = \frac{W(1)_1^{(k)}}{\sum_{k=1}^s W(1)_1^{(k)}}$	$t_0^{(k)}$	$t_1^{(k)}$	$i_{t_{1/0}}^{(k)} = \frac{t_1^{(k)}}{t_0^{(k)}}$
13	14	15	16	17	18	19	20	21
1.4006	271.00	331.00	1.2214	42.28	41.07	25.79	18.52	0.7181
1.1754	237.00	340.00	1.4346	36.97	42.18	42.62	36.29	0.8515
1.0068	133.00	135.00	1.0150	20.75	16.75	61.43	60.37	0.9827
1.1935	641.00	806.00	1.2574	100.00	100.00	39.407	33.027	0.8381

In other words, the very average increment rate in the dynamics of expression (16) has taken place due to the simultaneous and combined effects of these two characteristic factors that should be resolved by the analyst into the individual components. Consequently, this increment should be decomposed into the factors noted specifically that will take into account their impact on the isolated change in the average characteristics of the velocity under the 1st IS.

The index scheme of factor analysis in this case can be constructed by decomposing an index of variable composition, which in a concrete situation is already essentially constructed and counted in the formulas from

expressions (13–16). But for the purposes of further analysis, this simple index of the variable structure is represented in its *modified form* as a record through the structural component – the stock share in columns 9 and 10 of Tab. 2.

$$\mathfrak{S}_{\bar{v}(d_{\bar{3},v})_{1/0}} = \frac{\sum_{k=1}^s d_{\bar{3}_1}^{(k)} v_1^{(k)}}{\sum_{k=1}^s d_{\bar{3}_0}^{(k)} v_0^{(k)}} \quad (17)$$

$\frac{d_{\bar{3}_0} \Rightarrow d_{\bar{3}_1}}{v_0 \Rightarrow v_1}$

In the aggregate index (17), all the values of the factors taken into account ($d_{\bar{3}}$ и v) change their value during the transition from reporting period to the base period. For this reason, we

should bear in mind that the index is called the index of variable composition of the resultant characteristic. In order not to clutter the calculation formulas, the overline over the analyzed characteristic factor $\overline{z_0^{(k)}}, \overline{z_1^{(k)}}$ serving as the characteristic of statistical averaging of the inventory over the corresponding headings will have to be omitted in the expressions below.

To assess the effect of turnover rate of individual commodity positions on the change in the average circulation velocity for the entire range of goods, it is necessary to build, within the framework of the 1st IS, analytical indices of permanent composition. Actually, this analytical index is built according to the rules for constructing a factor analytic index with weights of the corresponding period, taking into account the statistical nature of the indexed attribute [10]. In the specific case, the index of constant structure is constructed by the weights of the reporting quarter of 2015 with respect to a secondary sign, the circulation velocity of a commodity mass (v)

$$\mathfrak{S}_{v(v)1/0} = \frac{\overline{v_1^{(k)}}}{d_{31}} : \frac{\overline{v_0^{(k)}}}{d_{31}} = \frac{\sum_{k=1}^s v_1^{(k)} d_{31}^{(k)}}{\sum_{k=1}^s v_0^{(k)} d_{31}^{(k)}} = \quad (18)$$

$d_{31} = \text{const}$
$v_0 \Rightarrow v_1$

$$= \frac{2.726}{2.230} = 1.2224 \sim 122.24 \%$$

Thus, according to the results of calculations in expression (18), by increasing the velocity of the actual commodity weight for individual commodity groups, the average speed of the mass of commodities turnover increased in the reporting period compared to the base period by 22.24 %.

Next, you should find out how to affect change in the structure of inventory at an average speed of circulation of commodities. To this end, it is recommended to build the index of structural shifts or structure index

$$\mathfrak{S}_{v(d_3)1/0} = \frac{\overline{v_0^{(k)}}}{d_{31}} : \frac{\overline{v_0^{(k)}}}{d_{30}} = \frac{\sum_{k=1}^s v_0^{(k)} d_{31}^{(k)}}{\sum_{k=1}^s v_0^{(k)} d_{30}^{(k)}} = \quad (19)$$

$d_{30} \Rightarrow d_{31}$
$v_0 = \text{const}$

$$= \frac{2.230}{2.284} = 0.9764 \sim 97.64 \%$$

Calculations show that the decrease in the average turnover rate of 2.36 %, reflecting the

structure of index changes in expression (19), is due to a reduction in the proportion of the fastest on the winding assets against the share of growth relatively «slow» the winding assets (compare the decrease in the share of leather footwear and the increase in the proportion of shoes combined in rows 1, 2 in column 9). This brings to mind the quote from Carroll, quoted in an epigraph to the article, where there categories *Comparability*, *Relativity* are treated terminologically as extremely informative and very modern.

Of course, all built in (13-19) indexes, both simple and analytical, are algebraically linked together in the so-called First index system as follows

$$\mathfrak{S}_{v(d_3, v)1/0} = \mathfrak{S}_{v(d_3)1/0} \mathfrak{S}_{v(v)1/0} = \quad (20)$$

$$= 1.2224 \cdot 0.9764 = 1.1935 \sim 119.35 \%$$

Verification of calculations, of course, gives a numerical link for the built analytical indexes in said system in a relative way.

Built system indices can also be determined in accordance with the above trend analysis of the absolute amount of growth in turnover due to the acceleration of the turnover of individual products. This value is defined as the difference form of the index of constant composition formula of expression (18), presented in the aggregate form familiar for analytical indexes. Hence, the difference form of this index can be presented and calculated as

$$\Delta \sum_{k=1}^s W(v^{(k)})_{1/0} = \sum_{k=1}^s v_1^{(k)} d_{31}^{(k)} - \sum_{k=1}^s v_0^{(k)} d_{31}^{(k)} = \quad (21)$$

$$= 72\,570.00 - 59\,370.00 = 13\,200.00 \text{ ths. Rub.}$$

The resulting cost estimate of the increase of 13.2 million rubles can be attributed to the increase in turnover in the footwear group of goods achieved by the retailer in the reporting quarter as compared to the basic one due to the increase in the speed of turnover of tangible assets in the form of commodity stocks. In addition to the 1st IS, for the purpose of this analysis, the Second Index System (2nd IS), constructed on the direct characteristics of the statistical coupling, and also represented by three indices [11] can be used.

The index of permanent composition from expression (18) $\mathfrak{S}_{v(v)1/0}$ can also be found by

simple calculation in the framework of a direct characteristic of the statistical relationship by the following expression

$$\mathfrak{S}_{\bar{v}(v)}\% = \mathfrak{S}_{W(v,3)}\% : \mathfrak{S}_{W(3)}\%, \quad (22)$$

but as an analytical index of another index system, the 2nd IS.

The presented scheme of construction of the 1st and 2nd IS, followed by analytical calculations and comments reveal certain possibilities of deepening the detailed economic analysis of the characteristics of the retail turnover of the company investigated. Opening possibilities allow further discussion during case study material to build a more complex multivariate index structure in the form of analytical models involving, in addition to the characteristics of the turnover rate of current tangible assets (*v*), the characteristic time of their circulation (*t*).

The above is structurally loose material requires its logical conclusion in the form of a holistic copyright construct, based on the methodology adopted by the multivariate index analysis, which must be backed up by illustrative calculations on the raw data from Tab. 1 and 2, which will be demonstrated in the continuation of the article.

For the construction of the aforesaid models index methods of analyzing the dynamics of inventory homogeneous range were used with the assistance of the First (1st IS) and the Second index system (2nd IS). And if the first IS allows factor analysis with elements of degradation of resultant variable with respect to changes in the structure and composition of the assets, the second IS directs the analyst on the study of direct communication characteristics of statistical factors and their components.

In support of the above, let us once again get back to the first index system (1st IS), more precisely, to its resultant variable $W^{(k)}$, and apply the known analytical technique *replacing the secondary diagonal elements*. That is, known transformations are made over expression (13), which naturally do not change the essence of this equality itself

$$\begin{aligned} \mathfrak{S}_{\bar{v}(v,3)}\% &= \frac{\sum_{k=1}^s v_1^{(k)} \mathfrak{Z}_1^{(k)}}{\sum_{k=1}^s \mathfrak{Z}_1^{(k)}} : \frac{\sum_{k=1}^s v_0^{(k)} \mathfrak{Z}_0^{(k)}}{\sum_{k=1}^s \mathfrak{Z}_0^{(k)}} = \\ &= \frac{\sum_{k=1}^s v_1^{(k)} \mathfrak{Z}_1^{(k)}}{\sum_{k=1}^s v_0^{(k)} \mathfrak{Z}_0^{(k)}} : \frac{\sum_{k=1}^s \mathfrak{Z}_1^{(k)}}{\sum_{k=1}^s \mathfrak{Z}_0^{(k)}} = \mathfrak{S}_{W(v,3)}\% : \mathfrak{S}_{3}\%. \end{aligned} \quad (23)$$

The index of variable composition from the First index system was reduced, as shown in expression (23), to the ratio of two simple *dynamics indexes* of trade turnover and commodity stocks of current storage. But the thus obtained ratio is useful for the purposes of further deepening the factor analysis, and here it is permissible to use the analytical technique that allows due to differences in the two index systems to carry out a kind of factor complements. Such a technique may well be called *a crossing index*, or *the index of mixed analysis*.

Thus, on one hand, according to expression (20), the variable composition index $\mathfrak{S}_{\bar{v}(v^{(k)},3^{(k)})}\%$ is equal to the product of two factorial indices

$$\mathfrak{S}_{\bar{v}(d_3,v)}\% = \mathfrak{S}_{\bar{v}(d_3)}\% \times \mathfrak{S}_{\bar{v}(v)}\%, \quad (24)$$

and, on the other hand, the same index $\mathfrak{S}_{\bar{v}(d_3,v)}\%$, according to equation (23), coincides

with the following expression

$$\mathfrak{S}_{\bar{v}(d_3,v)}\% = \mathfrak{S}_{W(v,3)}\% : \mathfrak{S}_{3}\%. \quad (25)$$

Considering the last two entries (24) and (25) as a system of two equations with the same left-hand sides, let us solve them with respect to $\mathfrak{S}_{W(v,3)}\%$ as an unknown quantity index, placing the right side of the multiplier in a strictly meaningful sequence with the purpose of the circular linking of these indices in the shown pattern of expression (26).

Thus, in the course of transformation we obtained a 3-factor model of the volume index of turnover, depending on changes in the average inventory, changing its structure and changes in the average speed (rate) of its commodity circulation. This model can be called the *three-factor model* of trade analysis, depending on the state and dynamics of commodity stocks. In terms of content model must be «streamlined» as indicated in the scheme of logical and quantitative link located directly below expression (27).

$$\mathfrak{S}_{W(v,3)}\% = \mathfrak{S}_{\bar{v}(v)}\% \times \mathfrak{S}_{\bar{v}(d_3)}\% \times \mathfrak{S}_{3}\%, \quad (26)$$

Analysis of the circulation time (t-model) of tangible assets in the form of stock. Similar to the above analysis of the turnover rate, the circulation of inventory can be analyzed by the 1st IS scheme suitable for a homogeneous mix. However, here the pair of factors ($t(k)$, $W(1)(k)$) depending on each other determines as the multiplier the average size of the current storage stock ($Z(k)$). Needless to say, the calculations of factor influence are similar to the calculations for the analysis of asset turnover rate.

In particular, the modified index of variable composition from the 1st IS has the form that is easy to view and convenient for the purpose of factor analysis

$$\mathfrak{S}_{\overline{t(t^{(k)}, t_0^{(k)})}_{1/0}} = W(1)_1 \overline{t_1^{(k)}} : W(1)_0 \overline{t_0^{(k)}}, \quad (27)$$

where $W(1)_1 \overline{t_1^{(k)}}$ – the average handling time of inventory of current storage in the reporting period, which is calculated as the weighted arithmetic mean value, and as feature-weight in this calculation is the value of a one-day turnover in the reporting period – $W(1)_1^{(k)}$:

$$W(1)_1 \overline{t_1^{(k)}} = \frac{\sum_{k=1}^s t_1^{(k)} W(1)_1^{(k)}}{\sum_{k=1}^s W(1)_1^{(k)}} = \frac{26\,620.0}{806.0} = 33.027 \text{ days}; \quad (28)$$

value $W(1)_0 \overline{t_0^{(k)}}$ – average handling time of inventory of current storage in the base period, and it is estimated in the same prescribed manner, at the same time the one-day turnover of the reference period – $W(1)_0^{(k)}$ acts as the weight characteristic:

$$W(1)_0 \overline{t_0^{(k)}} = \frac{\sum_{k=1}^s t_0^{(k)} W(1)_0^{(k)}}{\sum_{k=1}^s W(1)_0^{(k)}} = \frac{25\,260.0}{641.0} = 39.407 \text{ days}. \quad (29)$$

Finally, the very dynamics of the index of the average time of circulation of inventory in accordance with expression (27), was found to be

$$\mathfrak{S}_{\overline{t(t^{(k)}, t_0^{(k)})}_{1/0}} = W(1)_1 \overline{t_1^{(k)}} : W(1)_0 \overline{t_0^{(k)}} = 33.027 : 39.407 = 0.8381 \sim 83.81\%. \quad (30)$$

Thus, due to the simultaneous and joint action of the two factors taken into account the average time of circulation of inventory decreased by 16.19 % in the reporting quarter compared to quarter basis. This means that if in 2014 the average current storage of inventory was enough without interruption in trade for 39.41 days, in 2015 it was only for 33.03 days, i.e., a difference of almost one week.

In other words, the average commodity stock in the last year turned into a realized turnover rate of approximately 6.4 days, or 153.6 hours, respectively, faster. This was the result of reducing the actual time reversal of inventory by individual commodity groups and items and changes in the structure of one-day sales of footwear in groups. Changes were noted in the reporting quarter compared to quarter basis in the respective years (see graphs 21 and 19–20 in Tab. 2).

The first circumstance (change time reversal) is reflected quantitatively in the index of constant composition of the following form specially constructed for this case

$$\mathfrak{S}_{\overline{t(t)_{1/0}}} = W(1)_1 \overline{t_1^{(k)}} : W(1)_1 \overline{t_0^{(k)}} = \frac{\sum_{k=1}^s t_1^{(k)} W(1)_1^{(k)}}{\sum_{k=1}^s W(1)_1^{(k)}} : \frac{\sum_{k=1}^s t_0^{(k)} W(1)_1^{(k)}}{\sum_{k=1}^s W(1)_1^{(k)}} = 33.027 : \frac{25.79 \cdot 331.0 + 42.62 \cdot 340.0 + 61.43 \cdot 135.0}{806.0} = 33.027 : \frac{31\,320.34}{806.00} = 33.027 : 38.859 = 0.8499 \sim 84.99\% \quad (31)$$

The second circumstance, namely, structural changes that have taken place, in turn, can be quantified by constructing an index structure of the changes in daily sales

$$\mathfrak{S}_{\overline{t(W(1))_{1/0}}} = W(1)_1 \overline{t_0^{(k)}} : W(1)_0 \overline{t_0^{(k)}} = \frac{\sum_{k=1}^s t_0^{(k)} W(1)_1^{(k)}}{\sum_{k=1}^s W(1)_1^{(k)}} : \frac{\sum_{k=1}^s t_0^{(k)} W(1)_0^{(k)}}{\sum_{k=1}^s W(1)_0^{(k)}} = 38.859 : 39.407 = 0.9861 \sim 98.61\% \quad (32)$$

The index indicates a decline in the average time of circulation of inventory by improving the day-sales structure: in particular, the proportion of third heading significantly decreased (from 20.65 % to 16.75 % – see graphs 16 and 17 in Tab. 2), in which the most significant circulation time was observed (see graph 19 in the same Tab. 2).

Naturally, all built indexes in (30)-(33) are linked to each other in the *First index system* through the multiplier analytical indexes

$$\mathfrak{I}_{\bar{t}, W(1)} \frac{1}{\%} = \mathfrak{I}_{\bar{t}(t)} \frac{1}{\%} \times \mathfrak{I}_{\bar{t}(W(1))} \frac{1}{\%} =$$

$\lambda^{(k)}_0 \Rightarrow \lambda^{(k)}_1$	$\lambda^{(k)}_0 \Rightarrow \lambda^{(k)}_1$	$\lambda^{(k)}_0 = \text{const}$
$W(1)^{(k)}_0 \Rightarrow W(1)^{(k)}_1$	$W(1)^{(k)}_1 = \text{const}$	$W(1)^{(k)}_0 \Rightarrow W(1)^{(k)}_1$

$$= 0.8499 \cdot 0.9861 = 0,8381 \sim 83,81 \%. \quad (33)$$

Verification in expression (33), of course, also gives a numerical linking in this case for the correctly pre-calculated indexes in a closed factor index system.

The constructed system of indices also allows to determine, in accordance with the direction of analysis of the use of current assets indicated above, the absolute amount of free working capital in the mode, for example, immobilization of assets due to a reduction in their circulation time. This sum is estimated using the difference form of an analytic constant index from expression (32)

$$\begin{aligned} \Delta \bar{3}(t) \frac{1}{\%} &= \sum_{k=1}^s \overline{3(t_1^{(k)})}_1 - \sum_{k=1}^s \overline{3(t_0^{(k)})}_1 = \\ &= \sum_{k=1}^s t_1^{(k)} W(1)_1^{(k)} - \sum_{k=1}^s t_0^{(k)} W(1)_1^{(k)} = \end{aligned} \quad (34)$$

$$= 26\,620.00 - 31\,320.34 = -4700.34 \text{ ths Rub.}$$

In terms of its economic content, the amount to be reduced in expression (34) is the value of the average inventories used in the reporting period, the conversion of which into the daily retail turnover occurred with the time actually spent per one turnover of the stock in the corresponding quarter of the reporting year. The subtrahend is the same conditional amount of working capital indicating how much current assets would be needed in 2015 if the time of circulation would be as large as originally, i.e., a year ago, as shown in expression (34).

The resulting «savings» (which has a negative sign) in the amount of more than 4.7 million rubles indicate the conditional value of immobilized assets. In other words, the volume of the free working capital was estimated as a result of a reduction in the time of the circulation of assets

in the channels of commodity circulation of the considered trading network.

Completing this section of the analysis of current assets, we can obtain another interesting derivative dependence of the analyzed indicators. To do this, it is necessary to repeat all the necessary algebraic transformations with the expressions used, which constitute the 1st IS. Namely: with the index of the variable composition of the average time of circulation of the commodity stock, depending on changes in the actual turnover time and the volume of one-day turnover.

It is appropriate to use the analytical technique that is already familiar, «replacement of the elements of the secondary diagonal» as the aggregate value of the ratio of two weighted average values of circulation time counted for dissimilar periods

$$\begin{aligned} \mathfrak{I}_{\bar{t}, W(1)} \frac{1}{\%} &= \frac{\sum_{k=1}^s t_1^{(k)} W(1)_1^{(k)} \cdot \sum_{k=1}^s t_0^{(k)} W(1)_0^{(k)}}{\sum_{k=1}^s W(1)_1^{(k)} \cdot \sum_{k=1}^s W(1)_0^{(k)}} = \\ &= \frac{\sum_{k=1}^s t_1^{(k)} W(1)_1^{(k)}}{\sum_{k=1}^s t_0^{(k)} W(1)_0^{(k)}} : \frac{\sum_{k=1}^s W(1)_1^{(k)}}{\sum_{k=1}^s W(1)_0^{(k)}} = \quad (35) \\ &= \mathfrak{I}_{\bar{3}(t, W(1))} \frac{1}{\%} : \mathfrak{I}_{W(1)} \frac{1}{\%}. \end{aligned}$$

Thus, the index of variable composition analysis of the average time of circulation of inventory of the current storage of the 1st IS in expression (27) proved to be reduced to, as shown in expression (35), with respect to the two simple indexes for average inventory of current storage and one-day turnover.

But the resulting ratio is definitely not the ultimate goal of the transformations done and is only an intermediate structure for the purpose of a more detailed study of the state and dynamics of current assets with the involvement of other optional examined similar analysis systems. It is also permissible to involve the already used technique of *index cross connection*, which allows to implement a kind of factorial addition due to differences in the analyzed attributes index systems.

So, on the one hand, according to expression (36), the variable composition index $\mathfrak{I}_{\bar{t}, W(1)} \frac{1}{\%}$ is equal to the product of two factor indices of circulation time and one-day turnover

$$\mathfrak{I}_{\bar{t}, W(1)} \frac{1}{\%} = \mathfrak{I}_{\bar{t}(t)} \frac{1}{\%} \cdot \mathfrak{I}_{\bar{t}(W(1))} \frac{1}{\%}. \quad (36)$$

On the other hand, the same index $\mathfrak{S}_{\bar{t},W(1)}\%$ in accordance with equation (35) coincides with the expression

$$\mathfrak{S}_{\bar{t},W(1)}\% = \mathfrak{S}_{\bar{3},W(1)}\% : \mathfrak{S}_{W(1)}\%. \quad (37)$$

Considering the last two entries in expressions (36) and (37) as a system of two equations with the same left-hand sides, we solve the system of equations for the index $\mathfrak{S}_{\bar{t},W(1)}\%$, taken as an unknown variable. Then place all the existing (pre-built) indices on the right side of the multiplier factor in a strictly meaningful sequence with the goal of linking these indices in the system.

In the cause and effect mechanism of statistical relations that has been updated in this way, the resultant factor, and in this case the primary indicator, is the index of the dynamics of average commodity reserves of the reporting period in comparison with the base period.

$$\mathfrak{S}_{\bar{3}(t,dW(1),W(1))}\% = \mathfrak{S}_{\bar{t}(t)}\% \times \mathfrak{S}_{\bar{t}(dW(1))}\% \times \mathfrak{S}_{W(1)}\%, \quad (38)$$

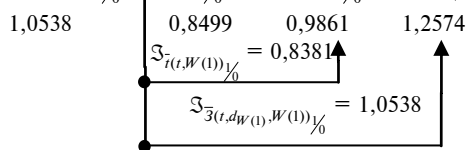

As a result of the transformations we obtained a three-factor index model of average inventory-dependent changes in the mean time reversal of inventory (\bar{t}), a one-day change in the structure of trade turnover ($dW(1)$) and the dynamics of one-day sales ($W(1)$).

This pattern of expression (38) can be called *three-factor t-model* analysis of average inventory, depending on the changes in the average time of circulation of assets, changes in one-day sales structure and dynamics of the one-day turnover. In terms of content and organizational terms the above-mentioned medium model of inventory of current storage must also be «ordered» or «linked» in a way that has already been used above, and as it is shown in the diagram, located directly under the multiplier from expression (38).

This ordering of the mechanism of the cause-and-effect relationships of the analyzed phenomenon allows the expert analyst to perform, in addition to analyzing the influence of the factors considered in relative form, an analysis of the influence of all the considered characteristic factors on the average size of the current stock and in absolute terms, which is extremely important in the operational work of the specialists of the enterprise.

The data from this example in Tab. 2 permit to conduct such analysis of the impact of factors taken into account in absolute terms by the example of the same shoe product groups. For this it is necessary to arrange the characteristic factors in the scheme of expression (38), starting with a *primary feature*, which is one-day trade $W(1)$, and further, in order of the content of their linkage in the index multiplier of the average inventory ($\bar{3}$), as shown in the scheme of expression (39).

We can then move on to the absolute level of characteristic factors, taking into account the indices already calculated and performing the calculations by the difference forms of the indices, using the method of *chain substitutions*.

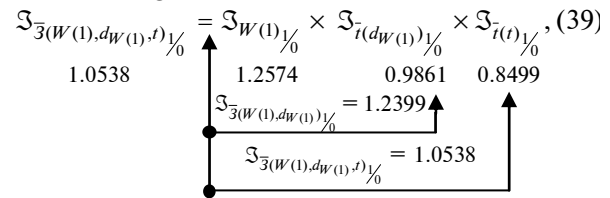

It follows from the calculations by the scheme in expression (39) that due to a change in the structure of one-day sales (-1.39%), the mean inventory increased by 23.99% . But due to the reduction of the time reversal of this reserve at 15.01% , the increase in the average stock of goods necessary for the reporting period was limited to only 5.38% compared to the baseline.

Let us estimate the change in absolute terms due to the influence of each of the three characteristic factors taken into account. The total deviation of inventory due to the cumulative effect of all the factors is:

$$\begin{aligned} \Delta \sum_{k=1}^s \bar{3}(W(1), dW(1), \bar{t})\% &= \sum_{k=1}^s \bar{3}(W(1), dW(1), \bar{t})_1 - \\ &- \sum_{k=1}^s \bar{3}(W(1), dW(1), \bar{t})_0 = 26\,620.0 - 25\,260.0 = \quad (40) \\ &= 1360.0 \text{ thsRub.} \end{aligned}$$

The impact of one-day sales in the amount of inventories was equal to

$$\begin{aligned} \Delta \sum_{k=1}^s \bar{3}(W(1))_{1/0} &= \sum_{k=1}^s \Delta W(1)_{1/0}^{(k)} dW(1)_{1/0}^{(k)} \bar{t}_0^{(k)} = \\ &= (806.0 - 641.0)[0.4255 \cdot 25.79 + \\ &+ 0.3680 \cdot 42.62 + 0.2065 \cdot 61.43] = \quad (41) \\ &= 165.0[10.97 + 15.678 + 12.69] = \\ &= 165.0 \cdot 39.34 = 6491.1 \text{ ths Rub.} \end{aligned}$$

Influence of the structure of one-day sales in the amount of inventories in absolute terms is estimated as follows:

$$\begin{aligned} \Delta \sum_{k=1}^s \bar{3}(d_{W(1)})_{1/0} &= \sum_{k=1}^s W(1)_1^{(k)} \Delta d_{W(1)}^{(k)} \bar{t}_0^{(k)} = \\ &= 806,0 [(0,4107 - 0,4255)25,79 + \\ &+ (0,4218 - 0,3680)42,62 + (0,1675 - \\ &- 0,2065)61,43] = 806,0[-0,3817 + \\ &+ 2,2930 - 2,3958] = \\ &= 806,0(-0,4845) = -390,51 \text{ ths Rub.} \end{aligned} \quad (42)$$

Effect of changes in commodity-supply circulation time by the amount of stock in absolute terms is estimated as follows:

$$\begin{aligned} \Delta \sum_{k=1}^s \bar{3}(\bar{t})_{1/0} &= \sum_{k=1}^s W(1)_1^{(k)} d_{W(1)}^{(k)} \Delta \bar{t}^{(k)}_{1/0} = \\ &= 806,0[0,4107(18,52 - 25,79) + \\ &+ 0,4218(36,29 - 42,62) + 0,1675(60,37 - \\ &- 61,43)] = 806,0(-2,9858 - 2,6700 - \\ &- 0,1776) = -4701,72 \text{ ths Rub.} \end{aligned} \quad (43)$$

The control counting check of the balance of the factorial influences (increments) for the change in the size of the commodity stock in the reporting period in comparison with the base period gives the amount of the total increment from expression (40) with reservations regarding the possible acceptable rounding errors. All partial factorial increments can, if necessary, for the sake of clarity, be consolidated into a single standard analytical table.

The results of research. In this article the author presents the conceptual hybrid $v|t$ -model of multivariate analysis (velocity-time), allowing to explore the phenomenon of turnover of tangible assets of the economic entity in more detail.

Using the index schemes from expressions (25) and (38), we can easily obtain the analytical relations that allow both indexes of variable composition and three simple indexes of the dynamics of commodity turnover, dynamics of average commodity stocks and dynamics of one-day sales to be integrated into a single index scheme. A resultative characteristic of the linear dependence (direct characteristic of the statistical connection) of all indices in the form of a multiplier is the index of the dynamics of

retail turnover, which depends on the factors that are taken into account in the relative analysis of the characteristic factors according to the rules of the following *five-factor model*

$$\begin{aligned} \mathfrak{S}_{W\%} &= \mathfrak{S}_{v(v)\%} \times \mathfrak{S}_{v(3)\%} \times \mathfrak{S}_{t(t)\%} \times \mathfrak{S}_{t(d_{W(1)})\%} \times \mathfrak{S}_{W(1)\%} \cdot \\ 1,2579 &\begin{array}{l} \uparrow \\ \mathfrak{S}_{v(v)\%} = 1,1935 \\ \mathfrak{S}_{v(3)\%} : \mathfrak{S}_{3(W(1))\%} = 1,0144 \\ \mathfrak{S}_{W\%} : \mathfrak{S}_{W(1)\%} = 1,0003 \\ \mathfrak{S}_{W\%} = 1,2579 \end{array} \begin{array}{l} \uparrow \\ 1,2224 \\ 0,9764 \\ 0,8499 \\ 0,9861 \\ 1,2574 \end{array} \end{aligned} \quad (44)$$

While *quantitative linkage* of all indices into a system directly characterizing the link does not cause technical difficulties, the economical connection of each step with a characteristic factor (change in retail turnover) is not always obvious. Here the expert analyst should exercise patience in building a causal chain of interconnected features, in searching for the necessary links of this chain with the real indicators attached to them, and, finally, to carry out a thorough interpretation of the results obtained successively. This is extremely important and is connected, first of all, with the fact that the factors included in the hybrid model are controllable, they can be predicted and planned in the orientation to final financial and economic results.

Bearing in mind the analysis of the absolute influence of the factors taken into account on a productive feature (in this case – the amount of retail goods turnover), the starting index of the chain in the formula of expression (44) should be the primary composite index only for its statistical nature trait-factor on the right side of the multiplier. He is a simple index of the dynamics of one-day sales – $\mathfrak{S}_{W(1)\%}$.

The next element of the chain linking «begs» to be an index that contains, at least in the numerator or the denominator, the aggregate characteristic of one-day sales volumes throughout the shoe assortment. That index is the index of one-day sales structure – $\mathfrak{S}_{t(d_{W(1)})_{1/0}}$. Therefore, by carefully calibrating the meaningful economic aspect of the method of chain substitutions, you can build the required analytical chain indices in a strictly specified sequence recorded below by the scheme from expression (45).

$$\begin{aligned}
 \mathfrak{S}_{W(W(1), \bar{t}(d_{W(1)}, t(t), \bar{v}(d_3), \bar{v}(v)))_{1/0}} &= \mathfrak{S}_{W(1)_{1/0}} \times \mathfrak{S}_{\bar{t}(d_{W(1)})_{1/0}} \times \mathfrak{S}_{\bar{t}(t)_{1/0}} \times \mathfrak{S}_{\bar{v}(d_3)_{1/0}} \times \mathfrak{S}_{\bar{v}(v)_{1/0}} \\
 1,2579 & \quad \quad \quad 1,2574 \quad 0,9861 \quad 0,8499 \quad 0,9764 \quad 1,2224 \\
 \mathfrak{S}_{\bar{t}(d_{W(1)})_{1/0}} &= 1.2399 \\
 \mathfrak{S}_{\bar{t}(t)_{1/0}} &= 1.0538 \\
 \mathfrak{S}_{\bar{v}(d_3)_{1/0}} &= 1.0289 \\
 \mathfrak{S}_{W(W(1), \bar{t}(d_{W(1)}, t(t), \bar{v}(d_3), \bar{v}(v)))_{1/0}} &= 1.2579
 \end{aligned} \tag{45}$$

As a control test is necessary to carry out an algebraic coherent meaningful linkage of each of the index built into the hybrid v/t -model (velocity-time) of turnover of tangible assets represented by the formula of expression (45) one by one, moving phases of this scheme in the direction of the left – right:

We carry out a second factor linking the analytical index of expression (45) in the scheme of the index multiplier model. The second account is the index of the influence of the structure on the daily sales average time of circulation of the current inventory storage – $\mathfrak{S}_{\bar{t}(d_{W(1)})_{1/0}}$. The product of the first pair of indices gives the following interesting and understandable analytical dependence

$$\begin{aligned}
 \mathfrak{S}_{W(1)_{1/0}} \times \mathfrak{S}_{\bar{t}(d_{W(1)})_{1/0}} &= \\
 \frac{W(1)_0 \Rightarrow W(1)_1}{\begin{matrix} d_{W(1)_0} \Rightarrow d_{W(1)_1} \\ t_0 = \text{const} \end{matrix}} &= \\
 = \frac{\sum_{k=1}^s W(1)_1^{(k)}}{\sum_{k=1}^s W(1)_0^{(k)}} \times \left[\frac{\sum_{k=1}^s t_0^{(k)} W(1)_1^{(k)}}{\sum_{k=1}^s W(1)_1^{(k)}} \cdot \frac{\sum_{k=1}^s t_0^{(k)} W(1)_0^{(k)}}{\sum_{k=1}^s W(1)_0^{(k)}} \right] &= \tag{46} \\
 = \frac{\sum_{k=1}^s t_0^{(k)} W(1)_1^{(k)}}{\sum_{k=1}^s t_0^{(k)} W(1)_0^{(k)}} = \mathfrak{S}_{\bar{t}(d_{W(1)})_{1/0}} & \quad \quad \quad \frac{d_{W(1)_0} \Rightarrow d_{W(1)_1}}{t_0 = \text{const}}
 \end{aligned}$$

As a result of the transformations in expression (46), we obtained an analytical index of commodity stock, depending on changes in the structure of one-day sales $\mathfrak{S}_{\bar{t}(d_{W(1)})_{1/0}}$. The

next (third in a row) factorial analytical index in the formula of expression (45), which is to be linked to the multiplier circuit, is the index of constant composition, the average time of inventory turnover – $\mathfrak{S}_{\bar{t}(t)_{1/0}}$ of course, affecting

the size of the average stocks of this storage. We show below the necessary transformations

$$\begin{aligned}
 \mathfrak{S}_{\bar{t}(d_{W(1)})_{1/0}} \mathfrak{S}_{\bar{t}(t)_{1/0}} &= \frac{\sum_{k=1}^s t_0^{(k)} W(1)_1^{(k)}}{\sum_{k=1}^s t_0^{(k)} W(1)_0^{(k)}} \times \frac{\sum_{k=1}^s t_1^{(k)} W(1)_1^{(k)}}{\sum_{k=1}^s t_0^{(k)} W(1)_1^{(k)}} = \\
 &= \frac{\sum_{k=1}^s t_1^{(k)} W(1)_1^{(k)}}{\sum_{k=1}^s t_0^{(k)} W(1)_0^{(k)}} = \mathfrak{S}_{\bar{t}(d_{W(1), t)_{1/0}}} = \mathfrak{S}_{\bar{t}(t)_{1/0}}.
 \end{aligned} \tag{47}$$

Next, it is necessary to implement the linkage of the multiplier of the fourth component (the index of the change in the average rate of turnover of tangible assets due to a structural shift in the composition of commodity stocks) into the scheme. Here the result of the previous link of the index $\mathfrak{S}_{\bar{t}(t)_{1/0}}$, i.e.

a simple index of expression (47) should be multiplied by an analytical index $\mathfrak{S}_{\bar{v}(d_3)_{1/0}}$. Each time, the procedure of circular linking of indices into the system should be carefully guided by the rules for constructing the index scheme, the economic content of the technical and economic indicators, and by carefully carrying out the necessary transformations in the aggregate parts of the conjugate factorial analytic indices. Let us implement these recommendations with respect to the following scheme:

$$\begin{aligned}
 \mathfrak{S}_{\bar{t}(t)_{1/0}} \mathfrak{S}_{\bar{v}(d_3)_{1/0}} &= \frac{\sum_{k=1}^s t_1^{(k)} W(1)_1^{(k)}}{\sum_{k=1}^s t_0^{(k)} W(1)_0^{(k)}} \times \\
 & \times \left[\frac{\sum_{k=1}^s v_0^{(k)} \mathfrak{S}_1^{(k)}}{\sum_{k=1}^s \mathfrak{S}_1^{(k)}} \cdot \frac{\sum_{k=1}^s v_0^{(k)} \mathfrak{S}_0^{(k)}}{\sum_{k=1}^s \mathfrak{S}_0^{(k)}} \right] = \frac{\sum_{k=1}^s \mathfrak{S}_1^{(k)} v_0^{(k)}}{\sum_{k=1}^s \mathfrak{S}_0^{(k)} v_0^{(k)}} = \mathfrak{S}_{W(\bar{3})_{1/0}}.
 \end{aligned} \tag{48}$$

The analytical index of the dynamics of retail turnover obtained in expression (48) depends on the change in the structure of the commodity stock by assortment positions. And, finally, the last, fifth factor influencing the size of the commodity stock, which is also subject to linkage in the index scheme of the multiplier of the relative effect on the volume of retail turnover of shoes is the analytical index of constant composition of inventory velocity – $\mathfrak{S}_{\bar{v}(v)}\%_0$. It should «agree» with the previous result in the form of turnover changes index depending on changes in the value of inventory of current storage – $\mathfrak{S}_{W(3)}\%_0$.

$$\begin{aligned} \mathfrak{S}_{W(3)}\%_0 \mathfrak{S}_{\bar{v}(v)}\%_0 &= \frac{\sum_{k=1}^s v_0^{(k)} \mathfrak{Z}_1^{(k)} \sum_{k=1}^s v_1^{(k)} \mathfrak{Z}_1^{(k)}}{\sum_{k=1}^s v_0^{(k)} \mathfrak{Z}_0^{(k)} \sum_{k=1}^s v_0^{(k)} \mathfrak{Z}_1^{(k)}} = \\ &= \frac{\sum_{k=1}^s v_1^{(k)} \mathfrak{Z}_1^{(k)}}{\sum_{k=1}^s v_0^{(k)} \mathfrak{Z}_0^{(k)}} = \frac{\sum_{k=1}^s W_1^{(k)}}{\sum_{k=1}^s W_0^{(k)}} = \mathfrak{S}_{W(\bar{3},v)}\%_0. \end{aligned} \quad (49)$$

We should draw attention to the fact of the ‘seemingly’ automatic refinement of the location of primary and secondary factors ($W(1)^{(k)}, d_W^{(k)}, t^{(k)}, d_3^{(k)}, v^{(k)}$) in the corresponding intermediate chain links of the hybrid $v|t$ -model up to the resultant variable factor – W from expression (49). However, this apparently natural simplicity is established by the analyst in advance, with the preliminary selection of the factors taken into account and aligning the interrelated indicators into meaningful chains.

Conclusions. As a result of the subject study, a hybrid index model was constructed for analyzing the value of the quarterly commodity turnover, which depends on the quantity of the stock of current storage and on the volume of daily sales. The economic sense of the final result of the transformations from expression (49), which is fairly transparent to the reader, allows managers handling the logistical and marketing business processes of production, trade, wholesale and retail enterprises to establish standards of on-hand inventory.

With this approach, it is also possible to make timely adjustments to these standards, both taking into account the intensity of daily sales,

and taking into account the precisely estimated seasonal factor of purchases and sales. Thus, even taken separately but in a row and in a pairs, the analytical indices provide economically understandable and transparent results in the process of linkage, provided that the actual factor scheme in the multiplier of the direct characteristic of the statistical linkage is previously sufficiently verified.

The semantic analysis scheme, represented by separate expressions (47) and (49), can be interestingly interpreted as a constructed group of analytic indices evaluating the «dual structural shift» that occurred, firstly, as part of the commodity stock that ensures the turnover of the reported period, due to the change in the structure of the company’s daily sales of shoes. This apparently unfavorable structural shift was the reason for another shift, which already happened in the range of sales for the analyzed period. This second circumstance, as a result, led to a slight increase by only 1.44 % in retail turnover in the reporting period compared to the base one (compared to the previous growth rate of +19.35 % by the formula from expression (44)) in the calculations by the analytical chain.

In fact, the first structural shift in the assessment of significant symptoms caused the second structural shift of another, no less significant feature similar to the movement of geologic plates or reservoirs under tectonic phenomena. The proposed model allows the author to simultaneously and jointly explore and speed, and time of turnover of tangible assets with respect to typical primary reporting indicators and standard indicators of economic activity of the economic entity.

The hybrid model provides a reliable estimate of the factor-based influences on the resultant indicator and, accordingly, the circular balance linkage of the factorial increments not only in a relative form, but also in absolute terms, i.e., by cost, applying the first-difference method as a particular case of the method of chain substitutions with respect to dynamics, the planned task, and the level of the plan. Tab. 3 shows the magnitudes of the absolute effect of each of the five characteristic factors on the volume of quarterly retail turnover, as well as the values of these increments in comparison with both the overall increase (row 6) and in comparison with the base level of the resultant indicator (row 7).

Table 3

Summary description of the analysis of the dynamics of material circulating assets of retailer Limited Liability Company «Trading House»

Order №	Factor name, which has been taken into account	Unit measurement	Contingent designations	Impact in absolute terms, Rub.	Relative deviation, % to	
					the total change	the level of the base period
$k = \overline{1, K}$	x_k	module	$\Delta W(x_k)_{1/0}$	$\Delta W(x_m)_{1/0} = x_{11}x_{21}\dots x_{m1/0}\dots x_{k0}$	$\frac{\Delta \sum_{j=1}^m W(x_k^{(j)})_{1/0}}{\Delta \sum_{j=1}^m W(x_1, x_2, x_3, x_4, x_5)_{1/0}}$	$\frac{\Delta \sum_{j=1}^m W(x_k^{(j)})_{1/0}}{\sum_{j=1}^m W_0^{(j)}}$
1	2	3	4	5	6	7
1	The volume of one-day sales	Rub. per day	$\Delta W(W(1))_{1/0}$	15 043 700.13	101.10	26.08
2	The structure daily sales average time of treatment of the current inventory storage	days	$\Delta W(\bar{t}(d_{w(1)}))_{1/0}$	-3 008 815.39	-20.22	-5.22
3	The average stock turnover time	days	$\Delta W(\bar{t}(t))_{1/0}$	-6 073 615.21	-40.82	-10.53
4	Change in the average rate of in-inventory turnover due to a structural shift	speed for the period	$\Delta W(\bar{v}(d_3))_{1/0}$	-4 374 671.48	-29.39	-7.58
5	The average velocity of circulation of inventory	speed for the period	$\Delta W(\bar{v}(v))_{1/0}$	13 293 401.95	89.33	23.04
—	In total:	Rub.	$\Delta W(x_1, x_2, x_3, x_4, x_5)_{1/0}$	14 880 000.00	100.00	25.79

Summary. Of course, the above scheme of factor analysis based on the hybrid index model is not the only possible one. There are other, equally interesting schemes for conducting the economic analysis of the state and dynamics of current assets with a different set of factors that characterize the level of commodity stocks from different standpoints and from other aspects, not necessarily using the index method, but also methods of correlation and regression analysis, as well as other analytical techniques with a more complex mathematical apparatus, say, using matrix methods of research [12], etc.

The direction of future research. Nevertheless, in view of the considerations presented in the

two-part article, it seems very promising to use the hybrid $v|t$ -model in integrated systems for the complex analysis of the financial and economic state of an economic entity, along with, say, coefficient analysis and multi-factor forecasting models for predicting bankruptcy. The definite possibilities offered by the author of the model for the purpose of adjusting the state accounting (financial) reporting of the enterprise are of particular interest in cases when reasonable management decisions need to be made for the enterprise, in assessing the market value of businesses, and also in providing the technology for operational and long-term planning [11].

REFERENCES

[1] A.N. Tsatsulin, Osobennosti formirovaniya sprosa v ramkah noviyh form trgovli [The Peculiarities of demand in the new forms of trade], Materialiy respublikanskogo sovetzhanija-seminara «Sovershenstvovanie rabotiy po izucheniyu sprosa v

noviyh usloviyah hoziystvovaniya», Cheliyabinsk, Izd-vo VNIKS MT RSFSR, Moscow, (1988) 50–53.

[2] A.N. Tsatsulin, A.V. Babkin, Analysis of the Structural Components and Measurement of the Effects of Cost Inflation in the Industry with the Help

of the Index Method, Proceedings of the 28th International Business Information Management Association Conference 9–10 November 2016 Seville, Spain. Vision 2020: Innovation Management, Development Sustainability, and Competitive Economic Growth, Editor Khalid S. Soliman, International Business Information Management Association (IBIMA) 1559–1573.

[3] **G.I. Baklanov**, Nekotorye voprosy indeksnogo metoda [Some questions of an index method], Statistics, Moscow, 1972. 346 p.

[4] **A.N. Tsatsulin**, Upravlenie zatratami na predpriyatii [Management of expenses at the enterprise]. Educational and methodical complex. Direction of education: 08.02.00.62 «Management». Qualification (degree) of the graduate bachelor, Baltiiskaya akademiya turizma i predprinimatel'stva [Baltic academy of tourism and business], St. Petersburg, 2014. 112 p.

[5] **B.G. Ploshko**, Gruppировка i sistemy statisticheskikh pokazatelei. Indeksy [Grouping and systems of statistics. Indexes], Statistics, Moscow, 1971. 177 p.

[6] **R. Alan**, Ekonomicheskie indeksy [Economic indexes]. Translation from English. Statistics, Moscow, 1980. 324 p.

[7] **L.S. Kazinets**, Tempy rosta i strukturnye sdvigi v ekonomike (pokazateli planirovaniya i statistiki) [Growth rates and structural shifts in economy (indicators of planning and statistics)], Economy, Moscow, 1981. 184 p.

[8] **V.E. Adamov**, Factor index analysis (Methods and problems), Statistics, Moscow, 2012. 200 p.

[9] **A.N. Tsatsulin**, On the construction of the index analysis model of material current assets in trade, Belgorod University of cooperation, economics and law – HERALD, (2016) 3(59) 113–128.

[10] **A.N. Tsatsulin**, Analiz sostoyaniya tovarnykh zapasov s pomoshch'yu indeksnykh skhem [The analysis of a condition of commodity stocks by means of index schemes], Sovershenstvovanie optovoi trgovli tovarami narodnogo potrebleniya [Improvement of wholesale trade in consumer goods], Materialy nauchno-tehnicheskoi konferentsii, Under edition of N.P. Goncharov, Knowledge, St. Petersburg (1989) 52–59.

[11] **A.N. Tsatsulin**, Ekonomicheskii analiz [Economic analysis]. The textbook for higher education institutions, Izd-vo SZIU RANKhiGS, St. Petersburg, 2012. 924 p.

[12] **E.I. Maksimenko**, Matematicheskie metody kontrollinga. gosudarstvo i biznes: sovremennye problem ekonomiki [Mathematical methods of controlling. Government and business: current issues in Economics], Materialy VIII mezhdunarodnoj nauchno-prakticheskoy konferentsii, SZIU, St. Petersburg, (4) (2016) 65–70.

[13] **J. Mackevius, O. Molien, D. Popkait**, Benendrojo pardavimo elningumo kompleksinis analizis metodika, Ekonomika, 25 (8) (2008) 74–90.

[14] **R.A. David, J.S. Dennis, A.W. Thomas**, Statistics for business and economics, Mason, USA, Thomson Higher Education, Thomson South-Western, 2006. 1010 p.

Tsatsulin A.N. E-mail: vash_64@mail.ru

СПИСОК ЛИТЕРАТУРЫ

[1] **Цацулин А.Н.** Особенности формирования спроса в рамках новых форм торговли: матер. республиканского совещания-семинара «Совершенствование работы по изучению спроса в новых условиях хозяйствования», г. Челябинск. М.: Изд-во ВНИИКС МТ РСФСР, 1988. С. 50–53.

[2] **Tsatsulin A.N., Babkin A.V.** Analysis of the Structural Components and Measurement of the Effects of Cost Inflation in the Industry with the Help of the Index Method. Proceedings of the 28th International Business Information Management Association Conference 9–10 November 2016 Seville, Spain. Vision 2020: Innovation Management, Development Sustainability, and Competitive Economic Growth // Editor Khalid S. Soliman, International Business Information Management Association (IBIMA). Pp. 1559–1573.

[3] **Бакланов Г.И.** Некоторые вопросы индексного метода. М.: Статистика, 1972. 346 с.

[4] **Цацулин А.Н.** Управление затратами на предприятии. Учебно-методический комплекс. Направление подготовки: 08.02.00.62 «Менедж-

мент». Квалификация (степень) выпускника бакалавр / Балтийская академия туризма и предпринимательства. Санкт-Петербург, 2014. 112 с.

[5] **Плошко Б.Г.** Группировка и системы статистических показателей. Индексы. М.: Статистика, 1971. 177 с.

[6] **Алан Р.** Экономические индексы: пер. с англ. М.: Статистика, 1980. 324 с.

[7] **Казинец Л.С.** Темпы роста и структурные сдвиги в экономике (показатели планирования и статистики). М.: Экономика, 1981. 184 с.

[8] **Адамов В.Е.** Факторный индексный анализ (Методика и проблемы) / под ред. В.Е. Адамова. М.: Статистика, 2012. 200 с.

[9] **Цацулин А.Н.** О построении индексных моделей анализа материальных оборотных активов в торговле // Международный научно-теоретический журнал «Вестник Белгородского университета кооперации, экономики и права». Серия «Экономические науки». 2016. № 3(59). С. 113–128.

[10] **Цацулин А.Н.** Анализ состояния товарных запасов с помощью индексных схем // Совершен-



ствование оптовой торговли товарами народного потребления: матер. науч.-техн. конф. / под ред. П.Г. Гончарова. СПб.: Знание, 1989. С. 52–59.

[11] **Цацулин А.Н.** Экономический анализ: учебник для вузов. СПб.: Изд-во СЗИУ РАНХиГС при Президенте РФ, 2012. 924 с.

[12] **Максименко Е.И.** Математические методы контроллинга. Государство и бизнес: современные проблемы экономики: матер. VIII Меж-

дунар. науч.-практ. конф. Т. 4. СПб.: СЗИУ, 2016. С. 65–70.

[13] **Mackevius J., Molien O., Popkait D.** Benendrojo pardavimo elningumo kompleksinis analizis metodika // *Economika*. 2008. Vol. 25. No. 8. Pp. 74–90.

[14] **David R.A., Dennis J.S., Thomas A.W.** Statistics for business and economics. Mason, USA : Thomson Higher Education / Thomson South-Western, 2006. 1010 p.

Цацулин А.Н. E-mail: vash_64@mail.ru

Статья поступила в редакцию 12.02.17

Научное издание

**НАУЧНО-ТЕХНИЧЕСКИЕ ВЕДОМОСТИ САНКТ-ПЕТЕРБУРГСКОГО ГОСУДАРСТВЕННОГО
ПОЛИТЕХНИЧЕСКОГО УНИВЕРСИТЕТА. ЭКОНОМИЧЕСКИЕ НАУКИ**

ST. PETERSBURG STATE POLYTECHNICAL UNIVERSITY JOURNAL. ECONOMICS

Том 10, № 2, 2017

Учредитель – Федеральное государственное автономное образовательное учреждение высшего образования
«Санкт-Петербургский политехнический университет Петра Великого»

Журнал зарегистрирован Федеральной службой по надзору в сфере информационных технологий и массовых коммуникаций
(Роскомнадзор). Свидетельство о регистрации ПИ № ФС77-52146 от 11 декабря 2012 г.

Р е д а к ц и я

д-р экон. наук, профессор *В.В. Глухов* – председатель редколлегии,
д-р экон. наук, профессор *А.В. Бабкин* – зам. председателя редколлегии,
Н.А. Теплякова – редактор,
А.А. Родионова – технический секретарь,
А.С. Колгатина – редактор-лингвист

Телефон редакции 8(812)297–18–21

E-mail: economy@spbstu.ru

Компьютерная верстка *Е.А. Корнуковой*

Лицензия ЛР № 020593 от 07.08.1997 г.

Подписано в печать 28.04.2017. Формат 60×84 1/8. Бум. тип. № 1.
Печать офсетная. Усл. печ. л. 14,5. Уч.-изд. л. 14,5. Тираж 1000. Заказ

Санкт-Петербургский политехнический университет Петра Великого.
Издательство политехнического университета,
член Издательско-полиграфической ассоциации университетов России.
Адрес университета и издательства: 195251, Санкт-Петербург, ул. Политехническая, д. 29.

УСЛОВИЯ ПУБЛИКАЦИИ СТАТЕЙ

в журнале «Научно-технические ведомости Санкт-Петербургского государственного политехнического университета. Экономические науки»

ОБЩИЕ ПОЛОЖЕНИЯ

Журнал «Научно-технические ведомости Санкт-Петербургского государственного политехнического университета. Экономические науки» является периодическим печатным научным рецензируемым изданием. Зарегистрировано Федеральной службой по надзору в сфере информационных технологий и массовых коммуникаций (Роскомнадзор). Свидетельство о регистрации ПИ № ФС77-52146 от 11.12.2012 г. С 2008 года выпускался в составе сериального периодического издания «Научно-технические ведомости СПбГПУ» (ISSN 1994-2354).

Издание с 2002 года входит в Перечень ведущих научных рецензируемых журналов и изданий (перечень ВАК) и принимает для печати материалы научных исследований, а также статьи для опубликования основных результатов диссертаций на соискание ученой степени доктора наук и кандидата наук по следующим основным научным направлениям: Менеджмент, Макроэкономика, Мировая экономика, Региональная экономика, Экономика и менеджмент предприятия, Маркетинг, Финансы, Бухгалтерский учет, Налогообложение, Управление инновациями и др. Научные направления журнала учитываются ВАК Минобрнауки РФ при защите докторских и кандидатских диссертаций в соответствии с Номенклатурой специальностей научных работников.

Сведения о публикации представлены в РИНЦ Реферативном журнале ВИНТИ РАН, в международной справочной системе «Ulrich's Periodical Directory».

Периодичность выхода журнала – шесть номеров в год.

ПРАВИЛА ДЛЯ АВТОРОВ

Требования к оформлению статей

1. Рекомендуемый объем статей 12–20 с. формата А4 с учетом графических вложений. Количество графических вложений (диаграмм, графиков, рисунков, фотографий и т. п.) – не более шести.

2. Авторы должны придерживаться следующей обобщенной структуры статьи: вводная часть 0,5–1 с. (актуальность, существующие проблемы); основная часть (постановка и описание задачи, изложение и суть основных результатов); заключительная часть 0,5–1 с. (выводы, предложения); список литературы, оформленный по ГОСТ 7.05–2008.

3. Число авторов статьи не должно превышать трех.

4. Набор текста осуществляется в редакторе MS Word, формулы – в редакторе MS Equation или MythType. Таблицы набираются в том же формате, что и основной текст.

Шрифт: гарнитура Times New Roman, размер шрифта – 14 п. Таблицы большого размера могут быть набраны 12 кеглем. Поля: слева – 3 см, сверху и снизу – 2,5 см, справа – 2 см. Текст без переносов. Межстрочный интервал – 1,5. Текст выравнивается по ширине полосы. Абзацный отступ 1 см.

5. Рисунки, таблицы, фотографии размещаются по тексту статьи.

Требования к представляемым материалам

Для опубликования статьи в журнале «Научно-технические ведомости Санкт-Петербургского государственного университета. Экономические науки» вместе с материалами статьи должны быть представлены:

- аннотация на русском и английском языках;
- ключевые слова (пять-семь) на русском и английском языках;
- для статей аспирантов или соискателей ученой степени кандидата наук – заверенная в отделе кадров рекомендация научного руководителя, отражающая актуальность, значимость, ценность и новизну полученных результатов. В качестве выводов необходимо указать, что статья может быть рекомендована для опубликования в журнале «Научно-технические ведомости СПбГПУ. Экономические науки», Научный руководитель несет ответственность за содержание статьи, достоверность представленных материалов.

С авторами статей заключается издательский лицензионный договор.

Представление всех материалов осуществляется через Электронную редакцию.

Рассмотрение материалов

Представленные материалы (см. требования) первоначально рассматриваются редакционной коллегией и передаются для рецензирования. После одобрения материалов, согласования различных вопросов с автором (при необходимости) редакционная коллегия сообщает автору решение об опубликовании статьи или направляет автору мотивированный отказ.

При отклонении материалов из-за нарушения сроков подачи, требований по оформлению или как не отвечающих тематике журнала материалы не публикуются и не возвращаются.

Редакционная коллегия не вступает в дискуссию с авторами отклоненных материалов.

Публикация научных статей в журнале осуществляется на безвозмездной основе, независимо от места работы автора.

При поступлении в редакцию значительного количества статей их прием в очередной номер может закончиться ДОСРОЧНО.

Более подробная информация размещена на сайте: ntv.spbstu.ru

Для получения справочной информации обращайтесь в редакцию:

8(812)297-18-21 с 10⁰⁰ до 18⁰⁰ Анна Андреевна,
или по e-mail: economy@spbstu.ru

