



DOI: 10.18720/MCE.96.3

Building energy modeling using hourly infiltration rate

I.Yu. Bilous*, V.I. Deshko, I.O. Sukhodub

National Technical University of Ukraine “Igor Sikorsky Kyiv Polytechnic Institute”, Kyiv, Ukraine

* E-mail: bilouys_inna@ukr.net

Keywords: buildings, energy efficiency, ventilation, air exchange rate, temperature, heating

Abstract. In Eastern Europe countries, including Ukraine, a significant part of the buildings belongs to the mass development of the 80s, which are characterized by a low level of energy efficiency. For such countries with sharply continental climates, heating costs prevail to a large extent. Improved thermal protection forces more attention to be paid to heat losses with ventilation. The distribution of air exchange between individual rooms is difficult to determine, especially due to natural ventilation. The work is devoted to considering the conditions of natural convection and determining the effect on the energy consumption of a building. The article considers the advanced ASHRAE technique for calculating natural air exchange. The influence of the temperature and wind characteristics of the outdoor air on the natural component of the air exchange rate at the different locations of the representative rooms of an 8-story building is analyzed. The value of the air exchange rate for typical conditions of Kiev does not exceed 0.25 h⁻¹, 0.65 h⁻¹ and 0.4 h⁻¹ for two-chamber and single-chamber double-glazed windows, triple glazing in wooden double binders, respectively. On the first floors, air exchange is associated with air infiltration, and on the last floors there is exfiltration, which must be taken into account when dynamically modeling the energy characteristics of a building. The example is with additional mechanical ventilation to maintain a comfortable environment. 5R1C dynamic grid models were created to study the energy performance of the building. The estimate of additional heating costs due to infiltration is 23 % for the North and 43 % for the South orientation of rooms with two-chamber energy-saving windows. It has been established that in dynamics, the energy consumption of a building with normative air exchange and the calculated value of the *natural component differs by 50–75 %*, which is a possible level of savings under actual air exchange conditions in comparison with standard ones. This savings can be reduced by increasing air exchange during busy hours, for example, due to additional aeration.

1. Introduction

HVAC systems are designed to maintain the thermal comfort and quality of the indoor climate. The HVAC systems usually have a large percentage of the total energy cost in the building. In developed countries this figure can be about 40%, for post-Soviet countries this figure is over 40 %. [1] Considering global trends aimed at reducing energy consumption and greenhouse gas emissions, software for modeling energy processes in a building is used to deepen the analysis of energy consumption, allowing to consider different design and operation options [2, 3].

In the European area of the post-Soviet countries, including Ukraine, a large part of buildings belongs to the typical construction of the 80-ies, which is characterized by low energy efficiency. The energy performance of these buildings is influenced by the thermophysical properties of the envelope, geometry, solar heat gains and additional internal heat gains, air exchange rate and operating conditions. Effect of innovative energy-saving measures on building envelope and heat sources is investigated in detail in papers [4, 5]. One of the most influential parameters is the air exchange rate [6, 7]. Energy need calculations based on dynamic modeling are carried out using such software products as EnergyPlus (37 %), TRNSYS (35 %), DOE-2 (16 %) and others [8].

For buildings of 70–80's typical development in the post-Soviet countries the low level of thermal insulation properties of building enclosures is typical. For the proper functioning of such buildings, the significant part of energy costs is used for heating (for Eastern European countries heating period lasts for about six months). The trends of the last decades are aimed at improving the thermal insulation properties of



building enclosures. For instance, according to the standard of Ukraine [9], with regard to the recommendations of the energy saving measures implementation priority, the main attention is paid to the measures for thermal renovation of the building envelope and heating system regulation. After the introduction of energy saving measures (the first stage), the ventilation component of heat loads in residential and commercial buildings can range from 25 to 50% [9]. In order to ensure proper working environment from the air exchange point of view, the specified air exchange rate is regulated in the standards. In buildings, the air exchange rate is provided in two ways: naturally and mechanically. In most of the old Soviet buildings of typical construction mechanical ventilation is not provided or is not working.

For buildings in Eastern Europe after thermo-modernization the component of ventilation losses significantly increases in the overall energy balance of building losses. At the same time, improving the thermal performance of windows results in a reduction in air exchange through natural ventilation. Features of energy-saving measures implementation in Ukraine follow the general trends in Central and Western Europe, where after the implementation of measures associated with improvement of building envelope thermophysical properties, the CO₂ concentration in premises with natural ventilation has increased significantly [10]. Reducing this component is the second step in implementing energy-saving measures in Ukraine. Therefore, in the context of widespread implementation of programs aimed at increasing the thermal protective properties of the building envelope, greater attention should be paid to factors influencing natural ventilation (free convection).

Recent studies have confirmed this need and paid considerable attention to air exchange research [11, 12]. Studies [13] have shown that the most influential parameter on the energy balance of a building is the air exchange rate. For example, infiltration share in France can be 15%. In the USA researchers conclude that this component reaches 33 %. [14]

It is difficult to determine the real value of air exchange rate in spaces. A number of scientific studies are devoted to the determination of this parameter using experimental approach based on measuring the CO₂ concentrations [10, 15–18] but it requires a large number of representative spaces and experimental studies.

Accurate consideration of the infiltration component is the key to the reliability and quality of the calculations to determine the feasibility of implementing energy-saving measures. The calculation of natural ventilation is based on the use of physical and empirical models [19]. Physical models for determining natural air exchange are quite complex and require a large number of output parameters, which significantly complicates the calculation for buildings with many zones. These approaches use algebraic equations that relate characteristics of the building, such as height, orientation, air permeability of building envelope, and weather conditions. One of the first approaches was developed by Shaw and Tamura [20], which was based on a single equation that combined the stack and wind effect to calculate the natural air exchange rate.

Empirical approaches have been reflected in software for calculating the energy performance of buildings. Among the most widely used software complexes for energy modeling of buildings are: eQuest (17 %), EnergyPlus (12 %), TRNSYS (8 %), DOE2 (8 %), DesignBuilder (6 %), and Ecotect Analysis (5 %) [19]. It should be noted that the general capabilities of airflow modeling in the above software systems are based on empirical equations to determine infiltration designed for residential buildings based on ASHRAE approaches and cannot be applied to taller buildings or buildings with natural or mechanical ventilation systems. Therefore, a number of empirical methods for determining air exchange that are reflected in software can be used for low-rise residential buildings [21–23].

More recently proposed method of estimating infiltration in commercial buildings using EnergyPlus [24] considers wind, not just temperature effects [20, 25]. This approach is based on the use of constant coefficients *A*, *B*, *C*, *D* for DOE-2 and BLAST methodology (formula 1) [24].

$$\text{Infiltration} = I_{design} \cdot F_{schedule} [A + B \cdot \Delta T + C \cdot W + D \cdot W^2], \quad (1)$$

where I_{design} is defined by EnergyPlus as the "design infiltration rate", which is the airflow through the building envelope under design conditions; $F_{schedule}$ is a factor between 0.0 and 1.0 that can be scheduled, typically to account for the impacts of fan operation on infiltration [24]; ΔT is the indoor-outdoor temperature difference, °C; W is the wind speed in m/s. It should be noted that EnergyPlus varies the outdoor temperature and wind speed by zone height for use in Equation (1) and for other calculations. How this was handled in this study is detailed in Ng et al. [26]. *A*, *B*, *C*, and *D* are constants, for which values are suggested in the EnergyPlus user manual [24]. Two sets of values are presented: DOE-2 and BLAST.

However, as mentioned above, this approach (the considered coefficients) describes with sufficient accuracy the processes of air exchange only in low-rise buildings. In addition, the method provides a simplified picture of the impact of building envelope air permeability, weather and HVAC system operation on infiltration rate [26]. The method [24] does not allow to consider the wind direction and height, which is especially important for the leeward and windward facades of the building.

One of the software used for the analysis of air flows in buildings is CONTAM [26]. CONTAM is a multi-zone computer program for air quality and ventilation analysis that allows determining infiltration, exfiltration and airflows into rooms from controlled mechanical ventilation systems, wind pressures acting on the exterior surfaces of a building, the stack effect caused by the difference in indoor and outdoor air temperatures, concentrations of pollutants and their effects on humans. It should be noted that this software product is used at the design stage and has not found its application in the energy management of existing buildings.

The software complexes discussed above allow for an hourly change in weather data based on typical meteorological year (TMY) data [26, 27].

For Ukraine and other post-Soviet countries, with a respect to improving the energy efficiency of typical development buildings, the assessment of the baseline level of energy consumption when implementing a set of energy-saving measures is one of the key issues. In calculations of the baseline level of energy consumption, air exchange rate is taken in accordance with the normative values [28], and its actual value is difficult to determine experimentally, given that the natural component of this parameter has a dynamic nature.

When calculating the buildings energy performance in Ukraine using stationary and quasi-stationary methods, the climatic characteristics for the respective regional center are used, namely, the monthly average outside temperature, solar heat gains on the horizontal and vertical surfaces for the quasi-stationary method, the average values for the heating period are used for heating degree-day method [1]. The impact of the wind in the models for the monthly and seasonal averaging intervals is considered by the normative value of the air exchange rate.

In terms of efficient energy use (heating system regulation) the energy need for heating should be calculated on the basis of hourly changing climatic characteristics [1]. In Ukraine, dynamic models for determining the buildings energy performance [1], which require the use of hourly climate data, such as International Weather for Energy Calculations (IWEC) file, are becoming increasingly widely used [27]. Similar approaches are relevant both for the design and in-depth analysis of the energy performance of existing buildings, and the climatic conditions of Ukraine are similar for the countries of Central and Eastern Europe (Ukraine, Baltic States, Belarus, Hungary, Poland, Czech Republic, Slovakia, Western Russia).

The analysis shows that the empirical methods for calculating the natural air exchange rate are quite simple, but usually can be used only for low-rise buildings or partially account for influential parameters on the air exchange rate in buildings. Software-based mathematical models for determining the natural air exchange rate allow the calculation of air exchange rate by zone and are commonly used at the design stage, and have not been widely used in energy consumption regulation. There is a need to develop empirical methods that can be easily used and accurately describe the actual natural air exchange for existing housing stock of buildings.

With the described problems, there is a need for improved empirical methods for determining the air exchange in buildings, which are simpler than models based on physical modeling, but at the same time allow to calculate for multi-story buildings in conditions of operation, considering the time variability of weather conditions, which will allow for a more detailed calculation of the baseline level of energy consumption.

The aim of the paper is to develop approaches to the in-depth analysis and specification of air exchange rates in the context of dynamic change of environmental characteristics for the existing building stock of post-Soviet countries, based on the climate characteristics of Kyiv, Ukraine. Objectives of the study are to:

1. provide a generalized methodology for determining the calculated value of the air exchange rate;
2. develop a mathematical model of local determination of the air exchange rate in multi-story buildings;
3. carry out a comparative analysis of the air exchange rate for different values of air permeability for climatic data of a typical year meteorological file IWEC [27];
4. show the importance of influential parameters with the help of air exchange rate modelling and to evaluate its influence on the change of energy need local characteristics.

2. Methods

Usually, mathematical models for determining buildings energy consumption use the value of the air exchange rate for ventilation component (air exchange). Air exchange is difficult to determine experimentally. Even with the same window designs in terms of air permeability, different amounts of air enter the room. Room air exchange depends on a number of factors, both external and internal ones. The generalization of the methods for air exchange rate determination based on the calculation of pressure differences given in the studies of Berge A. and others [30, 31] and according to the ASHRAE approaches [21] is used in the paper, which allows to use the given technique for multi-story buildings. The pressure difference that determines the air exchange rate in a building is created by three different mechanisms: stack effect, wind pressure effect, forced ventilation effect (Fig. 1) and is calculated as their sum (formula 2):

$$\Delta P_{tot} = \Delta P_s + \Delta P_w + \Delta P_v = \Delta P_{inf} + \Delta P_v, \quad (2)$$

ΔP_{tot} is total pressure difference, Pa;

ΔP_s is pressure difference from stack effect, Pa;

ΔP_w is the wind pressure difference, Pa;

ΔP_v is pressure difference from forced ventilation, Pa;

ΔP_{inf} is infiltration pressure difference, Pa.

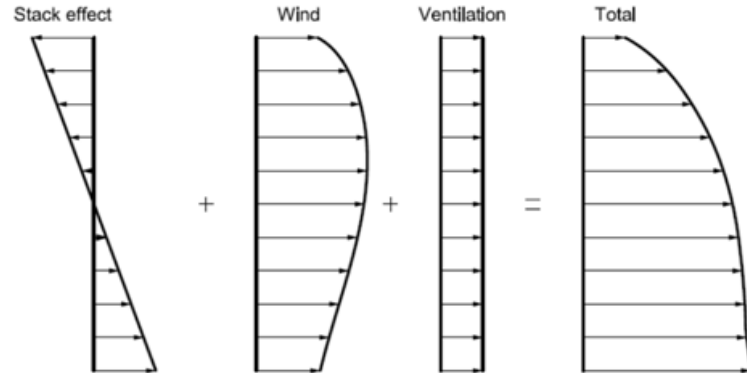

Figure 1. Example of building height distribution and sum of pressure difference profiles [31].

The stack effect is also called the buoyancy effect created by the difference in density between warm and cold air. Reduction of air pressure with the height determined by the formula (3):

$$\Delta P_s = P_e(z) - P_i(z) = z(\rho_e - \rho_i)g, \quad (3)$$

z is height from the reference point, m;

ρ_e, ρ_i are density of exterior and interior air, kg/m^3 ;

g is acceleration of gravity, m/s^2 .

From the neutral pressure level towards the first floor, the pressure difference is positive, towards the last floor it is negative. Assuming that air is the ideal gas, formula (3) looks like:

$$\Delta P_s = 3456 \cdot z \left(\frac{1}{T_e} - \frac{1}{T_i} \right), \quad (4)$$

T_e, T_i are exterior and interior air temperature, respectively, K.

Wind pressure is created when airflow hits an obstacle. The magnitude of the wind pressure depends on the wind speed and direction (windward, leeward side, etc.).

Most software products for modeling wind pressure, use the following formula [30, 31, 7]:

$$\Delta P_w = \frac{\rho U_{met}^2}{2} C_h C_p(\theta), \quad (5)$$

ρ is density of the environment air, kg/m^3 ;

U_{met} is wind speed according to the nearest weather station, m/s;

$C_p(\theta)$ is wind pressure factor considering wind direction through the angle of incidence θ ;

θ is the magnitude of the wind angle relative to the normal drawn to the considered surface, $^\circ$;

C_h is wind pressure factor that considers the height.

$$C_h = \frac{U_H^2}{U_{met}^2} = A_0^2 \left(\frac{H}{H_{ref}} \right)^{2a}, \quad (6)$$

U_H is wind speed at the highest point of the object, m/s;

A_0 is the wind shelter coefficient; [20]

H is height of the considered floor of the building from the ground level, m;

H_{ref} is height at which the weather station measures wind speed, m;

a is an exponential coefficient that considers wind shelter for a given area [30].

The amount of air entering the room due to leakage under the specified conditions (without mechanical ventilation) is determined by the following formula:

$$G_{inf} = C(\Delta P_{inf})^p \text{ or } G_{inf} = \frac{\Delta P_{inf}^p}{R_b} F_w \quad (7)$$

G_{inf} is the amount of air entering the room due to leakage, kg/h;

C, p are coefficient and the degree index depend on the purpose of the building;

R_b is window air permeability resistance, $(m^2 \cdot h \cdot Pa^{2/3})/kg$ [32];

F_w is window area, m^2 .

The space air exchange rate as a characteristic of the ventilation node in mathematical models is determined by the following formula [32]:

$$n = \frac{G_{inf}}{\rho V}, \quad (8)$$

V is volume of the space, m^3 ;

n is air exchange rate, h^{-1} .

The above method allows to consider the infiltration and exfiltration flows into the space, which significantly affects the energy performance characteristics.

Model description. For the purpose of building energy performance study, a group of representative premises having southern and northern orientation was considered with the thermophysical properties of building envelope for typical construction: 1) triple glazed windows in PVC profiles; 2) triple glazing in wooden twin sashes; 3) double glazing in wooden twin sashes (old translucent structures). The building has 8 floors, where the constant indoor air temperature of 18°C is maintained during the heating period. Based on the selected representative premises (on the 1st, 3rd, 6th floor with southern and northern orientation), a study of the change in the air exchange rate in a multi-story building with different types of windows permeability was carried out according to the above described method. The hourly values from the IWEK file for the climatic conditions of Kyiv (Ukraine) [27] were used: dry bulb temperature, wind speed and direction, barometric pressure.

3. Results and Discussion

3.1. Calculation of hourly natural air exchange in accordance with IWEK climate data of a typical year

The climate file IWEK [27] shows hourly values for wind speed and direction. Wind direction is given in degrees clockwise starting from north (0°).

From the analysis of the IWEK file for Kyiv city (Ukraine) of [27], it follows that the most typical wind direction for the cold season is northern and northwestern, and the average speed is 2.7 m/s, which is similar to the data of building climatology of Ukraine for the given region. [29]. The range of fluctuations of hourly values of wind speed is from 0 m/s to 18 m/s (rarely). The wind direction changes every two hours on average.

According to IWEK, the average outdoor air temperature for the heating season is 1.7 °C, which is slightly different from the current climatology [29] value of -0.1 °C. The minimum external temperature in the IWEK file occurs in February and is -15.8 °C. Regular changes in average daily outside air temperature can be up to 4 °C, and fluctuations within the day can be up to 5 °C. The behavioral trends of daily, between-day and seasonal temperature fluctuations are similar for those of Central and Eastern Europe.

Given that the hourly data for a typical year gives 8760 points, for each point there is a complex effect of a number of factors. Therefore, the impact has been explored alternately to separation the impact of change in outside temperature, wind speed and direction on the value of in pressure difference from wind and stack

effect. The considered range of change in outside temperature, wind speed and direction may be relevant for other climatic zones.

Fig. 2 presents the height profiles of pressure difference caused by the stack effect, depending on the change in ambient temperature. This phenomenon is related to the difference in density between warm and cold air and does not depend on the orientation of the premise.

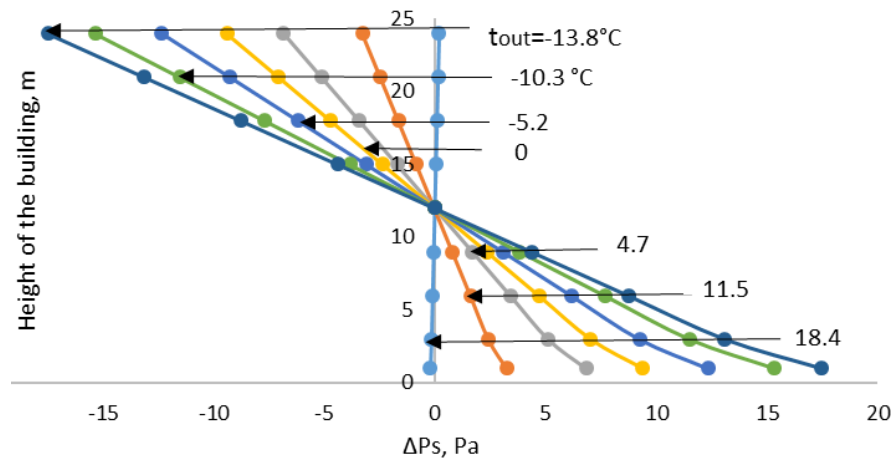

Figure 2. The change in pressure caused by the effect stack depending on the change in ambient air temperature.

Provided that the exterior air temperature is close to the interior one (peak solar activity during off-season) the pressure difference from the stack effect can be offset.

The study investigates changes in pressure difference height profile for different wind speed and direction at different ambient air temperatures and their effect on windward and leeward enclosures. Figure 3 presents the corresponding graphs of wind pressure profiles on the southern side of the building, depending on the building floor and wind direction. Representative days are used, for which the wind speed is 3 m/s (typical wind speed for the conditions of Ukraine [29]) and exterior air temperature is 3 °C (average typical exterior air temperature for December in the city of Kyiv (Ukraine) [28]). The graph shows that the magnitude of the pressure change caused by wind effect increases with height.

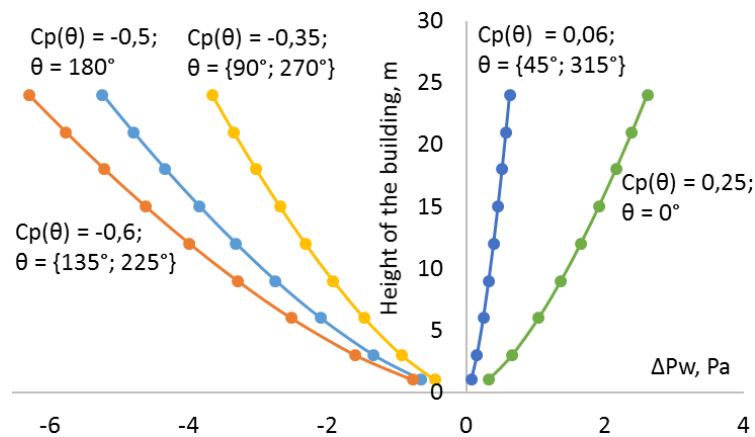

Figure 3. Changes in wind pressure depending on the incidence angle of the wind direction θ .

The wind vector directed to the surface (windward side) causes positive values of wind pressure difference, for leeward sides it is negative.

As mentioned above, northern and northwestern wind direction is typical for Kyiv (Ukraine). The average wind speed is 2.7 m/s, the wind speed greater than 8 m/s typically has northwestern direction. The change in wind pressure effect for different wind speed profiles and wind incidence angle $\theta = 0^\circ$ is shown in Fig. 4. Similar calculations are performed for incidence angles $\theta = 180^\circ$ (profiles are similar with a negative value of change in wind pressure). The analysis shows that the pressure difference increases with wind velocity increase.

Figs. 2-4 shows that the pressure difference caused by the stack effect has a greater effect on the natural the air exchange rate as opposed to the wind effect.

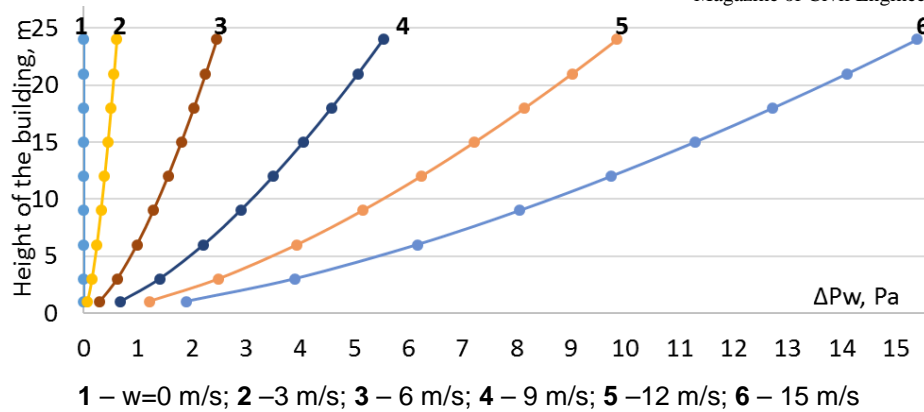

Figure 4. Change of wind pressure difference depending on change of wind speed at northern wind direction on the northern side of building ($\theta = 0^\circ$).

This paper investigates the natural component of air exchange, which is determined by the sum of the pressure difference from the stack and the wind effect. Fig. 5 shows the average resulting infiltration pressure difference depending on building height in January and March for the southern (S) and northern (N) orientations. Fig. 5 shows that for the first floors (1-3 floors) the typical effect is infiltration of the exterior air, where, accordingly, the heat consumption will be the highest. The profile of change in the average monthly values of infiltration pressure difference depending on the height in January is more low-angle that is stronger than in March for the similar premises. This feature is caused by a number of factors: the ambient air temperature decreases (the pressure difference from the effect stack increases); different wind speeds and directions specific for a particular period of the year.

Also, Figure 5 shows the profile of changes in the mean monthly values of the infiltration pressure difference depending on height for southern (S) and northern (N) orientations for March, the orientation difference is caused by wind effect (wind direction). A similar analysis was carried out for January data, the difference of profiles is less, which is caused by a combination of factors and their influence on the magnitude of the stack and wind effect of the pressure difference profiles.

Thus, the above method allows to determine the quantitative dependence of the distribution of infiltration pressure difference and air exchange on a specific set of characteristics of the terrain and building.

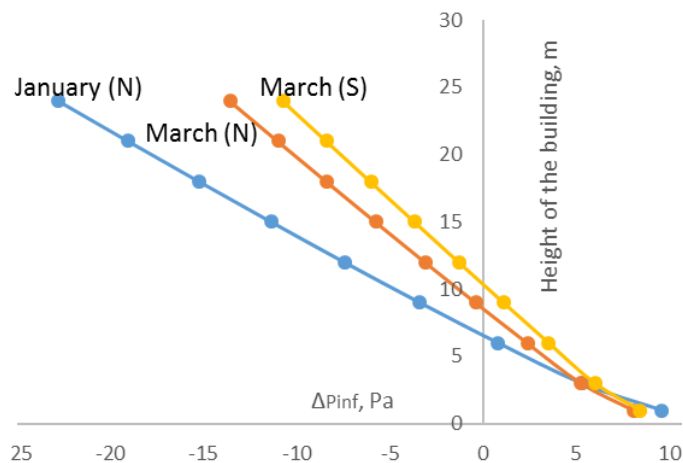
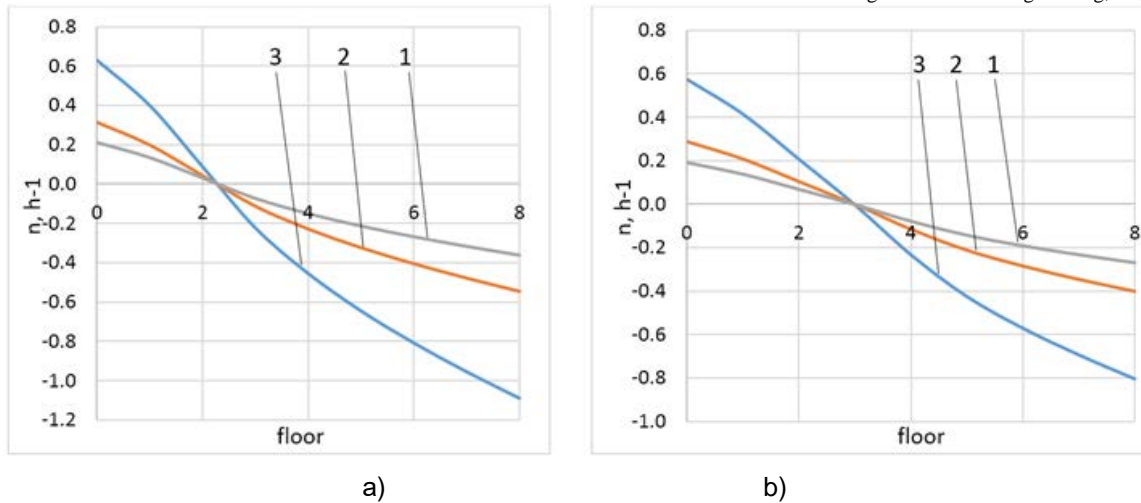

Figure 5. Change in average monthly pressure difference depending on height for January and March of typical year data for rooms with N and S orientation.

As mentioned above, the considered technique takes into account both infiltration and exfiltration natural air flows in the building. Fig. 6 shows an example of changing the air exchange rate for rooms of the northern (N) orientation of the building under consideration for different values of the air permeability coefficients. For the off-season, the air exchange rate decreases somewhat compared to the cold period, which is explained by the decrease in the temperature difference between the indoor and outdoor environment.



1 – for triple-glazed PVC windows; 2 – triple-glazed wooden windows; 3 – double-glazed wooden windows;

Figure 6. Average air exchange rate for representative premises (N orientation) for different types of window structures for January (a) and March (b).

An hourly calculation of air exchange rate was carried out for representative premises of different orientation and floor location. The natural air exchange rate for premises with north-eastern orientation is slightly smaller than for other orientations, which is related to the wind direction, the difference is more noticeable for windows with less air permeability resistance. The average annual calculated natural air exchange rate is about $0.25 h^{-1}$ – for triple-glazed PVC windows, $0.4 h^{-1}$ – triple-glazed wooden windows, $0.65 h^{-1}$ – double glazed wooden window. This value may actually be greater for older windows with wooden frames as airtightness has decreased during operation. During the year, the maximum value of the air exchange rate is greatest for double glazed windows and can range from -2 to $1.2 h^{-1}$, which is typical for periods with gusty winds of more than $15 m/s$.

During the off-season, the air exchange rate decreases somewhat compared to the cold period, which is explained by the decrease in the temperature difference between the indoor and outdoor environments.

On the ground floor there is a phenomenon of infiltration (fresh air inflow naturally due to leakage in window structures), in the above floors there is an area where it is on average close to zero, which is related to the NPL of the building (stack effect), on the upper floors there is an exfiltration which corresponds to negative air exchange rate values. Fig. 7 shows the variation of hourly values of air exchange rate during the season for premises on the ground floor with N orientation.

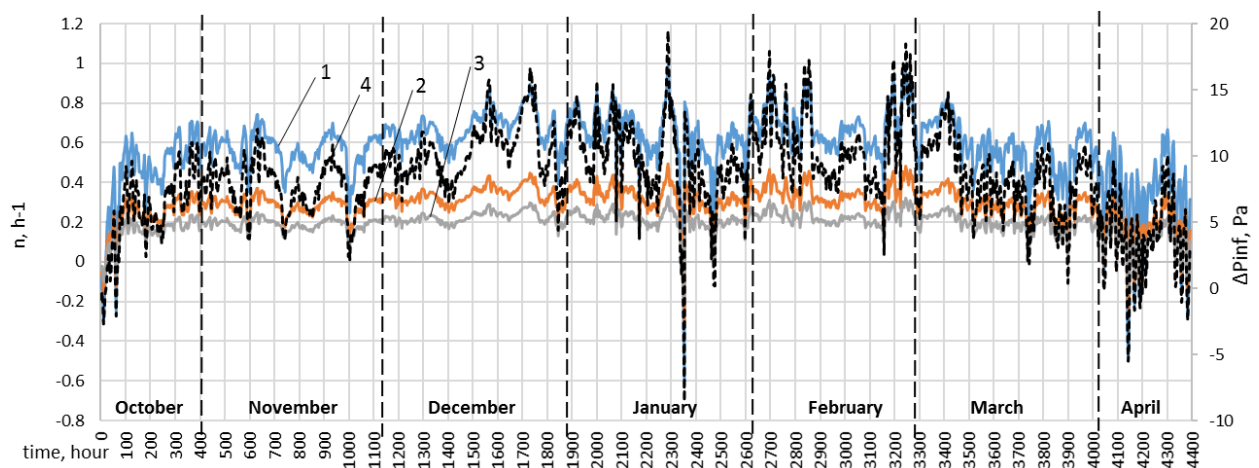

1 – double-glazed wooden windows; 2 – triple-glazed wooden windows; 3 – for triple-glazed PVC windows; 4 – pressure difference for natural ventilation

Figure 7. Hourly values of air exchange rate for premises on the ground floor with N orientation.

Fig. 7 shows that windows with improved thermophysical characteristics are less sensitive to fluctuations in environmental parameters. In general, on the ground floor the range of infiltration air exchange rate change is $-0.2 \dots 0.25 h^{-1}$ – for double-glazed windows with PVC profile, $-0.4 \dots 0.5 h^{-1}$ – for triple-glazed wooden windows, $-0.5 \dots 1 h^{-1}$ – for double glazed windows. The negative values of air

exchange rate on the ground floor are explained by a short gusty wind with a velocity of more than 10 m/s and a frontal direction to the considered enclosure.

The results of simulation of the average air exchange rate 0.25 h^{-1} was obtained for the heating season for triple-glazed windows with PVC profile. The similar results show that the annual average infiltration rates in Beijing range from 0.02 to 0.82 h^{-1} with a median value of 0.16 h^{-1} [15]. For upper floors (not shown in Fig. 6) the range of variation is $-1.5 \dots 0.25 \text{ h}^{-1}$ – for double-glazed windows with PVC profile, $-2 \dots 0.5 \text{ h}^{-1}$ – for triple-glazed wooden windows, $-4 \dots 1 \text{ h}^{-1}$ – for double glazed ones.

The obtained results show that for the ground floors there is a positive variation range of the hourly air exchange rate values, for the upper floors it is negative. For double-glazed windows, the air exchange rate of -4 h^{-1} is characterized by a wind speed of 18 m/s at the level of 10 m (meteorological measurements).

It should be noted that for the conditions of Ukraine this type of research was not conducted, similar trends are obtained for Chinese conditions [15], but quantitatively the differences in results are due to the different nature of buildings and climatic data.

The use of more efficient windows leads to less sensitivity depending of the air rate exchange on the considered factors, due to the fact that modern windows have greater air permeability resistance value. The obtained results show the dynamics of air exchange due to natural infiltration and how much it is necessary to supplement the air exchange mechanically to ensure comfort under certain modes / operating conditions [30].

3.2. Calculation of energy consumption and analysis of energy need for heating with change of actual natural air exchange rate

Input data. A group of representative rooms is in the buildings of typical development of the 1970s. Room dimensions are $5.5 \times 6.1 \text{ m}$, room height is 3 m. The room has one outside wall ($5.5 \times 3.0 \text{ m}$) with a window ($5 \times 2 \text{ m}$). The outer wall has a thermal resistance of $0.8 \text{ m}^2 \cdot \text{K/W}$ (the main layer is brickwork in one brick). Ceiling over the heated premises is reinforced concrete (20 cm). The building is located in Kyiv, Ukraine. The design indoor air temperature is 18°C . Solar heat gain coefficient for window is 0.56. Climate hourly data from the IWEK file for the city of Kyiv were used [27]. Solar heat gains are calculated using IWEK file data and EnergyPlus "Full interior and exterior with reflection" technique. The low level of thermal insulation properties is relevant for a large volume of buildings in countries such as Ukraine, Baltic States, Belarus, Hungary, Poland, Czech Republic, Slovakia, Russia.

Figure 7 shows the hourly variations of the outside temperature and solar heat gains for premises with N and S orientation during heating period.

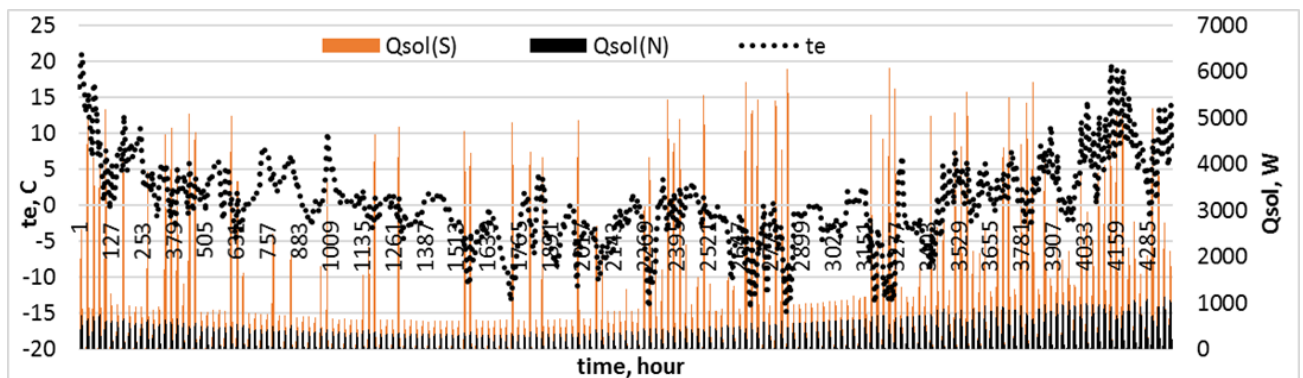

Figure 7. Variations of exterior air temperature t_{out} , solar heat gains Q_{sol} for premises with N and S orientation.

Model description. According to 5R1C model (dynamic grid room model, five resistances, one capacity), energy need for heating Φ_{HC} is calculated as the heating power value for each hour to be supplied to the indoor air temperature node (θ_{air}) to maintain a given temperature setpoint [6]. The dynamic method scheme is implemented on the basis of EN ISO 13790 [33] and EN ISO 13786 [34] and shown in Fig. 8.

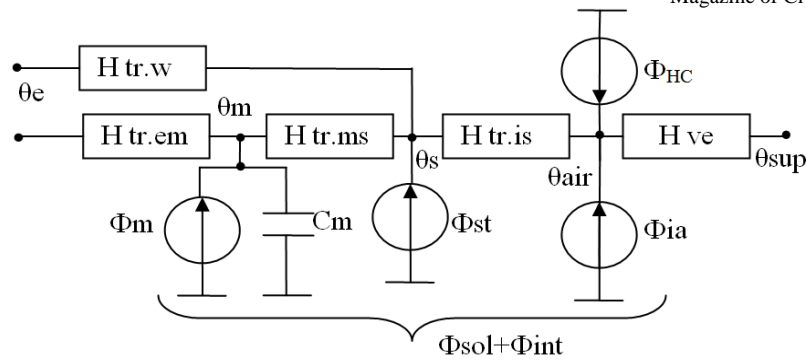

Figure 8 - Dynamic grid room model, five resistances, one capacity (5R1C) [2]: θ_{air} , θ_s , θ_e , θ_m , θ_{sup} are temperature of air, internal surfaces, external environment, opaque enclosures, supply air, respectively, °C; Φ_m , Φ_{st} , Φ_{ia} are additional solar (Φ_{sol}) and internal heat gains (Φ_{int}), distributed between the air node, the surface of the inner enclosure and walls, W; Φ_{HC} is heat flow from the heating system, W; C_m is internal heat capacity of opaque building enclosures, J/K; $H_{tr.w}$, $H_{tr.em}$, $H_{tr.ms}$, $H_{tr.is}$, H_{ve} are coupled conductivity between temperature nodes characterizing transmission losses through building envelope and ventilation, W/K.

The energy need for heating is based on the calculation of the heating level, $\Phi_{HC.nds}$, for each hour to be delivered to the internal air temperature node, θ_{air} , to maintain a certain set-point temperature. The set-point temperature is an average weighted value of internal air temperature and radiant temperature.

Heat transfer by ventilation, H_{ve} , is directly connected to internal air temperature node, θ_{air} , and the node that corresponds to supply air temperature, θ_{sup} . Heat transfer by transmission is divided into two parts: the first one is through fenestration surfaces, like windows, $H_{tr.w}$, that do not have thermal mass, the second one is through opaque surfaces H_{op} , that have thermal mass, and, in its turn, is divided into two parts: $H_{tr.em}$ and $H_{tr.ms}$. Solar (Φ_{sol}) and internal heat gains (Φ_{int}) are distributed between the internal air temperature node, θ_{air} , the central node, θ_s (mixture of θ_{air} and mean radiant temperature θ_r) and the node representing the building mass, θ_m . The thermal mass is reflected by the specific heat, C_m , located between $H_{tr.ms}$ and $H_{tr.em}$. The coupling by conductivity is determined between the internal air temperature and the central node. The value of the heat flux due to internal sources, Φ_{int} , and the value of the heat flux in the zone of the room due to the sun, Φ_{sol} , are divided between the three nodes: internal air temperature, θ_{air} , and internal nodes, θ_s , θ_m .

$$H_{tr.is} = h_{is} A_{tot} \quad (9)$$

$$H_{tr.ms} = h_{ms} A_m \quad (10)$$

$$H_{tr.em} = \frac{1}{\frac{1}{H_{op}} - \frac{1}{H_{tr.ms}}} \quad (11)$$

$$H_{tr.1} = \frac{1}{\frac{1}{H_{ve}} + \frac{1}{H_{tr.is}}} \quad (12)$$

$$H_{tr.2} = H_{tr.1} + H_{tr.w} \quad (13)$$

$$H_{tr.3} = \frac{1}{\frac{1}{H_{tr.2}} + \frac{1}{H_{tr.ms}}} \quad (14)$$

$$C_m = \sum k_j A_j \quad (15)$$

$$\Phi_{m.tot} = \Phi_m + H_{tr.em}\theta_e + \frac{H_{tr.3}(\Phi_{st} + H_{tr.w}\theta_e + H_{tr.1}(\frac{\Phi_{ia} + \Phi_{HC.nd}}{H_{ve}} + \theta_{sup}))}{H_{tr.2}} \quad (16)$$

$$\theta_m = \frac{\theta_{m,t} + \theta_{m,t-1}}{2} \quad (17)$$

$$\theta_{m,t} = \frac{\theta_{m,t-1}(\frac{C_m}{3600} - 0.5(H_{tr.3} + H_{tr.em})) + \Phi_{m.tot}}{\frac{C_m}{3600} + 0.5(H_{tr.3} + H_{tr.em})} \quad (18)$$

$$\theta_s = \frac{H_{tr.ms}\theta_m + \Phi_{st} + H_{tr.w}\theta_e + H_{tr.1}(\frac{\Phi_{ia} + \Phi_{HC.nd}}{H_{ve}} + \theta_{sup})}{H_{tr.ms} + H_{tr.w} + H_{tr.1}} \quad (19)$$

$$\theta_s = \frac{H_{tr.ms}\theta_m + \Phi_{st} + H_{tr.w}\theta_e + H_{tr.1}(\frac{\Phi_{ia} + \Phi_{HC.nd}}{H_{ve}} + \theta_{sup})}{H_{tr.ms} + H_{tr.w} + H_{tr.1}} \quad (20)$$

$$\theta_{air} = \frac{H_{tr.is}\theta_s + H_{ve}\theta_{sup} + \Phi_{ia} + \Phi_{HC.nd}}{H_{tr.is} + H_{ve}} \quad (21)$$

$\Phi_{ia}, \Phi_m, \Phi_{st}$ internal and solar radiation heat gains are distributed between the 3 nodes, $\theta_{air}, \theta_s, \theta_m$;

$\Phi_{m.tot}$ is total heat flow, W;

h_{is} is heat transfer coefficient between the internal air temperature node, θ_{air} , and central node, θ_s ,

has a fixed value $h_{is} = 3.45 \frac{W}{m^2 K}$;

h_{ms} is heat transfer coefficient between the nodes m and s, has a fixed value $h_{ms} = 9.1 \frac{W}{m^2 K}$;

A_m is effective mass area, m²;

A_j is area of the j-element, m²;

A_{tot} is the area of all external enclosures of the building, m²;

C_m is internal heat capacity, J/K;

k_j is internal heat capacity per unit area of the j-element of the building, J/(m²·K);

$H_{tr.is}$ is coupling by conductivity between node s and inside air temperature, W/K

$H_{tr.1}, H_{tr.2}, H_{tr.3}$ are conductivity of conditional nodes 1, 2, 3, W/K

Model validation. Based on the considered series of models and results of studies [35–37], a model built on the basis of the EnergyPlus software can serve as a reference model for verification. The verification of the simplified hourly calculation method of EN 13790 [23], implemented on the basis of the grid model 5R1C, was carried out with the model based on the EnergyPlus software product. The difference between the results of grid calculation models is less than 5 % and slightly higher value of load in 5R1C model is explained by the common node for internal and external envelope inertia protections, this feature can produce more model's discrepancy results in the summer. The models considered performed an hourly calculation. During the

heating period for the facility the located in Kyiv (Ukraine), the discrepancy between the results of the two models was estimated on the basis of an adjusted coefficient of determination of $R^2 = 0.968$.

Simulation results. When using the calculated values of the natural component of air exchange rate, due to infiltration (leaks in window construction), the supply of fresh air into the room area and heat loss significantly change under the influence of natural factors, and accordingly the energy consumption of the building also changes.

Mathematical modeling of specific energy need for heating of representative rooms of northern (N) and southern (S) orientation is carried out with the condition of only transmission losses ($n = 0$), for normative values of air exchange multiplicity ($n = 1 \text{ h}^{-1}$) and for the calculated value of natural component ($n = \text{var.}$) air exchange.

Fig. 9 shows the annual specific energy need for heating for northern (N) and southern (S) orientation on the example of representative rooms with triple-glazed energy-saving windows with PVC profile located on the ground floor. The maximum estimate of additional energy costs due to natural ventilation (infiltration) compared to energy consumption with only transmission losses ($n = 0$) differs by 23% for northern and 43 % for southern orientations.

The obtained value for the natural component of air exchange does not allow to provide a normative level of air exchange for comfortable working conditions. Comparison of the specific energy need for heating calculated for the normative values ($n = 1 \text{ h}^{-1}$) and the obtained level of natural air exchange establishes that the difference of energy need for the entire heating period can be more than 50 %, compared with $n = 1 \text{ h}^{-1}$. For example, for the premises on the ground floor with N orientation it can be 50 %, for S orientation it can be 65 %. This difference can be reduced by increasing air exchange rate during occupied hours, for example, by airing.

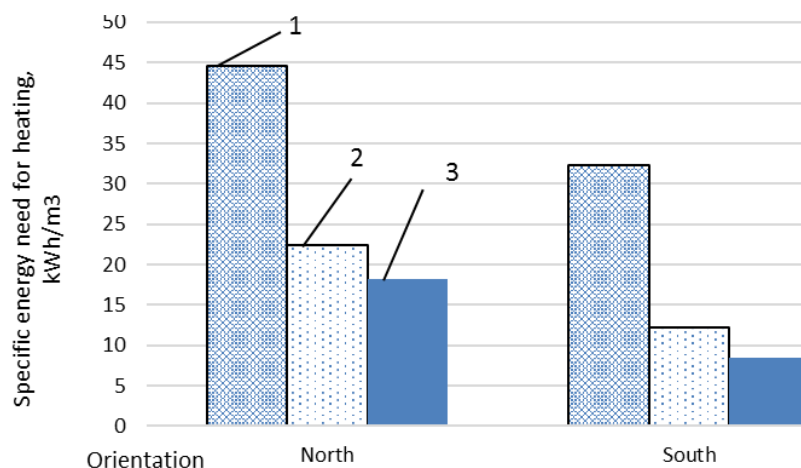

1 – normative values of air exchange rate $n = 1 \text{ h}^{-1}$; 2 – calculated (natural component) air exchange rate; 3 – no air exchange

Figure 9. Annual specific building energy need for heating under different conditions of air exchange

Fig. 10 shows the change in hourly values of specific energy for heating using normative (1) and calculated (2) values of natural air exchange rate and for premises with only transmission heat losses component (3) oriented to the North (a) and South (b) located on the ground floor.

The results of mathematical modeling show that at a certain level of natural air exchange for the considered type of windows (air permeability resistance), the heating system of the rooms oriented to the south can be switched off during the off-season (October, April), i.e. solar heat gains work as a passive heating system. The heating season can be reduced by more than 30 days.

During the cold period of the year, the energy need for heating calculated for the values of normative air exchange rate, and according to the variable natural conditions (natural exchange rate), line 2, varies up to 50 %, and for the off-season period the difference can be up to 75 %. Addition to the energy need due to natural air exchange (the difference between 2 and 3) is about 20 %, the value of fluctuations in the heating load increases by one and a half - two times.

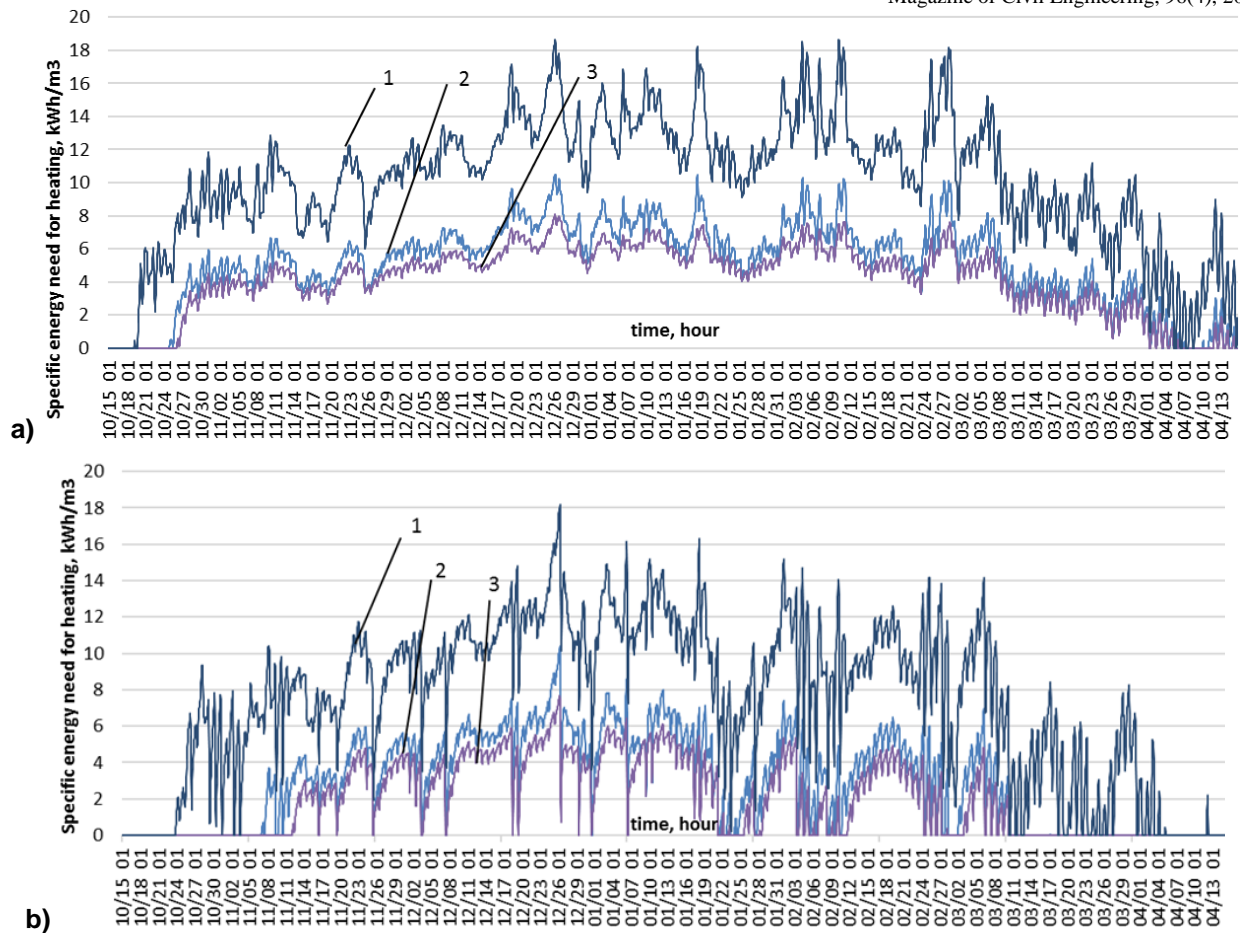

Figure 10. Load on the heating system for the heating period of the premises oriented to the north (a) and south (b): 1 – at the normative values of air exchange rate $n = 1 \text{ h}^{-1}$; 2 – calculated (natural component); 3 – no air exchange

For premises oriented to the South, the fluctuations of the load on the heating system during the day are somewhat larger and the effect of natural air exchange on them is not so obvious, unlike for the northern orientation, which is explained by solar heat gains into the premises. Also, on some days there are short-term shutdowns of heating during peak hours of solar activity, the amount of which is reduced by the influence of air exchange.

4. Conclusions

1. The article reviews literature sources and approaches to the assessment of natural air exchange in a building, taking into account the cumulative variability of a number of external and internal factors. A generalized technique for determining the natural air exchange rate for multi-story buildings is proposed, the considered methodology is based on ASHRAE approaches and allows to calculate natural air exchange for medium-sized buildings. The calculation was made for climatic conditions typical in Central and Eastern Europe. The calculations used the data of the international climate file IVEC (typical year), e.g. for the city of Kyiv, Ukraine. The natural component of the air exchange rate is calculated for air permeability coefficients of the most typical characteristics of window construction, namely: triple-glazed PVC window, triple and double-glazed wooden window. The calculation was carried out for representative premises of 8-story building that have one window of different orientation.

2. For energy efficient triple-glazed PVC windows an hourly calculation of the natural component of air exchange rate at different locations of representative premises showed that the infiltration value does not exceed 0.25 h^{-1} , for triple-glazed wooden windows it can be 0.4 h^{-1} , for double-glazed wooden windows it can be 0.65 h^{-1} . It should be noted that on the first floors, in general, the natural component of air exchange has a positive value (air infiltration), while on the last floors, it has a negative value (air exfiltration), which must be taken into account in the dynamic modeling of building energy performance.

3. General trends show that as thermal resistance of building envelope structures increases, heat losses are reduced, while the share of heat losses with air exchange increases ensuring conditions of comfort. In addition, the improvement of window structures leads to a decrease in natural air exchange through them. The research shows to what extent mechanical ventilation should be additionally used to maintain the normative value of the air exchange rate during the people occupancy period. In further studies it is planned

to perform hourly calculation of air exchange rate taking into account building air flow conditions with regard to the landscape, mechanical ventilation and heat recovery.

4. Dynamic grid models have been developed to study buildings energy performance based on EN ISO 13790 [33] and EN ISO 13786 [34] standards. The model was validated with the model created in the EnergyPlus software package.

It is established that the maximum estimate of additional energy costs due to natural ventilation (infiltration) compared to the energy consumption of the building with only transmission losses ($n = 0$) differs by 23 % for northern and 43% southern orientations for premises with energy efficient triple-glazed PVC windows. It is also established that the energy consumption of the building at the normative value of the air exchange rate ($n = 1 \text{ h}^{-1}$) and the calculated value of the natural component of the air exchange rate differs by 50–75 %, which is a possible savings result under the actual conditions of air exchange compared with the normative. This savings can be reduced by increasing air exchange during occupation periods using premises airing to ensure proper ventilation in the room.

5. For residential and public buildings of typical development of the post-Soviet countries there is a general tendency to improve the thermal characteristics of the building enclosures. Replacing windows reduces air exchange through natural ventilation, so more attention should be paid to mechanical ventilation. In order to maintain the normative value of the air exchange rate during occupancy, natural or mechanical ventilation should be used additionally. The actual natural component of air exchange in the premises of variable occupancy rate consideration specifies the determination of the level of energy-saving measures efficiency for thermo-modernization, a component that must be provided by mechanical ventilation, and can also be utilized in heat recovery devices. The dynamics of the air exchange rate influence on energy consumption under these conditions needs further investigation.

6. The results of the paper provide a methodology, demonstrate the needs and boundaries for quantifying natural air exchange for the conditions of Central and Eastern Europe (temperate climate) for typical characteristics of buildings in post-Soviet countries before and after window replacement.

5. Acknowledgements

The research was supported by Ministry of Education and Science of Ukraine under the project "Engineering aspects of energy management system functioning in residential and public facilities".

References

1. Deshko, V.I., Bilous, I.Yu. Mathematical Models for Determination of Specific Energy Need for Heating and Cooling of the Administrative Building. *International Journal of Engineering & Technology*. 2018. No. 4.3(7). Pp. 325. DOI:10.14419/ijet.v7i4.3.19826
2. Borodinecs, A., Zemitis, J., Sorokins, J., Baranova, D.V., Sovetnikov, D.O. Renovation need for apartment buildings in Latvia. *Magazine of Civil Engineering*. 2016. 68. Pp. 58–64. DOI:10.5862/MCE.68.6
3. Kostenko, V.A., Gafiyatullina, N.M., Semchuk, A.A., Kukolev, M.I. Geothermal heat pump in the passive house concept. *Magazine of Civil Engineering*. 2016. 68. Pp. 18–25. DOI:10.5862/MCE.68.2
4. Borodinecs, A., Prozuments, A., Zajacs, A., Zemitis, J. Retrofitting of fire stations in cold climate regions. *Magazine of Civil Engineering*. 2019. 90. Pp. 85–92. DOI:10.18720/MCE.90.8
5. Bayramukov, S.H., Dolaeva, Z.N. Dynamic programming in optimization of comprehensive housing stock modernization. *Magazine of Civil Engineering*. 2017. 76. Pp. 3–19. DOI:10.18720/MCE.76.1
6. Bilous, I.Y., Deshko, V.I., Sukhodub, I.O. Building inside air temperature parametric study. *Magazine of Civil Engineering*. 2016. 68. DOI:10.5862/MCE.68.7
7. Bilous, I., Deshko, V., Sukhodub, I. Parametric analysis of external and internal factors influence on building energy performance using non-linear multivariate regression models. *Journal of Building Engineering*. 2018. 20. DOI:10.1016/j.jobee.2018.07.021
8. Mukhtar, A., Yusoff, M.Z., Ng, K.C. The potential influence of building optimization and passive design strategies on natural ventilation systems in underground buildings: The state of the art. *Tunnelling and Underground Space Technology*. 2019. April(92). DOI:10.1016/j.tust.2019.103065
9. DSTU-N B V.3.2-3:2014. Nastanova z vikonannya termomodernizatsii zhitlovikh budinkiv. Chinniy vid 2015-10-01. K.: Minregion Ukraïni, 2015. 40 p.
10. Földváry, V., Bekö, G., Langer, S., Arrhenius, K., Petráš, D. Effect of energy renovation on indoor air quality in multifamily residential buildings in Slovakia. *Building and Environment*. 2017. 122. Pp. 363–372. DOI:10.1016/j.buildenv.2017.06.009
11. Younes, C., Shdid, C.A., Bitsuamlak, G. Air infiltration through building envelopes: A review. *Journal of Building Physics*. 2012. No. 3(35). Pp. 267–302. DOI:10.1177/1744259111423085
12. Jokisalo, J., Kalamees, T., Kurnitski, J., Eskola, L., Jokiranta, K., Vinha, J. A comparison of measured and simulated air pressure conditions of a detached house in a cold climate. *Journal of Building Physics*. 2008. No. 1(32). Pp. 67–89. DOI:10.1177/1744259108091901
13. Ren, Z., Chen, D. Simulation of air infiltration of Australian housing and its impact on energy consumption. *Energy Procedia*. 2015. 78. Pp. 2717–2723. DOI:10.1016/j.egypro.2015.11.611
14. Kalamees, T. Air tightness and air leakages of new lightweight single-family detached houses in Estonia. *Building and Environment*. 2007. No. 6(42). Pp. 2369–2377. DOI:10.1016/j.buildenv.2006.06.001
15. Shi, S., Chen, C., Zhao, B. Air infiltration rate distributions of residences in Beijing. *Building and Environment*. 2015. 92. Pp. 528–537. DOI:10.1016/j.buildenv.2015.05.027

16. Leivo, V., Prasauskas, T., Du, L., Turunen, M., Kiviste, M., Aaltonen, A., Martuzevicius, D., Haverinen-Shaughnessy, U. Indoor thermal environment, air exchange rates, and carbon dioxide concentrations before and after energy retro fits in Finnish and Lithuanian multi-family buildings. *Science of the Total Environment*. 2018. 621. Pp. 398–406. DOI:10.1016/j.scitotenv.2017.11.227
17. Stabile, L., Dell'Isola, M., Russi, A., Massimo, A., Buonanno, G. The effect of natural ventilation strategy on indoor air quality in schools. *Science of the Total Environment*. 2017. 595. Pp. 894–902. DOI:10.1016/j.scitotenv.2017.03.048
18. Salthammer, T. Formaldehyde sources, formaldehyde concentrations and air exchange rates in European housings. *Building and Environment*. 2019. 150. Pp. 219–232. DOI:10.1016/j.buildenv.2018.12.042
19. Ng, L., Persily, A. Airflow and indoor air quality analyses capabilities of energy simulation software. *Proceedings from Indoor Air 2011*. Austin, TX, United States; 5 June 2011 do 10 June 2011; Kod 97918
20. Ng, L.C., Persily, A.K., Emmerich, S.J. Improving infiltration modeling in commercial building energy models. *Energy and Buildings*. 2015. 88. Pp. 316–323. DOI:10.1016/j.enbuild.2014.11.078
21. Jokisalo, J., Kurnitski, J., Korpi, M., Kalamees, T., Vinha, J. Building leakage, infiltration, and energy performance analyses for Finnish detached houses. *Building and Environment*. 2009. No. 2(44). Pp. 377–387. DOI:10.1016/j.buildenv.2008.03.014
22. Chen, S., Levine, M.D., Li, H., Yowargana, P., Xie, L. Measured air tightness performance of residential buildings in North China and its influence on district space heating energy use. *Energy and Buildings*. 2012. 51. Pp. 157–164. DOI:10.1016/j.enbuild.2012.05.004
23. Nielsen, T.R., Drivsholm, C. Energy efficient demand controlled ventilation in single family houses. *Energy and Buildings*. 2010. No. 11(42). Pp. 1995–1998. DOI:10.1016/j.enbuild.2010.06.006
24. EnergyPlus Energy Simulation Software. <http://apps1.eere.energy.gov/buil-dings/energyplus>
25. Ng, L.C., Musser, A., Persily, A.K., Emmerich, S.J. Multizone airflow models for calculating infiltration rates in commercial reference buildings. *Energy and Buildings*. 2013. 58. Pp. 11–18. DOI:10.1016/j.enbuild.2012.11.035
26. Ng, L.C., Persily, A.K., Emmerich, S.J. Consideration of envelope airtightness in modelling commercial building energy consumption. *International Journal of Ventilation*. 2014. No. 4(12). Pp. 369–377. DOI:10.1080/14733315.2014.11684030
27. International Weather for Energy Calculations: https://energyplus.net/weather-location/europe_wmo_region_6/UKR.
28. DSTU B A.2.2-12:2015. Yenergetichna yefektivnist budivel. Metod rozrakhunku yenergospozhyvannya pri opalenni, okholodzhenni, ventilyatsii, osviltleni ta garyachomu vodopostachanni. Uvedeniy vpershe; chinniy vid 2015.01.01. K.: Minregionbud Ukraïni, 2015. 140 s.
29. DSTU-N B V.1.1-27:2010. Budivelna klimatologiya. K.: Minregion Ukraïni, 2011. 127 s.
30. Biler, A., Tavil, A., Su, Y., Kha, N. A Review of Performance Specifications and Studies of Trickle. *Vent. Buildings*. 2018. No. 8. Pp. 152–183. DOI:10.3390/buildings8110152
31. BERGE, A. Analysis of Methods to Calculate Air Infiltration for Use in Energy Calculations. Sweden 2011. Pp.98.
32. DSTU B V.2.2-19:2007 Metod viznachennya povitroproniknosti ogorodzhualnikh konstruksiy v naturnikh umovakh. – K.: Ukrarkhbudinform, 2008. – 20 s.
33. EN ISO 13790:2008. Energy performance of buildings – Calculation of energy use for space heating and cooling. – CEN. European Committee for Standardization, 2008. – 53 r.
34. EN ISO 13786:2007. Thermal performance of building component - Dynamic thermal characteristics - Calculation methods. — CEN. European Committee for Standardization, 2007 - 27 r.
35. Crawley, D.B., Lawrie, L.K., Winkelmann, F.C., Buhl, W.F., Huang, Y.J., Pedersen, C.O., Strand, R.K., Liesen, R.J., Fisher, D.E., Wittef, M.J., Glazer, J. EnergyPlus: Creating a new-generation building energy simulation program. *Energy and Buildings*. 2001. 33. Pp. 319–331. DOI: 10.1016/S0378-7788(00)00114-6
36. Krarti, M., Chuangchid, P., Ihm, P. Foundation heat transfer module for EnergyPlus program. Seventh International IBPSA Conference, Rio de Janeiro, Brazil August 13-15, 2001. P. 931–938.
37. Vivian, J., Zarrella, A., Emmi, G., Carli, M. An evaluation of the suitability of lumped-capacitance models in calculating energy needs and thermal behaviour of buildings. *Energy and Buildings*. 2017. 150. Pp. 447–465. DOI:10.1016/j.enbuild.2017.06.021

Contacts:

Inna Bilous, bilous_inna@ukr.net

Valerij Deshko, te@kpi.ua

Iryna Sukhodub, ira_krot@ukr.net

© Bilous, I.Yu., Deshko, V.I., Sukhodub, I.O. 2020