



DOI: 10.18720/MCE.100.4

The influence of reinforcing joints on the fire resistance of reinforced concrete structures

V.A. Rybakov^{*a}, O.V. Zhuvak^b, A. Hoffmann^c, F.A. Sergeeva^a, P.A. Verigo^a

^a Peter the Great St. Petersburg Polytechnic University, St. Petersburg, Russia

^b JSC Atomproekt, St. Petersburg, Russia

^c HALFEN GmbH, Langenfeld/Rheinld, Germany

* E-mail: fishermanoff@mail.ru

Keywords: Coupling joint, welded joint, rod reinforcement, fire resistance, fire protection, reinforced concrete

Abstract. This article analyzes the behavior of reinforcing joints when exposed to a fire load. The scientific work presents the results of an experiment on the fire resistance of reinforcing samples with coupling and welded joints. Experimental studies of cold and hot tensile samples were carried out. A test of loaded, heated and cooled rods was also performed, simulating the real effect of a fire on a loaded structure. During all three experiments, the values of the deformation and strength characteristics of the mechanical and welded joints of the bar reinforcement were compared. The experiment was verified in the Abaqus software package for the coupling connection in flexible reinforced concrete structures. Coefficients were derived that take into account the decrease in the strength of a reinforcing specimen with a sleeve connection depending on the heating temperature in the stressed state. Based on the data obtained using the studies, it can be concluded that the coupling and welded joints of the reinforcing bars give additional rigidity to the samples, without compromising the strength characteristics of the reinforcing bar. In the course of the experiments, the coupling and welded joints proved to be approximately the same, it should be noted that from the point of view of application efficiency, coupling joints have significant technological advantages compared to the welded joint.

1. Introduction

Currently, there is a need to use a large number of bent reinforced concrete structures that can withstand serious loads arising from the fire impact. The limit of fire resistance of the bent reinforced concrete structures on bearing capacity can come as a result of warming up of working armature to critical temperature that can lead to serious deformations of reinforced concrete and formations of plastic hinges. This occurs as a result of reducing the time resistance of rupture of the stretched reinforcement, which causes intensive crack opening in the concrete and accelerating the heating of the reinforcement.

Rebar is a key component of reinforced concrete and turns concrete into a durable and practical material. Therefore, it is necessary to monitor and observe the quality of work when creating a reinforcement cage. To create a strong "skeleton" of a reinforced concrete structure, it is necessary to use a strong reinforcement connection: coupling or welded. A welded joint is an all in one joint made by welding. A feature of the mechanical connection is the use of a reinforcing sleeve, which is a hollow metal cylinder with an internal parallel or conical thread corresponding to the external thread, which is cut or rolled at the ends of the connecting reinforcing rods. In addition to the use of these types of connections in civil construction, coupling and welded joints are used in the construction of largescale facilities, such as nuclear power plants, hydroelectric power plants, thermal power plants.

Currently, the behavior of reinforcement joints under fire is of scientific interest, because this issue has not been studied and not covered. No such studies are known to us. Prior to the experiments, the existing scientific research in the field of couplings and welds was studied. In the article [1] results of

Rybakov, V.A., Zhuvak, O.V., Hoffmann, A., Sergeeva, F.A., Verigo, P.A. The influence of reinforcing joints on the fire resistance of reinforced concrete structures. Magazine of Civil Engineering. 2020. 100(8). Article No. 10004. DOI: 10.18720/MCE.100.4



This work is licensed under a CC BY-NC 4.0

researches of reinforcing hire regarding weldability, endurance and relaxation of stresses according to requirements of the project of new Russian State Standard GOST 34028-2016 «hire reinforcing for reinforced concrete designs" are resulted». According to the results of the research and in the process of harmonization of the draft new Russian State Standard GOST, it is possible to note that the use of mechanical threaded connection valves allows to reduce construction time, reduce costs, and improve efficiency. The performed calculation of comparison of costs of reinforcing connections allows to be convinced that the mechanical threaded connection is cheaper for welding. In the article [2] Korenko and other authors the advantages of mechanical threaded connection of fittings in comparison with traditional lap joint and bath welding are considered. A comparable calculation of the cost comparison of reinforcement joints is performed. To assess the strength characteristics of the mechanical threaded connection was experimentally tested reinforcing rod class A500C diameter of 25 mm using coupling SS25A12 on the breaking machine. In article [3] group of authors carry out research of forecasting of quality of welded connections at contact butt welding by reflow on static characteristics. Authors presented the results of computational experiments to determine the effect of transverse dimensions of reinforcing bars of a sickle-shaped profile of class A500C on the stress-strain state of the anchor connection on acrylic adhesives [4]. Article [5] considers features of the complex scheme of formation of organizational and technological decisions on increase of efficiency of welding connections and their influence on threading of installation and realization of means of complex mechanization and automation of production processes and, as a consequence, on reliability of construction of objects of capital construction. In article [6] Klochanov I.E. options of connection of reinforcement of a periodic profile at reinforcement of building designs which provide continuity of formation of reinforcing frameworks are considered. The advantages and disadvantages of traditional methods of joining valves are determined and the technologies of threaded couplings, the nature of destruction during static strength tests for valves of class A500C are given. A variety of domestic reinforcing steels both by the methods of factory production and by the type of periodic profile, determines a special approach to the use of coupling connections on the thread. The direct dependence of the strength and deformation parameters of the threaded connection on the length of screwing and mechanical characteristics of the connected elements is shown. The author sets the task of creating a unified type of couplings when using for all widespread classes of valves of periodic profile. Dyachkov V.V. [7] dealt with the application of threaded and pressed mechanical joints of reinforcement in reinforced concrete structures.

Many domestic and foreign authors were engaged in fire resistance of bent reinforced concrete structures. In article [8] develop a mathematical model for calculating the temperature field of structural elements under various combined boundary conditions. As a criterion for the destruction of reinforced concrete structures, a critical temperature of 600°C at a depth of 2 mm from the heated surface at different heating speeds is proposed. Authors have resulted in the article typical graphic dependences of a limit of fire resistance on temperature of various materials and characteristics of fire resistance of building designs [9]. Zaitsev A.M. gave an analytical solution to the problem of non-stationary thermal conductivity to determine the heating of the enclosing structure under fire. He also gave the calculation methodology, specific examples of calculation and analysis of the results [10]. Belyavsky I.M. considered mathematical approaches to determining the ultimate fire resistance of building structures in accordance with the requirements of fire safety [11]. Authors gave a brief overview of Russian and international approaches to assessing the fire resistance of building structures [12]. Authors considered the development of regulatory requirements for fire resistance and basic design provisions [13]. Authors group described the study of nonlinear elemental analysis, which is able to predict the fire resistance of reinforced concrete slabs [14]. Li G.Q., Zhang N.S., Jiang J. in their article described the experimental studies of thermal and mechanical changes of floors under the action of fire [15]. Nazare S. and other authors in their study analyzed the factors that can affect the results of the flame impact test on the surface [16]. Authors group described tests in which more than 14 different samples of flame retardant coatings were affected by heat flows, in order to study the relationship between the thickness of the coating and the time of heat exposure [17]. Authors conducted a study in which they evaluated the effect of high temperatures and fire on concrete structures [18]. In article [19], the results of fire tests on suspended ceilings under standard fire temperature regime are presented in this study. Markus E. and others in [20] showed the application of the thermal pyrolysis model to predict flame spread over continuous and discrete fire load. The authors tested fire-resistant plaster coatings in work [21]. In article [22], the results of calculation of the quality control of holes for reinforced concrete structures are given by the example of fire-retardant coatings. The authors in their work [23] consider a special type of destruction of a heavy type of concrete under fire action, the so-called explosive spallation. The design of prestressed reinforced concrete slabs without the joint work of concrete and reinforcement is presented in article [24]. The author deals with the fire resistance assessment of compressed reinforced concrete elements in article [25].

Thus, the experimental base for studying the behavior of reinforcing joints in a fire is absent. The study of this issue should be continued, since reinforcing joints are involved in the formation of the frame of reinforced concrete structures, which significantly affects its strength.

In this paper a model of reinforced concrete floor considers, which is assembled on the armature joints, which is subjected to unilateral fire. It is assumed the formation of cracks in the stretched reinforced concrete curved structure at the joints of reinforcing bars under the influence of fire load (Fig. 1).

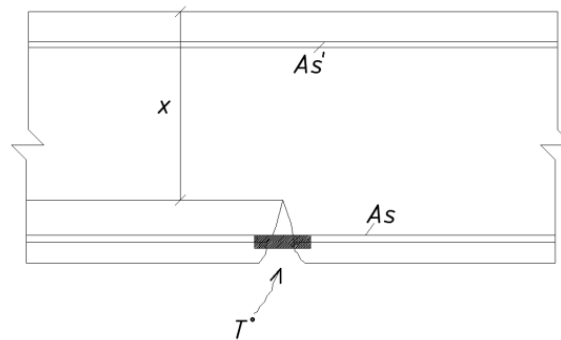

Figure 1. Fire damage of joints of connection of reinforcing bars.

Object of tests-coaxial coupling and welded joints of steel bar fittings and control steel bars of valves with $R_{s,n} = 500$ MPa $\varnothing 32$ mm.

The purpose of this work is to analyze the behavior of reinforcement joints under the influence of fire load. The following tasks follow from the set goal: definition and comparison of values of deformation and strength characteristics of mechanical and welded joints of steel bars fittings. It is necessary to establish experimentally the main parameters characterizing the strength characteristics of samples, such as:

- temporary resistance σ_b to rupture the stress corresponding to the highest load P_{max} , preceding the destruction of the sample.
- actual yield strength σ_t is the mechanical characteristic of a material that characterizes the stress at which strains continue to increase without increasing the load.
- deformability Δ is residual elongation of the sample after removal of the load $0.6 \sigma_t$.
- absolute elongation values δ at different loads and different times-a numerical value indicating how much the length of the sample has changed.

This article is an extended version of the report presented on the International Scientific Conference on Energy, Environmental and Construction Engineering (EECE 2019) [26].

2. Methods

The methodology of experimental studies is based on Russian State Standard GOST 34227-2017 "Mechanical reinforcement joints for reinforced concrete structures. The research model is the coupling joint of bar reinforcement. The dimensions of the samples are shown in Fig. 2.

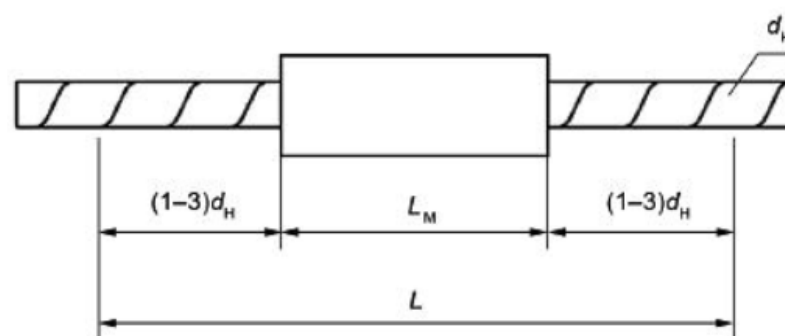

Figure 2. Determination of the length of the mechanical connection elongation measurement base.

L_M is coupling length = 72 mm;

D_H is nominal diameter of reinforcing bar = 32 mm;

L is gauge length for measuring elongation of a mechanical joint
 $=L_M+4D_H=72 \text{ mm}+128 \text{ mm}=200 \text{ mm}$.

Control steel bar is a piece of reinforcement with $R_{s,n} = 500 \text{ MPa } \varnothing 32 \text{ mm}$, cut from the same steel bar from which the samples are made connections.

Types of force loading:

1) a single static axial tension of the specimen up to $0.6 \sigma_t$ to obtain the deformability values (clauses 7.1.5-7.1.11 Russian State Standard GOST 34227-2014).

In order to measure the deformability of mechanical connections of reinforcing rods, the position of the measuring devices should correspond to Fig. 3:

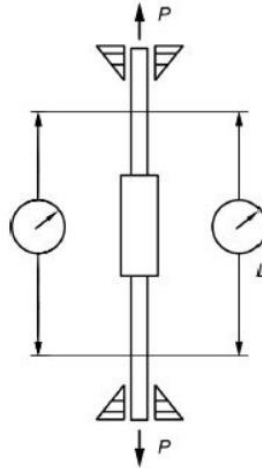

Figure 3. The scheme of installation of measuring devices at tests of samples of mechanical connections of reinforcing bars on tension.

2) axial tension of the specimen to obtain the actual tensile strength (before specimen rupture).

The specimen heating rate should correspond to the standard fire rate. Cooling to room temperature in natural mode. Monitoring the temperature change of samples with an accuracy of 5 % of the nominal value. During the test, the temperature change of the sample should not exceed 5 % of the nominal value.

If possible, it is necessary to minimize the effect of convective heating of the tensile testing machine and measuring instruments. The set temperature and constant tensile strength of the sample are simultaneously maintained during the initial stage of test No. 3.

Tensile tests of reinforcing bars and their joints were performed on the tensile testing machine R-100 of the Armavir plant with a maximum force of 100 000 kg_f (Fig. 4).



Figure 4. General view of the test machine R-100 Armavir plant and the number of the certificate of verification.

Temperature control was performed using a Raytek Raynger St (60) pyrometer with an accuracy of $0.5 \text{ }^\circ\text{C}$ (Fig. 5).



Figure 5. Thermometer Raytek Raynger ST (60).

During the experiment, digital and analog dial gauges were used to measure the deformability of reinforcement samples with an accuracy of 0.01 mm (Fig. 6).



Figure 6. The indicator of hour type ICH-10 and mechanical measuring sensors ICH-10 of hour type.

Three experiments were conducted.

2.1. "Cold" experiment No 1: tensile test to rupture of "cold" samples, at room temperature 20°C

At the beginning measuring instruments were installed on the sample, the measurement base was equal to $L_M + 4D_H = 72 \text{ mm} + 128 \text{ mm} = 200 \text{ mm}$; Next, the Sample was installed in the bursting machine (Fig. 7).



Figure 7. Installation of the sample in the measuring machine.

The Sample was stretched to $0.6 \sigma_t$, the values of absolute elongation δ_1 were determined. Every 5 tons readings were taken from the measuring sensors. Deformability Δ was measured. Next, the sensors were deduced at zero. The Sample was stretched to σ_t , thus determining the value of δ_2 . The readings were taken from the sensors.

In the end, measuring instruments were removed, the sample was loaded to its destruction, the force value corresponding to σ_b was determined. The value of the relative residual elongation was fixed.

2.2. " Hot "experiment No 2: tensile testing prior to rupture of" hot " samples preheated to 500°C

Further, some actions were performed. Measuring instruments were installed on the sample, the measurement base was equal to $L_M+4D_H=72\text{ mm}+128\text{ mm}=200\text{ mm}$. The Sample was installed in the bursting machine. With the help of a gas burner, the reinforcing joints were heated to a temperature of $\approx 500^\circ\text{C}$. The actual temperature of the sample was controlled by the instrument. Further, the sample was stretched to $0.6\sigma_t$, the value of absolute elongation δ_1 was determined. Every 5 tons readings were taken from sensors. The deformability was measured Δ . Next, the sensors were brought to zero. The Sample was stretched to σ_t , thus determining the value of δ_2 . Readings were taken from sensors. Measuring instruments were removed, the sample was loaded to its destruction, the force value corresponding to σ_b was determined. The value of the relative residual elongation was fixed.

2.3. Experiment No 3: Test of loaded, heated and cooled steel bars simulating the real impact of fire on the loaded structure

Further, some actions were performed. The Sample was installed in the breaking machine; the temperature was controlled corresponding to normal room conditions. Measuring instruments were installed on the sample, the measurement base was equal to $L_M+4D_H=72\text{ mm}+128\text{ mm}=200\text{ mm}$. The Sample was stretched to $0.6\sigma_t$, the value of absolute elongation δ_1 was determined. Was the measurement made deformability of Δ . Next, the sensors were brought to zero. The Sample was rest retched to $0.6\sigma_t$, the absolute elongation value δ_1 was re-determined. The reinforcement joints were heated to a temperature equal to 500°C under a load of $0.6\sigma_t$, the value of the absolute elongation δ_2 was determined, the readings from the sensors were recorded. Next, the sample cooled to room temperature, readings were taken from sensors to determine the elongation of δ_3 . The Sample was stretched to σ_t , thus determining the value of δ_4 . Readings were taken from sensors. Measuring instruments were removed, the sample was loaded to its destruction, the force value corresponding to σ_b was determined. The value of the relative residual elongation was fixed.

3. Results and Discussion

3.1. Experiment No 1. Cold samples

The values obtained as a result of the experiments are presented in Table 1 and Fig. 8.

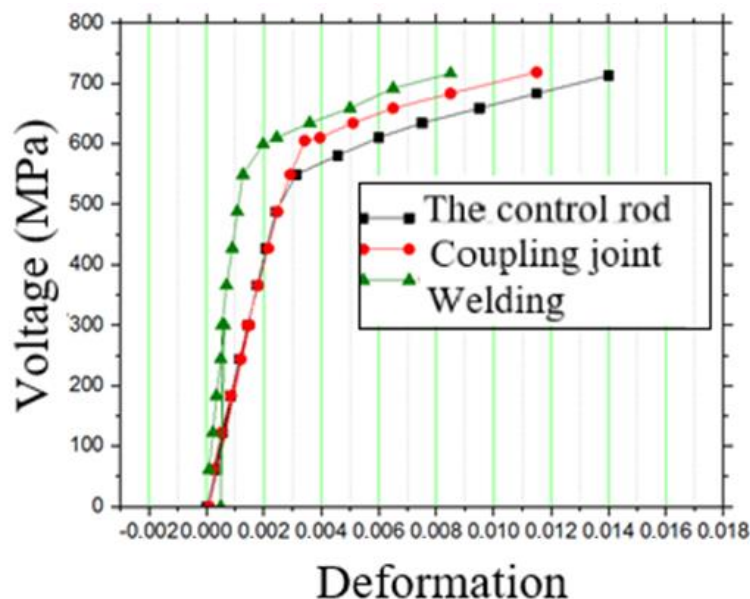

Figure 8. Stress-strain diagram in this experiment.

Final data obtained after the first experiment:

Table 1. The final results of experiment No 1. Testing of cold samples.

Test sample	Elongation sensor readings δ_2 at R_T , mm		Ab. elongation at R_T , mm	R_T Force, kgf	R_B Force, kgf	δ_p , %
One-piece steel bar	0.89	0.94	0.915	47600	58420	8
Socket joint	0.69	0.68	0.685	49600	58880	8
Welded joint	0.50	0.29	0.395	49100	58700	8.8

Thus, can see that the greatest value of the breaking force was achieved in the coupling connection, the smallest in the solid steel bar. In this experiment, none of the samples exploded within the compounds. The greatest values of deformations were obtained at the control steel bar.

3.2. Experiment No 2. Hot samples

The values obtained as a result of the experiments are presented in Table 2 and Fig. 9.

Table 2. The final results of experiment No 2. Testing of hot samples.

Test sample	Temperature, °C	R_T Force, kgf	R_B Force, kgf	δ_p , %
Socket joint	200	48800	55600	3.8
Welded joint	200	46600	54000	6.85

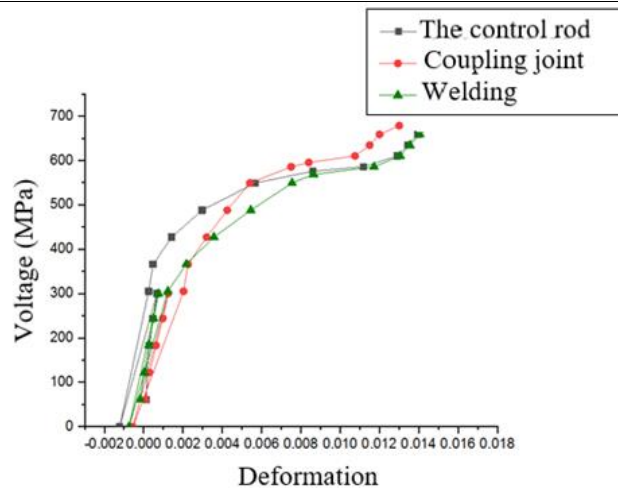
**Figure 9. "Stress-strain" diagram for hot experiment.**

In comparison with experiment No 1, the strength of the sample under temperature influence in the control steel bar decreased by 3 %, in the steel bar with the coupling by 5.5 %, in the welded joint by 8 %.

3.3. Experiment No 3. Testing of heated and cooled samples under load

The results of experiment 3 are presented in Table 3, 4 and Fig.10.

Table 3. Results of experiment No 3.

Test sample	Elongation sensor readings δ_2 at R_T , mm		Ab. elongation at R_T , mm	R_T Force, kgf	R_B Force, kgf	δ_p , %
One-piece steel bar	3.44	2.17	$\delta_4 = 2.805$	48400	53400	3.1
Socket joint	1.25	0.73	$\delta_4 = 0.99$	48200	58200	3.5
Welded joint	0.84	0.7	$\delta_4 = 0.77$	46400	56000	4.65

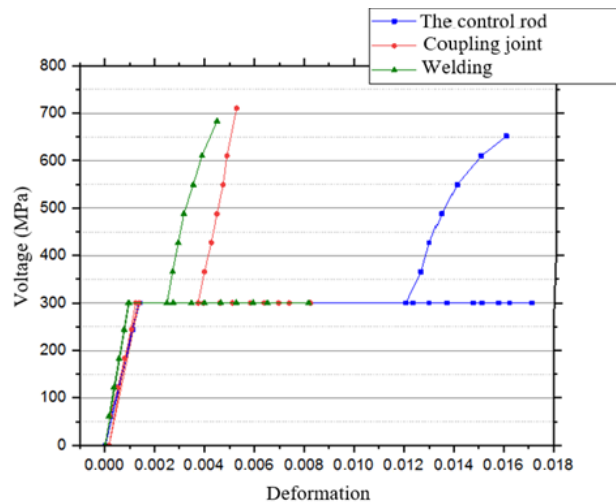

Fig. 10 Diagram of "stress-strain" experiment No 3

In comparison with experiment No 1, the strength of the sample after temperature exposure in the control strength decreased by 8.6 %, in the strength with the coupling by 1.16 %, in the welded joint by 4.6 %.

Table 4. Results of experiment No 3.

	Absolute elongations (mm) occurring in the sample at:		
	1) $t = \text{const}(20^\circ\text{C})$; $P \uparrow$ (0 to 24600 kgf), tensile force.	2) $t \uparrow$ (20°C to 500°C); $P = \text{const}$ (24600 kgf), t° stretching.	3) $t \downarrow$ (500°C to 20°C); $P = \text{const}$ (24600 kgf), t° compression.
Control strength	0.27	$3.42 - 0.27 = 3.15$	$3.42 - 2.415 = 1.005$
Socket joint	0.25	$1.65 - 0.25 = 1.4$	$1.65 - 0.75 = 0.9$
Welded joint	0.19	$1.635 - 0.19 = 1.445$	$1.635 - 0.5 = 1.135$
Residual temperature absolute elongation under constant tensile load after removal of temperature influence			
Control strength: 2.145 mm			
A sample with a t & C connection: 0.5 mm			
The specimen with a welded joint: 0.31 mm			

In experiment No 3, the temperature absolute value of residual elongation at the welded joint was between 0.31 mm, for socket was 0.5 mm, the difference between the absolute values of the temperature elongation of welded and coupling was 0.2 mm. However, the value of the temporary resistance is larger in a sample with socket connection. It is stronger than the sample with a welded joint by 2.2 tons. Also, we can conclude that the mechanical and welded joints of reinforcing bars give additional rigidity to the samples, which can be seen in the example of absolute elongation under the influence of tensile and temperature loads. The information obtained in the work allows us to reasonably expand the field of study of reinforcement joints to identify the best sample having high strength characteristics, and corresponding to the requirements of fire safety and fire resistance. The places of rupture of the samples after the third experiment can be seen in Fig. 11.



Figure 11. Places of rupture of samples after the 3rd experiment.

After the experiments, it was noted that no sample broke within the compound. All the breaks occurred outside of the compounds.

3.4. Discussion

Next, the results obtained compare with the results obtained by another calculation method - the finite element method. In article [26] a generic three-dimensional (3D) finite element (FE) based numerical model is presented for predicting thermo-mechanical behavior of load bearing reinforced concrete (RC) walls exposed to fire. This papers [27–28] presents a three-dimensional nonlinear finite element analysis for evaluating the fire response of reinforced concrete beams using ANSYS. In article [29] the numerical model utilizes a macroscopic finite element based approach to trace thermo-mechanical response of FRP-strengthened RC slabs from linear elastic stage to collapse under fire conditions.

Program complex "Simulia ABAQUS CAE 2017" will be used as a verification software package. In article [30], a finite element based numerical model is developed in ABAQUS for tracing the response of reinforced concrete beams exposed to fire. The authors in article [31] performed modeling and numerical analysis of the interaction of concrete and reinforcement using volumetric finite elements taking into account the nonlinearity of the work of materials.

Based on the experiments and the data obtained, a second experiment was conducted in the program complex "Abaqus". The properties of the material, depending on temperature, were set, such as: density, elastic modulus, coefficient Poisson, thermal conductivity, linear expansion coefficient, specific heat. The coefficients were derived, taking into account the de-crease in the strength of the reinforcing sample with a coupling connection depending on the heating temperature in the stressed state (Table 8). This coefficient is found by the formula 1:

$$\gamma_A = \frac{\sigma_b}{(\sigma_{b,actual})} \quad (1)$$

where, $\sigma_{v, fact} = 7.18 \cdot 10^8$ Pa. The value of the time resistance of the sample is obtained from an earlier experiment at 20 °C for the coupling.

The stress distribution in the finite element model of the sample with a sleeve connection is shown in Fig. 12, the temperature distribution in Fig. 5, the fracture zone in Fig. 14.

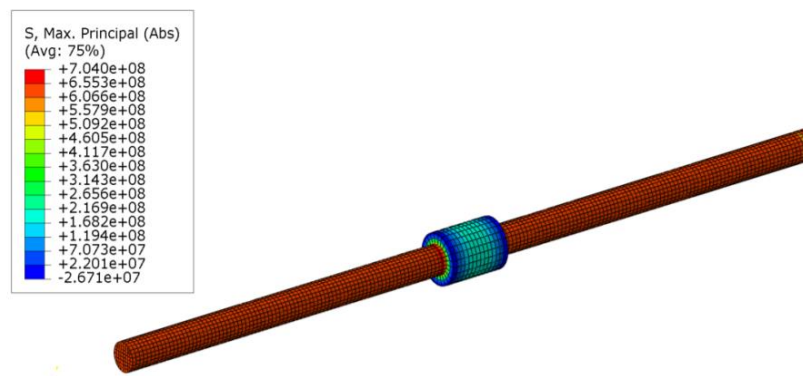

Figure 12. Stress at 200°C in a finite element model of a coupling specimen.

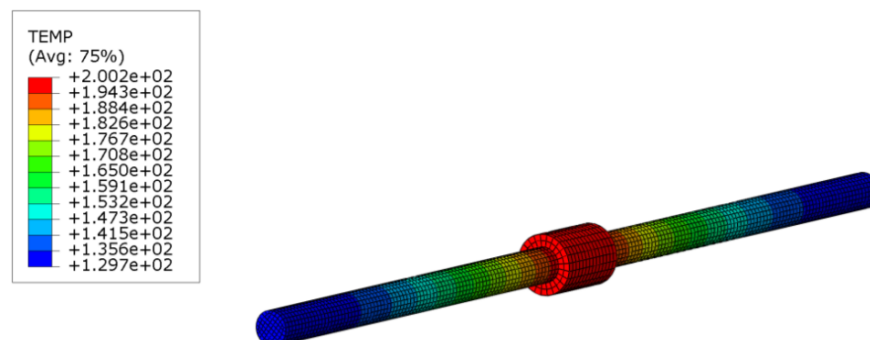

Figure 13. The temperature applied to the sample.



Figure 14. Fracture zone at 200°C.

Table 5. Coefficient γ_A at different temperatures.

Temperature	20°C	100°C	200°C	300°C	400°C	500°C
Temporary resistance in a heated sample	$7.15 \cdot 10^8$	$7.10 \cdot 10^8$	$7.04 \cdot 10^8$	$6.8 \cdot 10^8$	$6.3 \cdot 10^8$	$5.8 \cdot 10^8$
σ_B (MPa)						
γ_A	0.995	0.988	0.979	0.946	0.876	0.807

4. Conclusion

On the basis of the data obtained with the help of the conducted studies, it is possible to draw conclusions:

1. Coupling and welded joints do not degrade the strength characteristics of the reinforcing steel bar and reinforcement structures in General.
2. Coupling and welded joints of reinforcing bars give additional rigidity to the samples. This is noticeable in terms of absolute elongation.
3. According to the results of hot experiment № 2, the strength of the sample in the control steel bar decreased by 3 %, in the steel bar with the coupling by 5.5 %, in the welded joint by 8 %. According to the results of experiment № 3, the strength of the sample after temperature exposure in the control steel bar decreased by 8.6 %, in the steel bar with the coupling by 1.16 %, in the welded joint by 4.6 %. It is necessary to expand the field of study of reinforcement joints to identify the sample having the best strength characteristics.
4. The temperature lowers the strength characteristics of the structure, in addition, there is an increase in the value of deformability due to thermal action (thermodeformativity).
5. Since in General, during the experiments, the coupling and welded joints have shown themselves to be approximately the same, it should be noted that from the point of view of the effectiveness of the coupling joints have significant technological advantages compared to the welded joint.

5. Acknowledgments

We express our gratitude:

1. The research is funded by the Ministry of Science and Higher Education of the Russian Federation as part of World-class Research Center program: Advanced Digital Technologies (contract No. 075-15-2020-934 dated 17.11.2020).
2. Ancon for providing materials and preliminary information that was useful in the conduct of this study.
3. To employees of separate division of LLC FPG "ROSSTRO" – "PKTI", in particular, to Belov Ivan Pavlovich, for the help in carrying out research.

References

1. Tsyba, O.O., Dyachkov, V.V., Savrasov, I.P., Panchenko, A.I. On the new interstate standard GOST 34028-2016 "reinforcing bars for reinforced concrete structures". Bull. BSTU. V. G. Shukhov. 2017. (3). Pp. 23–31.
2. Korenko, S.S., Komarov, D.A., Rudenko, A.A. To an estimation and efficiency of mechanical connection of metal armature. Science and education. 2017. 6. Pp. 1–8.

3. Chvertko, E.P., Shevchenko, N.V., Pirumov, A.E. Forecasting the quality of welded joints in contact butt welding by reflow according to statistical characteristics. Bulletin of the Donbass state machine-building Academy. 2012. 3(28). Pp. 274–279.
4. Babaev, V.N., Shishkin, E.A., Sklyarov, V.A., Garbuz, A.O. Influence of transverse dimensions of reinforcing bars of sickle-shaped profile with R_s , $n = 500$ MPa on the stress-strain state of the anchor connection. Komunalne gospodarstvo mist. Naukovotekhnichny zbirnik. 2012. 107. Pp. 27–32.
5. Torkatyuk, V.I., Denisenko, A.P. Formation of parameters of organizational and technological decisions on increase of efficiency of welding connections. Municipal economy of cities. Scientific and technical. 2015. 77. Pp. 192–205.
6. Klochanov, I.E. Influence of mechanical properties of materials of couplings of armature. Modern problems of Science and Education. 2014. 2. Pp. 1–6.
7. Dyachkov, V.V. Properties and features of application in reinforced concrete structures of threaded and pressed mechanical joints of reinforcement. The dissertation for the degree of candidate of technical sciences. 2009.
8. Enaleev, R.Sh. Sh. et al. Fire resistance of elements of building structures at high-intensity heating. Pozharovzryvobezopasnost. 2010. 19(5). Pp. 48–53.
9. Trukhina, A.M., Ismagilova, E.P., Agashkov, E.M., Gavrishchuk, V.I. Review of modern ways to increase fire resistance of building structures. Key safety issues in the development of natural-industrial systems. 2016. Pp. 70–78.
10. Zaitsev, A.M. Calculation of fire resistance of building envelopes in different conditions of heat transfer on the opposite surfaces. Bulletin of the Voronezh Institute of the State Fire Service of the Ministry of Emergencies of Russia. 2017. 23(2). Pp. 46–58.
11. Belyavsky, I.M. Determination of fire resistance of building structures according to safety requirements. Actual problems and prospects of development of economy, management and education. 2016. Pp. 26–30.
12. Eremina, T.Y., Minailov, D.A. Improving the regulatory framework in the field of fire resistance of building materials. Fire and emergency. 2014. (3). Pp. 32–36.
13. Krivtsov, Y.V., Pronin, D.G. Fire Resistance of buildings and structures: regulatory requirements and design justification. Herald SIC construction. 2014. (11). Pp. 55–66.
14. Dr. Ayad A. Abdul-Razzak. Geometric and material nonlinear analysis of reinforced concrete slabs at fire environment. Tikrit Journal of Engineering Science. 2013. 15(6). Pp. 1–16. DOI: <https://doi.org/10.1007/s10409-011-0520-2>
15. Guo-Qiang, L., Nasi Zhang, J.J. Experimental investigation on thermal and mechanical behavior of composite floors exposed to standard fire. Fire Safety Journal. 2017. (89). Pp. 63–76.
16. Nazaré, S., Pitts, W.M., Shields, J., Davis, R. Factors for consideration in an Open-Flame test for assessing fire blocking performance of barrier fabrics. Polymers. 2016. Pp. 342.
17. Grigonis, M., Mačiulaitis, R., Lipinskas, D. Fire Resistance Tests of Various Fire Protective Coatings. Medziagotyra. 2011. Pp. 93–98.
18. Morales, G., Campos, A., Faganello, A. The action of the fire on the components of the concrete. Seminar: Ciências Exatas e Tecnológicas. 2011. (32). Pp. 47–55. DOI: <https://doi.org/10.5433/1679-0375.2011v32n1p47>
19. Gravit, M.V., Golub, E.V., Grigoriev, D.M., Ivanov, I.O. Fireproof suspended ceilings with high fire resistance limits. Magazine of Civil Engineering. 2018. 84(8). Pp. 75–85. DOI: 10.18720/MCE.84.8
20. Markus, E., Snegirev, A., Kuznetsov, E., Tanklevskiy, L. Application of the thermal pyrolysis model to predict flame spread over continuous and discrete fire load. Fire Safety Journal. 2019. 108(January). Pp. 102825. DOI: 10.1016/j.firesaf.2019.102825
21. Gravit, M.V., Golub, E.V., Antonov, S.P. Fire protective dry plaster composition for structures in hydrocarbon fire. Magazine of Civil Engineering. 2018. 79(3). Pp. 86–94.
22. Gravit, M.V., Dmitriev, I., Ishkov, A. Quality control of fire retardant coatings for reinforced concrete structures. IOP Conference Series: Earth and Environmental Science. 2017. 90(1). Pp. 4.
23. Gravit, M.V., Golub, E. Improving the fire resistance of reinforced concrete structures with polypropylene microfiber. MATEC Web Conference. 2018. 245. Pp. 7.
24. Plevoda, I.I., Zainudinova, N.V., Chaychits, N.I. The results of the fire test of reinforced concrete prestressed slabs without adhesion of reinforcement to concrete. University of Civil Protection of the Ministry of Emergencies of the Republic of Belarus. 2016. 23(1). Pp. 37–44.
25. Ilyin, N.A. Determination of fire resistance of compressed reinforced concrete structures of buildings. Bulletin of the SSACU. Urban Planning and Architecture. 2015. 18(1). Pp. 82–89.
26. Rybakov, V., Zhuvak, O., Verigo, R., Sergeeva, F., Verkhushkin, D., Riabov, A., Hoffmann, A. Thermomechanical Characteristics of Coupling and Welded Joints in Reinforced Concrete Structures. Proceedings of EECE 2019. Lecture Notes in Civil Engineering. 2020. Pp. 613–624. doi.org/10.1007/978-3-030-42351-3

Contacts:

Vladimir Rybakov, fishermanoff@mail.ru

Oksana Zhuvak, zhuwak2010@mail.ru

Andre Hoffmann, andre.hoffmann@halfen.ru

Faina Sergeeva, faasergeeva811@gmail.com

Polina Verigo, melomanka50@icloud.com