



DOI: 10.18720/MCE.100.12

## Mechanical properties of sustainable wooden structures reinforced with Basalt Fiber Reinforced Polymer

K.G. Kozinets<sup>a</sup>, T. Kärki<sup>b</sup>, Yu.G. Barabanshchikov<sup>a</sup>, V. Lahtela<sup>b</sup>, D.K. Zotov<sup>\*a</sup>

<sup>a</sup> Peter the Great St. Petersburg Polytechnic University, St. Petersburg, Russia,

<sup>b</sup> Lappeenranta University of Technology, Lappeenranta, Finland,

\*E-mail: zotovdk@gmail.com

**Keywords:** timber, basalt fiber, sustainable materials, FEM, wooden structures

**Abstract.** The long-lasting materials are sustainable goal for future, which were improved with various material combination, such as wood and basalt fibers. When materials with various nature were combined, properties might be altered and those must be evaluated. This study investigates the effect of basalt fibers on the wooden structure. Test materials were three various wood frames; pure, reinforced, and basalt fiber reinforced frames. The materials were analyzed by mechanical tests and elements were modelled with software package. In mechanical test, the strength value of pure and reinforced wooden structures ranging from 5.2 to 11.2 kN with a 19–25 mm deformation. The strength and deformation of basalt reinforced frames varied between 12.0–18.6 kN and 4–6 mm, correspondingly. Finite element modeling supported to the achieved results in the mechanical tests. It is concluded that basalt fiber reinforced wooden structures are more sustainable material from the viewpoint of material features.

### 1. Introduction

Sustainable practices in materials science have received increasing attention last time, such as light-weight, reduced emission and waste amounts, as well as improved material properties. The circular economy is a model that contributing the principle of sustainability. One strategy of circular economy is to extend what is made [1]. Therefore, it is essential to improve material, which life cycle is so long-lasting as possible, such as wooden structures. Wood is a popular material in construction and the market share of wooden multistory apartments were grown remarkable in the Nordic countries during last decade [2]. The wooden structures are environmentally less impactful compared to the concrete structures [3], but it still must be remembered that wood in products should have a design life span that matches timber rotation periods that might be 35 years and more [4]. Therefore, the improvement of material properties must be studied with care, such as advanced mechanical properties.

Currently, a large number of lightly loaded structures are being constructed from metal, for example, summer houses, pavilions, short pedestrian bridges [5]. The loads acting on these structures are noticeably lower than critical for metal, which has a significant for these structures own weight. For such structures, metal can be replaced by wooden structures [6]. Wood is barely light, tensile and ecologic material. But now days, it is not very distributed due its poor strength characteristics in comparison with steel and concrete as civil engineering material. By reinforcement, it can be made tougher [7]. For example, one way is to reinforce it by using basalt fiber reinforced polymer [8], like the way wood is repaired using epoxy [9]. Basalt fiber is a sustainable alternative for reinforcement, due to unlimited reserves and simple manufacturing process, for instance [10]. One approach is to reinforce by combining wood and basalt fiber reinforced polymer. To obtain a strong contact, the reinforcement of basalt fiber is made directly on wood [11]–[14]. At the same time, wood receives new properties, such as increased tensile strength [15]. Another approach, is to use basalt fabric reinforcement [16]–[19]. It can be used as lamination material on wood, or other construction material. At the same time, mass, volume and geometric characteristics remain unchanged. Assessing these changes is difficult due to the orthotropy of wood and the isotropy of basalt fiber reinforced polymer [29–32]. One of the most relevant methods is mechanical strength testing. But due

Kozinets, K.G., Kaarki, T., Barabanshchikov, Yu.G., Lahtela, V., Zotov, D.K. Mechanical properties of sustainable wooden structures reinforced with Basalt Fiber Reinforced Polymer. Magazine of Civil Engineering. 2020. 100(8). Article No. 10012. DOI: 10.18720/MCE.100.12



This work is licensed under a CC BY-NC 4.0

to the limited size of the test benches, it is possible to test only small parts. For testing finished products and taking into account the maximum number of influencing factors, in any case, the use of finite element modeling [20]–[25] ensure with strong results validation.

## OBJECTIVES

In this study we assessed the maximum possible designs to obtain the relevant results. The objective of this study was to demonstrate that the functionality of wooden structures that can be improved with the presence of basalt fiber. The functionality of wooden structures was evaluated by mechanical strength test and modelling of element with software package. This study offers a contribution to the available knowledge of basalt fibers' effects, and an initial basis for further research.

## 2. Materials and Methods

### 2.1. Sources of materials and mechanical properties

Three various wooden frames were tested with the following parameters; T1, T2, T3 are pure wood frames, T1A, T3A – are reinforced T1 and T3 frames, and T1L7, T2L4, T3L3 are different type of frames – they are reinforced with basalt fiber lamination. The wood used is coniferous, in this case, first class pine, with a minimum number of knots, exclusively in the center of the canvas. They are shown on Fig. 1.

Pine wood has density from 487 to 520 kg/m<sup>3</sup>. Pine belongs to the genus of conifers. A total of about one hundred and thirty species of pine are known. Pine is an evergreen tree containing a large amount of resin. The most common species in Russia is ordinary pine. Pine is the most used type of wood in Russia. About 30% of all types of wood used in Russia is pine. Pine wood is not afraid of the effects of fungi, insect pests, putrefactive damage due to increased resinity. According to this indicator, pine varieties are divided into the first type (with a high resin content) and the second type (reduced resin content). Resin pine is not recommended for use in carpentry, since the resin makes it difficult to saw and plan, sticking to tools. When heated, the varnish coating may rise. High resin content pine wood must be treated before processing. For this, solvents, acetone, gasoline, alkali solutions, and alcohol substances are used. Also, pine lumber is divided into grades by the presence of defects (in particular, knots). For class 1 lumber, up to 40 mm thick, no more than 3 knots per linear meter are allowed, no more than 1/4 of the size of the lumber.

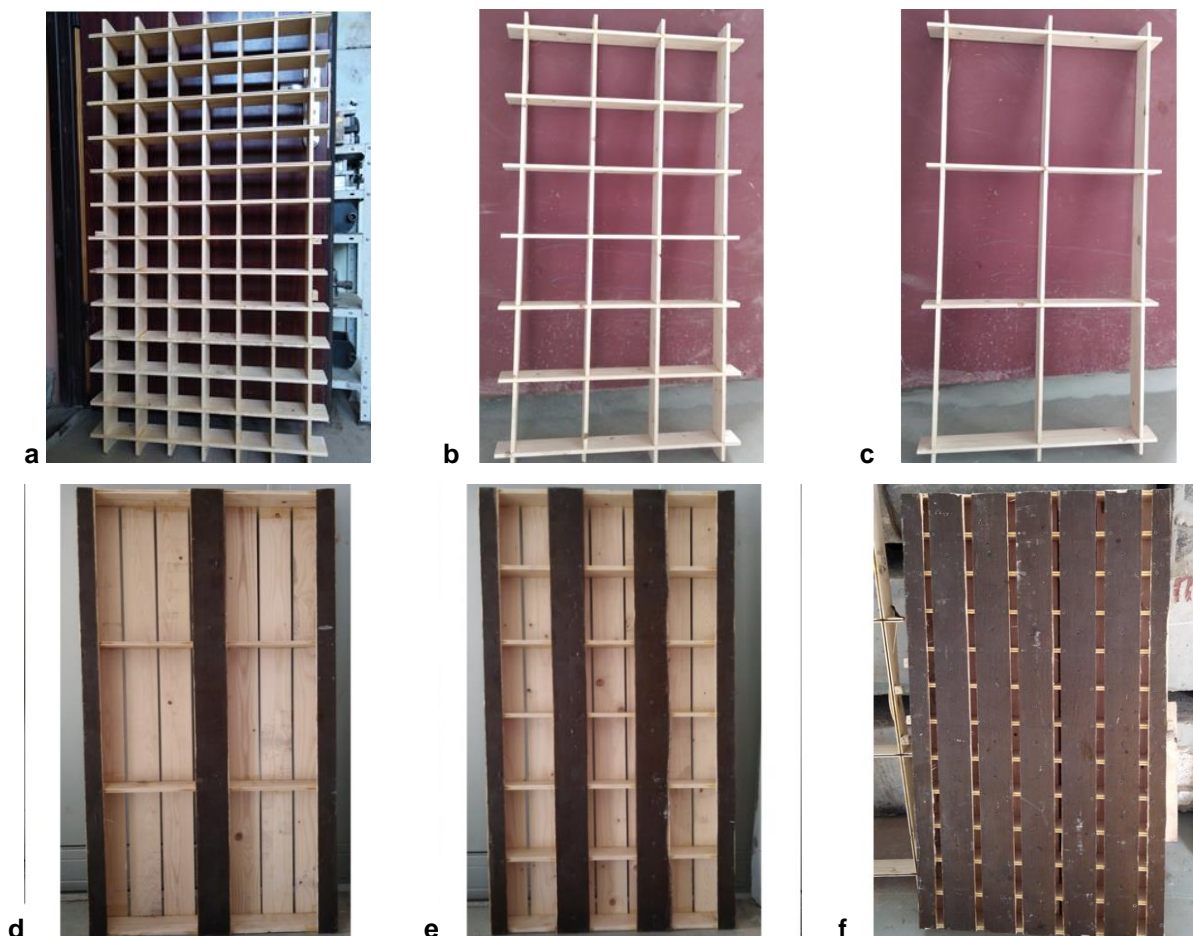

**Figure 1. Frame types. (a) T1, T1A; (b) T2; (c) T3, T3A; (d) T1L7; (e) T2L4; (f) T3L3.**

The reinforcement material for frames T1, T2, T3, T1A, T3A is basalt-fiber rowing reinforced with epoxy-diane resin (Epoxy ED-20).

## 2.2. Mix design

Density of ED-20 is  $1166 \text{ kg/m}^3$  in uncured state. Dynamic viscosity,  $13\text{--}20 \text{ Pa} \cdot \text{sec}$ , at  $(25 \pm 0.1) \text{ }^\circ\text{C}$ . It consists of epoxy groups (20.0–22.5%), chlorine ion (0.001 %), saponified chlorine (0.3 %), hydroxyl groups (1.7 %). Of the distinguishing features of the ED-20, excellent adhesion to wood and does not cause corrosion of materials in contact with them. As a hardener was used Polyethylenepolyamine. Its density is  $0.956\text{--}1.011 \text{ g/cm}^3$ . Bulk prp mixing with epoxy is 10%.

Basalt roving with a fiber thickness of 10 microns and a linear density of  $4800 \text{ mg/m}$ , Specific density  $2.67 \text{ g/cm}^3$ . Breaking load is  $500\text{--}650 \text{ mN/Tex}$ .

The result of reinforcement is shown in Fig. 2. And the reinforcement material for frames T1L7, T2L4, T3L3 is reinforced with basalt fabric, by lamination. The result of reinforcement is shown in Fig. 2. Blueprints of both types of reinforcements are shown on Fig. 3.

As basalt fabric, was used Basalt fabric TBK-100. The width of the original canvas  $1000 \text{ mm}$ . The surface density of  $190\text{--}230 \text{ g/m}^2$ . Number of threads  $9\text{--}11 / \text{cm}$ . Breaking load of  $780 \text{ N}$ . Thickness  $0.19 \text{ mm}$ .

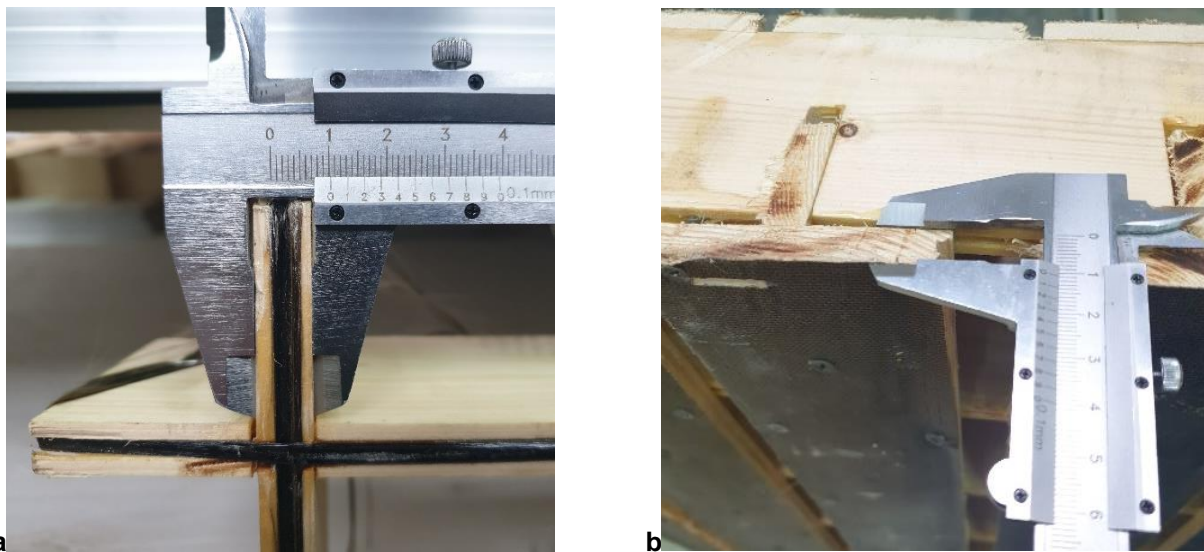

Figure 2. The result of basalt fiber reinforcement (a) and the result of basalt fabric reinforcement (b).

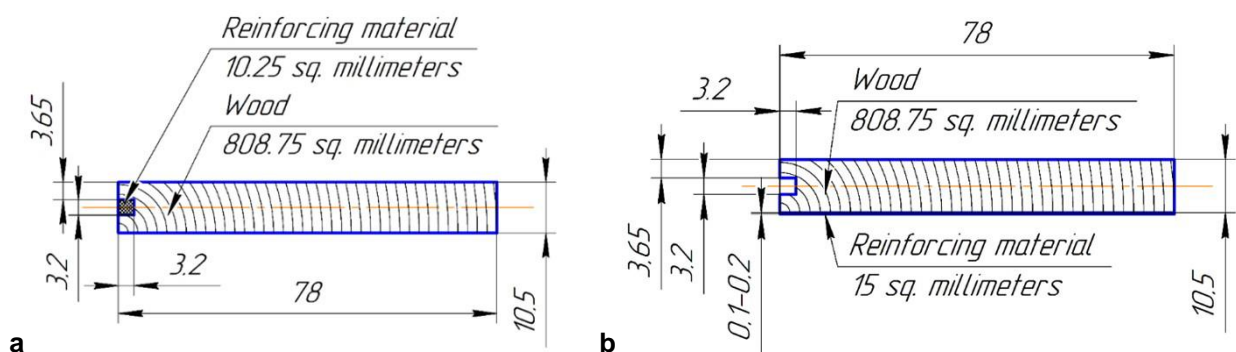
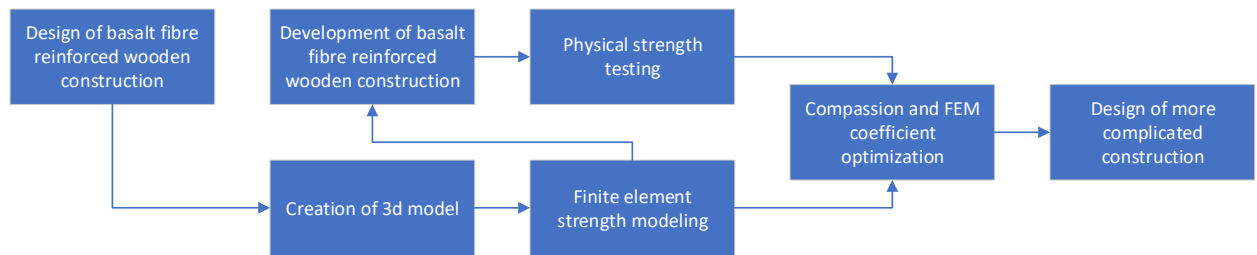

Figure 3. The blueprint of basalt fiber reinforcement (a) and the blueprint of basalt fabric reinforcement (b).

## 2.3. Method of research

The research methodology is shown in Fig. 4. First of all, the most suitable designs for mechanical testing were developed. Minimization of cost was chosen as the main criterion, and therefore, ease of manufacture. The most attractive shapes would be octagons, hexagons, or a 45-degree square. But these shapes are quite laborious to manufacture and reinforce, so the shape of a rectangle with edges located at an angle of 90 degrees was chosen in the form of a frame. The groove for the reinforcing material is performed in a standard operation for woodworking - by sawing in the form of a groove (it is used in the manufacture of lumber of the "lining" brand, which has similar dimensions, which is why the production of

these strips is very cheap) As the materials, as described above, the most the timber available in the north is pine. It does not have outstanding mechanical properties, but is inexpensive, readily available and has few knots. Basalt roving was chosen as a reinforcing material, initially it was planned to use a cord, but it is much worse impregnated with epoxy resin, as well as basalt sheet (for type 2). To fix the basalt roving in the groove of the wood, it was decided to use the epoxy resin described above. The main requirement for the resin is high mobility in the liquid state, for a more uniform impregnation of the roving, and an increase in the area of adhesion to the wood. Due to the large area of adhesion to the wood, the epoxy resin formed a monolithic structure, which added additional strength to the reinforced frames. For frame sizes, normal sizes were used to facilitate the manufacturing process, this is a series of numbers 400, 300, 200, 100. Then structures were created, representing the frames of various types described earlier, as well as digital 3D models, taking into account the materials used. For the wood-to-wood connection and for the epoxy resin-wood connection, the bonded type was used because these surfaces are firmly bonded. Then mechanical tests were carried out, as well as calculation by the finite element method with preliminary tabular characteristics of materials. After that, comparisons and optimization of the coefficients for the calculation model were carried out, and the final design was calculated.



**Figure 4. Research methodology.**

#### 2.4. Mechanical testing

The loading was carried out continuously with a hydraulic jack at a speed of 1 kN/min. The load was measured by an electronic force meter, deflections were measured using dial indicator. Deflections were measured in the middle of the span at three points across the width of the model. Indications were recorded by a camera. The scheme of testing is shown in Fig. 5. and camera record of unloaded and loaded frames are shown in Fig. 6.

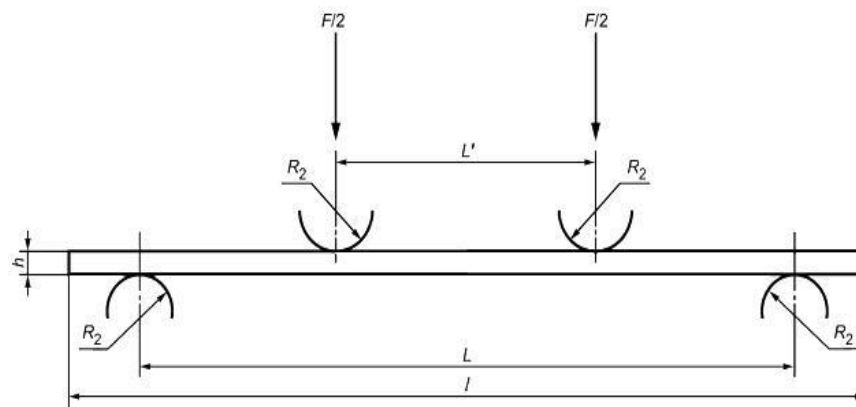

**Figure 5. Load scheme ( $L=1000$  mm;  $L'=333$  mm;  $R_2=50$  mm;  $h=78$  mm).**

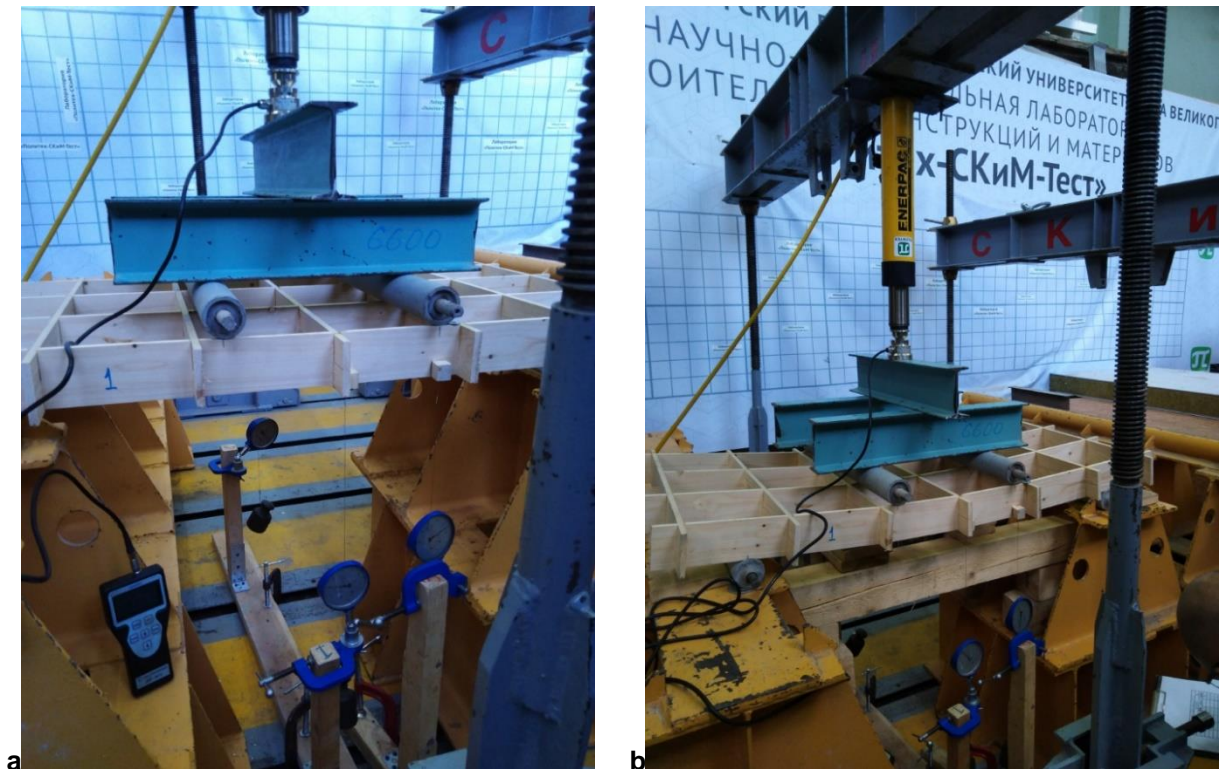

Figure 6. Unloaded frame (a) and loaded frame (b).

### 2.5. Finite element testing

Element modeling was carried out in the Ansys software package, and in the calculation module - static structural. The design scheme is shown in Fig. 7. The loads were set in accordance with the loads on the test bench.

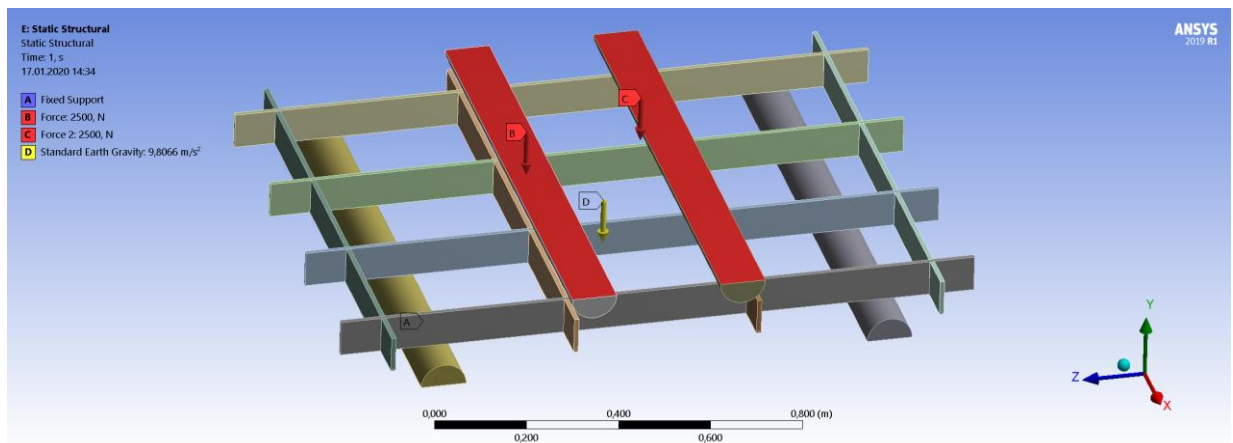
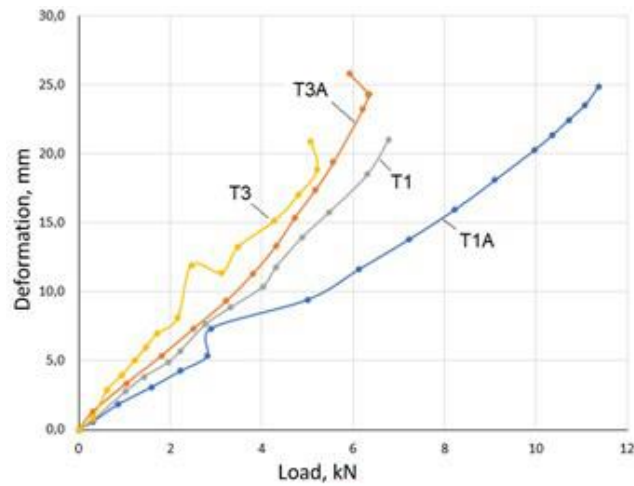

Figure 7. Design scheme and loads for T3A frame.

## 3. Results and Discussions

### 3.1. Testing results

The result of mechanical testing of first type of frames (T1,T3,T1A,T3A) are provided in Fig. 8. Results of T2 does not provided, because, there was not T2A frame. The destruction of the T3 sample occurs at a load of 5.2 kilonewton, with a deformation of 19 mm, while the destruction of the T3A sample occurs at a load of 6.4 kilonewton and a deformation of 24 mm. The destruction of the T1 specimen occurs at a load of 6.8 kilonewton, with a deformation of 22 mm, while the destruction of the T1A specimen occurs at a load of 11.2 kilonewton and a deformation of 25 mm.



**Figure 8. Results of mechanical testing of frames T1, T3, T1A, T3A.**

The destruction of the reinforcement wooden frame occurs immediately after the tear of the reinforcing fiber. Samples of destruction are shown in Fig. 9.

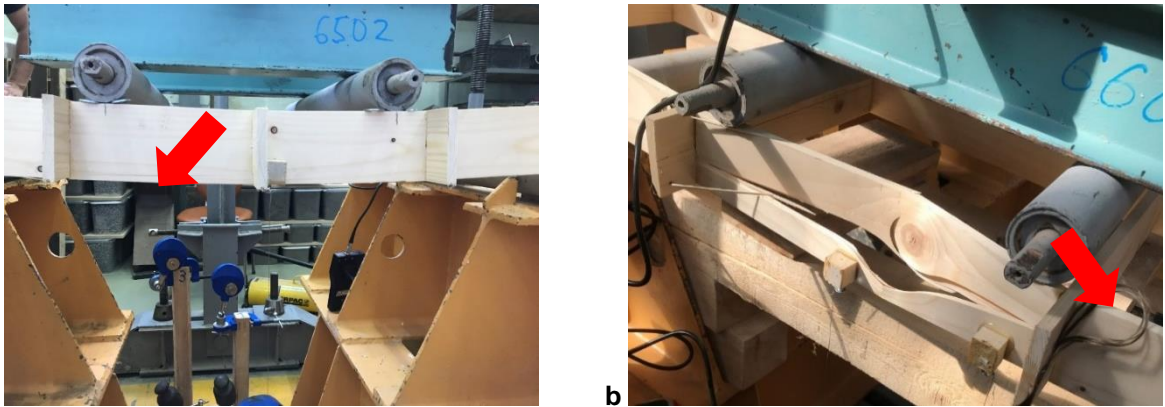

**Figure 9. Crack in the bottom of frame (a), and teared reinforcement material (b), demonstrated by red arrow.**

The result of mechanical testing of second type of frames (T1L7, T2L4, T3L3) are provided in Fig. 10. The destruction of the T1L7 sample occurs at a load of 16.2 kilonewtons, with a deformation of 4 mm, the destruction of the T2L4 sample occurs at a load of 18.6 kilonewtons and a deformation of 6 mm, the destruction of the T3L3 specimen at a load of 12.0 kilonewtons and a deformation of 4.2 mm

Previously, it has found that the strength of basalt reinforced timber increased by 10–15 %, and deflection was reduced 16 %, in the case of glulam [26]. In our case with wooden structures, the properties were improved even more significant. Stiffness or elastic modulus have received a relatively low value with basalt fibre-reinforced polymer [27], [28], addressing to need for further enhancement.

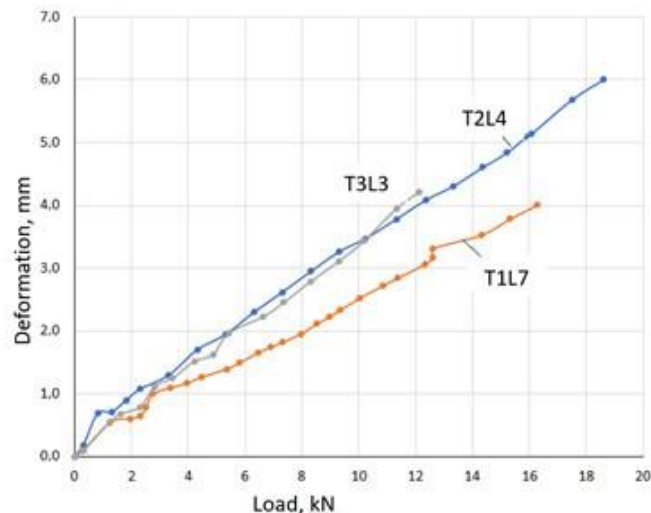

**Figure 10. Results of mechanical testing of frames T1L7, T2L4, T3L3.**

### 3.2. FEM

Finite element modeling of samples T3 (Fig. 11) and T3A (Fig. 12) were carried out with the corresponding materials. The maximum deformations are detectable approximately correspond to those obtained during mechanical tests. Deformations 19 and 19.8 mm for specimen T3, and 17 and 17.1 mm for specimen T3A at a load of 5 kilonewtons. This corresponds to approximately a tensile yield strength of 20 MPa in the base material (wood).

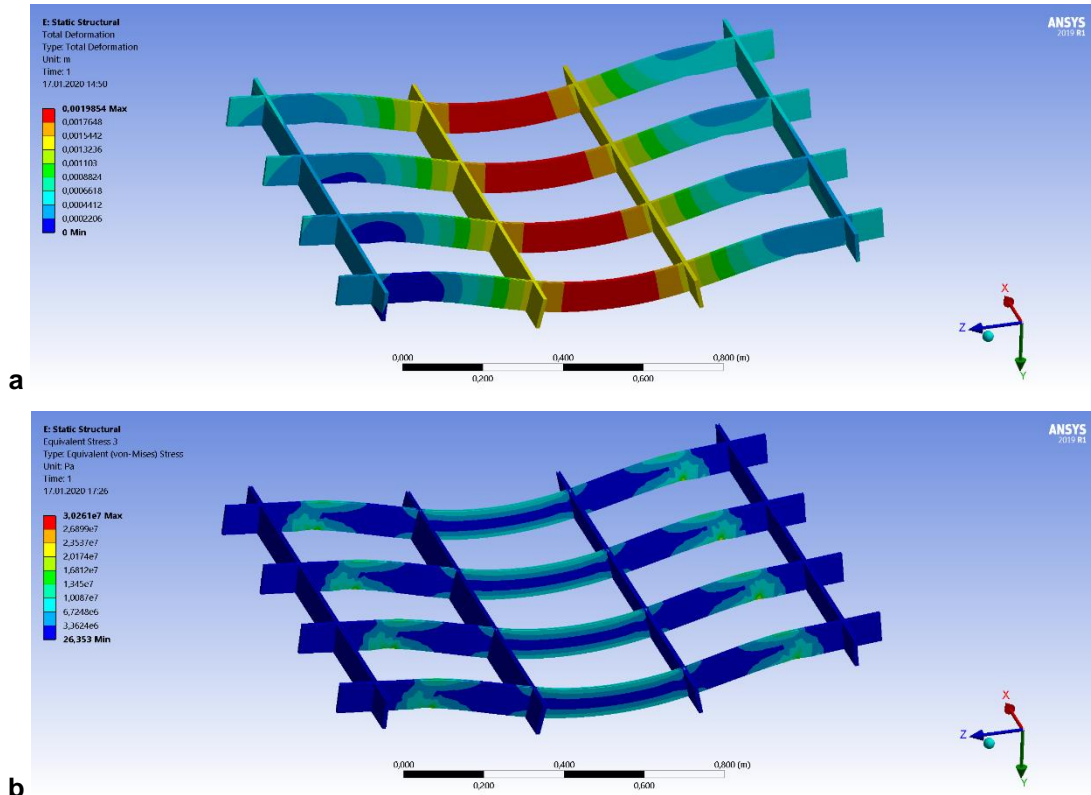

Figure 11. Deformations (a) and von-mises Stress (b) of pure wood frame T3.

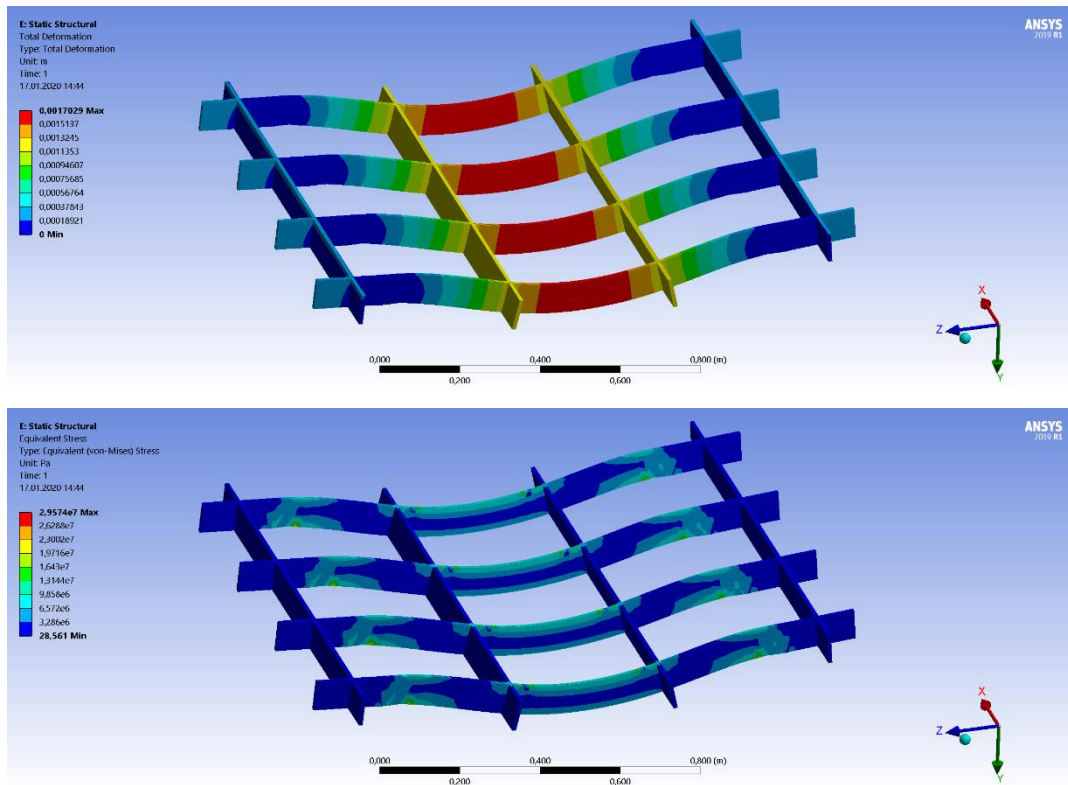

Figure 12. Deformations (a) and von-mises Stress (b) of pure wood frame T3A.

### 3.3. Material Consumption

**Table 1. Property information of studied materials and the features of material from mechanical tests.**

No	Frame name	Frame cell size, mm	Bottom roving reinforcement	Lower laminated planks	Wood Mass, kilograms	Reinforcing material Mass, kilograms	Maximum load, kN	Tensile yield strength, %	Tensile yield Strength per mass
1	T1	100x100	no	no	6.55	0	6.6	100	1.01
2	T2	200x200	no	no	3.64	0	5.6	100	1.54
3	T3	300x400	no	no	2.43	0	5.2	100	2.14
4	T1A	100x100	yes	no	6.55	0.22	11.2	170	1.65
5	T3A	300x400	yes	no	2.43	0.08	6.2	119	2.47
6	T1L7	100x100	no	7	13.34	0.17	16.2	245	1.20
7	T2L4	200x200	no	4	8.98	0.10	18.4	329	2.03
8	T3L3	300x400	no	3	7.28	0.07	12	231	1.63

The studied materials, are listed in Table 1, including also the results of mechanical strength test by different parameters. The information in Table 1 show that the studied materials were quite heterogenous, indicating that several aspects will be accounted in this study, which again increase the reliability of done work. The ability of wooden frame to carry load will increase when frame was reinforced, but naturally, the density of materials influences the strength, as “strength per mass” demonstrated.

### 4. Conclusion

In this article, the results of mathematical and physical modeling of structures using combined materials (wood, basalt roving, basalt canvas, epoxy) were presented. The research results showed that structures made of combined materials show increased strength on the influence of external factors. And thus, we can conclude that the applicability of these materials and structures for the construction of wooden structures.

With a minimum amount of wood and a minimum reinforcement (sample T3A), an increase in strength of 19 % is achieved, with a minimum cost of reinforcing material, and destruction occurs at a load of 6.4 kilonewtons with a deformation of 24 mm, in contrast to the original sample T3, the destruction of which occurs under load at 5.2 kilonewtons and deformation of 19mm, which makes it, with a weight of 2.43 kg, almost equal in strength to the sample T1, weighing 6.55 kg. For specimen T1A, the reinforcement leads to an increase in strength by 70%, and fracture occurs at a load of 11.2 kilonewtons with a deformation of 25 mm, in contrast to the original specimen T1, which fractures at a load of 6.8 kilonewtons and a deformation of 22 mm.

Laminated samples show even more impressive results, The destruction of the T1L7 sample occurs at a load of 16.2 kilonewtons, with a deformation of 4 mm, the destruction of the T2L4 sample occurs at a load of 18.6 kilonewtons and a deformation of 6 mm, the destruction of the T3L3 specimen at a load of 12.0 kilonewtons and a deformation of 4.2 mm. But at the same time, these samples are much more material-intensive and heavy: 7.28 kg for sample T3L3, 8.98 kg for sample T2L4 and 13.34 kg for sample T1L7.

In the light of the results, the improved properties of materials encourage researchers to continue studies in this field and for example, various material amounts and those combination should be studied more exactly in future. Also, other mechanical tests could describe the nature of material wider, such as impact strength that describing a momentary strain for material or stiffness that implies the momentary maximum force whereof deformations will return after the load is removed. In addition, the whole effect of treatments on the environment could be analyzed, such as life cycle assessment.

### References

1. Morseletto, P. Targets for a circular economy. Resources, Conservation and Recycling. 2020. 153. Pp. 104553. DOI: 10.1016/j.resconrec.2019.104553. URL: <http://www.sciencedirect.com/science/article/pii/S0921344919304598>.
2. Toppinen, A., Röhr, A., Pätäri, S., Lähtinen, K., Toivonen, R. The future of wooden multistory construction in the forest bioeconomy – A Delphi study from Finland and Sweden. Journal of Forest Economics. 2018. 31(1). Pp. 3–10. DOI: 10.1016/j.jfe.2017.05.001.
3. Guardigli, L., Monari, F., Bragadin, M.A. Assessing Environmental Impact of Green Buildings through LCA Methods: A comparison between Reinforced Concrete and Wood Structures in the European Context. Procedia Engineering. 2011. 21. Pp. 1199–1206. DOI: 10.1016/j.proeng.2011.11.2131. URL: <http://www.sciencedirect.com/science/article/pii/S1877705811049654>.



4. Ramage, M.H., Burrige, H., Busse-Wicher, M., Fereday, G., Reynolds, T., Shah, D.U., Wu, G., Yu, L., Fleming, P., Densley-Tingley, D., Allwood, J., Dupree, P., Linden, P.F., Scherman, O. The wood from the trees: The use of timber in construction. *Renewable and Sustainable Energy Reviews*. 2017. 68. Pp. 333–359. DOI: <https://doi.org/10.1016/j.rser.2016.09.107>.
5. Fleming, P., Smith, S., Ramage, M. Measuring-up in timber: a critical perspective on mid-and high-rise timber building design. *arq: Architectural Research Quarterly*. 2014. 18(1). Pp. 20–30.
6. Mallo, M.F.L., Espinoza, O. Cross-Laminated Timber vs. Concrete/steel: Cost comparison using a case study. *WCTE 2016–World Conference on Timber Engineering*. 2016.
7. Meier, U. Strengthening of structures using carbon fibre/epoxy composites. *Construction and Building Materials*. 1995. 9(6). Pp. 341–351.
8. Wang, J., Yang, Y., Hu, L., Zhuang, R. Experimental study on bond-slip behavior between bfrp and wood [J]. *Fiber Reinforced Plastics/Composites*. 2009. 3.
9. Richard Avent, R. Decay, weathering and epoxy repair of timber. *Journal of Structural Engineering*. 1985. 111(2). Pp. 328–342.
10. Chen, Z., Huang, Y. Mechanical and interfacial properties of bare basalt fiber. *Journal of Adhesion Science and Technology*. 2016. 30(20). Pp. 2175–2187. DOI:10.1080/01694243.2016.1174510.
11. Borri, A., Corradi, M., Speranzini, E. Reinforcement of wood with natural fibers. *Composites Part B: Engineering*. 2013. 53. Pp. 1–8.
12. de la Rosa García, P., Escamilla, A.C., García, M.N.G. Bending reinforcement of timber beams with composite carbon fiber and basalt fiber materials. *Composites Part B: Engineering*. 2013. 55. Pp. 528–536.
13. Raftery, G.M., Kelly, F. Basalt FRP rods for reinforcement and repair of timber. *Composites Part B: Engineering*. 2015. 70. Pp. 9–19.
14. Righetti, L., Corradi, M., Borri, A. Basalt FRP spike repairing of wood beams. *Fibers*. 2015. 3(3). Pp. 323–337.
15. Chen, W., Pham, T.M., Sichebe, H., Chen, L., Hao, H. Experimental study of flexural behaviour of RC beams strengthened by longitudinal and U-shaped basalt FRP sheet. *Composites Part B: Engineering*. 2018. 134. Pp. 114–126.
16. Guojun, L.U., Weihong, W., Shijie, S. Mechanical properties of wood flour reinforced high density polyethylene composites with basalt fibers. *Materials Science*. 2014. 20(4). Pp. 464–467.
17. Sarasini, F., Tirillò, J., Valente, M., Ferrante, L., Cioffi, S., Iannace, S., Sorrentino, L. Hybrid composites based on aramid and basalt woven fabrics: Impact damage modes and residual flexural properties. *Materials & Design*. 2013. 49. Pp. 290–302.
18. Dhand, V., Mittal, G., Rhee, K.Y., Park, S.-J., Hui, D. A short review on basalt fiber reinforced polymer composites. *Composites Part B: Engineering*. 2015. 73. Pp. 166–180.
19. de la Rosa García, P., Escamilla, A.C., García, M.N.G. Analysis of the flexural stiffness of timber beams reinforced with carbon and basalt composite materials. *Composites Part B: Engineering*. 2016. 86. Pp. 152–159.
20. Bodig, J., Jayne, B.A. *Mechanics of wood and wood composites*. 712. Van Nostrand Reinhold New York, 1982.
21. Fragiacomò, M., Ceccotti, A. Long-term behavior of timber–concrete composite beams. I: Finite element modeling and validation. *Journal of structural engineering*. 2006. 132(1). Pp. 13–22.
22. Dias, A., Van de Kuilen, J.W., Lopes, S., Cruz, H. A non-linear 3D FEM model to simulate timber–concrete joints. *Advances in Engineering Software*. 2007. 38(8–9). Pp. 522–530.
23. Oudjene, M., Meghlat, E.M., Ait-Aider, H., Lardeur, P., Khelifa, M., Batoz, J.L. Finite element modelling of the nonlinear load-slip behaviour of full-scale timber-to-concrete composite T-shaped beams. *Composite Structures*. 2018. 196. Pp. 117–126.
24. Hassanieh, A., Valipour, H.R., Bradford, M.A., Sandhaas, C. Modelling of steel-timber composite connections: Validation of finite element model and parametric study. *Engineering Structures*. 2017. 138. Pp. 35–49.
25. Kozinec, G.L. Generalization of the Methodology of Studying the Durability of Segmental Gates. *Power Technology and Engineering*. 2018. 52(4). Pp. 395–399.
26. Zhang, P., Shen, S. Strengthening mechanical properties of glulam with basalt fiber. *Advances in Natural Science*. 2011. 4(2). Pp. 130–133.
27. McConnell, E., McPolin, D., Taylor, S. Post-tensioning glulam timber beams with basalt FRP tendons. *Proceedings of the Institution of Civil Engineers-Construction Materials*. 2015. 168(5). Pp. 232–240.
28. Lopresto, V., Leone, C., De Iorio, I. Mechanical characterisation of basalt fibre reinforced plastic. *Composites Part B: Engineering*. 2011. 42(4). Pp. 717–723. DOI: <https://doi.org/10.1016/j.compositesb.2011.01.030>.
29. Klyuev, S.V., Klyuev, A.V., Khezhev, T.A., Pukhareno, Y. High-strength fine-grained fiber concrete with combined reinforcement by fiber. *Journal of Engineering and Applied Sciences*. 2018. 13. Pp. 6407–6412.
30. Fediuk, R.S., Lesovik, V.S., Liseitsev, Yu.L., Timokhin, R.A., Bituyev, A.V., Zaiakhanov, M.Ye., Mochalov, A.V. Composite binders for concretes with improved shock resistance. *Magazine of Civil Engineering*. 2019. 85(1). Pp. 28–38. DOI: 10.18720/MCE.85.3.
31. A D Tolstoy; V S Lesovik; E S Glagolev; A I Krymova. Synergetics of hardening construction systems. *IOP Conference Series: Materials Science and Engineering*. 2018. 327(3). 032056. doi: 10.1088/1757-899X/327/3/032056
32. Badenko, V., Fedotov, A., Zotov, D., Lytkin, S., Volgin, D., Garg, R.D., Min, L. Scan-to-bim methodology adapted for different application. *International Archives of the Photogrammetry, Remote Sensing and Spatial Information Sciences - ISPRS Archives*. 2019. 42(5/W2). Pp. 1–7.

### **Contacts:**

*Galina Kozinetc, galina4410@yandex.ru*

*Timo Kaarki, Timo.Karki@lut.fi*

*Yuriy Barabanshchikov, ugb@mail.ru*

*Ville Lahtela, Ville.Lahtela@lut.fi*

*Dmitry Zotov, zotovdk@gmail.com*

© Kozinetc K.G.,Kaarki T.,Barabanshchikov Yu.G.,Lahtela V.,Zotov D. K., 2020