



DOI: 10.34910/MCE.102.1

Bearing capacity of eccentrically compressed bisteel columns

S.I. Evtushenko^{a*}, I.A. Petrov^b, M.N. Shutova^b, B.A. Chernykhovskiy^b

^a Moscow State University of Civil Engineering (National Research University), Moscow, Russia

^b Platov South-Russian State Polytechnic University (NPI), Novocherkassk, Russia

*E-mail: evtushenkosi@mgsu.ru

Keywords: ultimate load, eccentric compression, numerical analysis, structural analysis, finite element, thin-walled rod, thin-walled bar, bisteel column

Abstract. Article is devoted to calculation the bisteel non-central compressed columns from I-shaped profile. The web of I-shaped profile is made of structural steel, the flanges is made from increased-durability steel. The analytical decision used the system of the equations was applied. Also, physical tests of prototypes on the prof. Korobov's testing machine were carried out. Loading is applied eccentrically to a steel plate, the hinge support applied to the lower plate, plates are fixed by screws from rotational translations. Displacements on axes are measured in the plane of the section in middle of rack and also occurs tilt angles. Calculation in ANSYS software taking into account physical and geometrical nonlinearity is carried out. It is established that analytical calculation gives the results close to experimental values (the maximum divergence of 15 %), the configuration of schedule of ANSYS simulation results repeats the schedule of experience data, and a divergence of results is insignificant (to 9 %).

1. Introduction

In sections with non-central loaded buildings constructions arise various tension, at the same time a part of section is used ineffectively. The idea to use in the loaded parts of section high-strength metal is effective as it allows using optimum sections – in places with big tension steel with a high durability is applied.

The possibility of application the bisteel constructions were analyzed by several scientists in Russia and abroad.

Authors [1] made using comparison of bridges load-bearing element working in seismic zones. A part of constructions it was executed as bisteel.

In a [2] research of a bend of the two-layers steel beam (steel with normal and high-strength durability) shown, that the normal stresses in multilayer beams depend on the bending stiffness's relative to the principal axes of cross sections of the beams.

A similar analysis with bisteel profile was made with bisteel beam (a composition of high-strength steel inclusions for the flanges in the region of maximum stresses and of low-strength steel for remaining volume of the beam) [3].

In the [4] article analyzes the stability of bisteel beams taking into account the development of plastic deformation in one or more cross-sectional elements.

Calculation of section of bisteel beams was carried out also using ANSYS complex [5]. Quantitative assessment of the phenomenon of a delay of the beginning of fluidity of the elastic-plastic zones of a wall adjoining elastic belts is received.

The authors of [6] performed experimental and numerical modeling of bending and torsion behavior and bearing capacity of columns from an equal-angle L-shape column of hot-rolled austenitic steel with a fixed end.

The authors of [7] conducted a comprehensive experimental and numerical study of the behavior of welded stainless-steel beam-columns. Twenty test specimens were made of duplex plates; they were tested



for bending with compression. Tensile tests and geometric defects were also conducted. Numerical models were developed, calibrated according to test results and subsequently used in parametric studies, taking into account a wider range of sample geometries.

The authors of [8] studied the properties of a rack made of square steel pipes filled with concrete with a cross section in the L-shape. Using two eccentric compression experiments, the fracture mode, load displacement curves for the entire element, and deflection curves for the rack were obtained.

The authors of [9] experimentally and numerically investigated the bending behavior of welded steel I-beams under eccentric compression.

The authors of [10] studied the mechanical properties of a steel L-shape column rigidly fixed with one support. The influence of the plate thickness and the number of bolts on the bearing capacity was analyzed.

The authors of [11] performed an experimental study to assess the effect of vertical soil movement on steel columns with wide flanges in the lower floors of steel frames. Three cyclic side load tests were performed.

The authors of [12] conducted a numerical study of columns made of high-strength steel plates. The study included 4 reference models, confirmed by test data, and parametric research models.

The authors of [13] tested 28 steel L-shape specimens to study their reaction when it is necessary to withstand the axial compressive load at different end eccentricities.

The authors of [14] investigated the stability and design of laser-welded stainless-steel I-beam columns.

In [15], the authors conducted an experimental study on the ultimate strength of welded I-beams made of steel using laser cutting under axial compression.

The methodology for calculating centrally and eccentrically compressed non-ideal rods of a rectangular profile in critical and supercritical states is described in the [16], in which the principle of possible displacements was used as the calculation method.

The authors of [17] proposed variants of linearized differential equations of “geometrically” and “physically” nonlinear problems on bending-torsional deformations of thin-walled open-profile rods. Two “step-by-step” methods for solving the original nonlinear problem are considered. General expressions are obtained for the formation of sequentially refined stiffness matrices of rods as systems with 14 degrees of freedom with the possibility of introducing them into the finite element method programs when calculating bar nonlinearly deformable structures.

The solution of the problem of determining the bearing capacity and stability of compressed rods is urgent. Many authors offer various methods, some of which use the calculus of variations [18–19].

Many scientific works provide examples of determining the bearing capacity of beam and column structures by analytical and numerical methods [20–24].

The purpose of this study is to compare the results (the dependence of the axial displacements of the mid-section) of the calculation of the eccentrically loaded bisteel column using the analytical and numerical method of solution, and also to prove their comparability with the experimental results.

2. Methods

2.1. Analytical method

Bisteel columns are effective constructions in comparison with traditional monosteel standard structures: the bearing capacity of section increases due to elastic-plastic work and a favorable combination of various durability of steel.

At production welded I-shaped profiles residual tension influence were arisen. Their influence on the intense deformed condition of thin-walled elements of metal designs is studied insufficiently. Calculation methods were developed for bisteel elements of metal constructions beyond an elasticity limit.

Algorithms of finding of maximum loads of non-central compressed welded the bisteel columns are developed, considering residual welding tension and elastic-plastic deformations.

According to project codes calculation of the compressed elements of steel metal structures consists of:

- selection of the sizes of cross section providing the set service conditions at and minimum cost;
- check of durability;
- check of rigidity;
- check of general stability and also stability of elements of cross section.

Feature of work of non-central compressed columns with two-axis eccentricity is the development of all three characteristic deformations (deflections in two planes and the angles of twisting).

For the analysis of the intense deformed condition of thin-walled elements at elastic-plastic deformations used the charts of balance conditions connecting the internal forces of a profile with its displacements.

Searching of the limit parameter of the load N (loss of bearing capacity) provides by step method. N_{lim} is a load from requirement of first and second group of limiting condition.

The conducted researches are based on the system of the differential equations of a bend and torsion of thin-walled cores of open profile with the geometrical and physical nonlinearity, offered by A.Z. Zarifyan [25]. The decision of a boundary-value problem based on method of "elastic solution", developed by A.A. Ilyushin.

For analyses pendulum column (H-shape form), compressed by longitudinal force N , having an eccentricity e_x, e_y (shown on Fig. 1) using system of the differential equations (1):

$$\left\{ \begin{array}{l} EA\zeta_t'' = q_{z\psi,t}; \\ EI_y\xi_t^{IV} + (1 - \frac{I_y}{I_x})(M_x\theta_t)'' + N\xi_t'' = q_{x\psi,t} \\ EI_x\eta_t^{IV} + (1 - \frac{I_x}{I_y})(M_y\theta_t)'' + N\eta_t'' = q_{y\psi,t}; \\ EI_\omega\theta_t^{IV} - GI_{tor}\theta_t'' + M_x\xi_t'' + M_y\eta_t'' + \frac{I_y + I_x}{A}N = m_{\psi,t} \end{array} \right. \quad (1)$$

where $q_{z\psi,t}, q_{x\psi,t}, q_{y\psi,t}, m_{\psi,t}$ are intensity of additional distributed loading in the plasticity zone, which depends on the propagation of the plastic strain zones along the cross section and the length of the rod. The additional load functions were determined from the formulas:

$$q_{z\psi} = N_\psi; q_{x\psi} = (M_{y\psi})''; q_{y\psi} = -(M_{x\psi})''; m_{\psi} = B_\psi, \quad (2)$$

where $N_\psi, M_{x\psi}, M_{y\psi}, B_\psi$ are partial values of internal forces in the zones of plastic deformations of the rod's cross sections, arising from the difference between the elastic and effective stresses, according to the actual diagrams of deformation of the materials of the column elements ($\sigma_i - \varepsilon_i$). In the absence of plastic deformations in the sections, we consider these quantities to be equal to zero. A detailed description of the algorithm for determining the bearing capacity for eccentrically compressed rods, taking into account the geometric and physical nonlinearity, is given in [26].

In the general case, the algorithm for solving the system of nonlinear differential equations was implemented as follows:

- at the first step, the plasticity function $\psi_1(\varepsilon_i)$, the intensity of the additional loads $q_{x\psi,1}, \dots$, as well as the additional forces in the boundary sections $M_{x\psi,1}, \dots$ are set equal to zero and a system of linearized ordinary differential equations was solved. At the next stage, the values of the displacement functions $\zeta_1, \xi_1, \eta_1, \theta_1$ were determined, the strain intensities $\varepsilon_{i,1}$ were calculated, the zones of plasticity propagation over the cross sections and the length of the thin-walled rod were found.
- taking into account the nature of the diagrams $\sigma_{if} = \sigma_{if}(\varepsilon_i)$ for the shelf and $\sigma_{iw} = \sigma_{iw}(\varepsilon_i)$ for the column wall, the stress intensities σ_i , the plasticity function $\psi_2(\varepsilon_i)$ were found and the quantities the development of plastic areas, the values $q_{x\psi,2}, \dots$ and $M_{x\psi,2}, \dots$. The rod, in addition to the given external forces, was loaded with additional distributed loads $q_{x\psi,2}, \dots$ in the span along the elastoplastic region and additional forces $M_{x\psi,2}, \dots$ at the ends. Since the expressions $q_{x\psi,2}, \dots, M_{x\psi,2}, \dots$ were determined by substituting the corresponding formulas for the displacement functions of the previous approximation into nonlinear terms, a system of linear differential equations was obtained.

The calculation in the third and following approximations was reduced to the sequential solution of linear equations.

The system of differential equations (1) for calculating elastoplastic thin-walled rods of an open profile is obtained on the basis of the following premises:

- the projection of the contour of the cross section on the accompanying plane normal to the deformed axis of the centers of bending of the rod is not distorted;
- shear deformations of the middle surface are insignificant, and their influence on the law of distribution of longitudinal displacements along the midline of the contour can be neglected;
- normal stresses in the cross section are considered uniformly distributed over the thickness;
- tangential stresses τ_{zs} are directed parallel to the tangent to the midline and along the thickness of the profile elements and vary linearly.
- for rods made of elastoplastic materials, under simple loading, the dependence between the stress intensity σ_i and the strain rate ε_i is taken in the form $\sigma_i = E [1 - \psi(\varepsilon_i)] \varepsilon_i$, where $\psi(\varepsilon_i)$ is a function depending on the achieved level of strain intensity and determined from the diagram $\sigma_i - \varepsilon_i$ of the material;
- with simple loading in the rods of elastoplastic materials, there is a continuous increase in the strain intensity;
- the relationship between deformations and components of the displacement vector has the form

$$\varepsilon_z = \zeta' - (\zeta'' + \theta \eta'') x - (\eta'' - \theta \zeta'') y - \theta' \omega.$$

- to determine the boundaries of the distribution of plastic zones over cross sections and the length of a thin-walled rod, the Mises plasticity condition was adopted. The transition of the rod to the elastoplastic state occurs when the stress intensity value in the most stressed fibers becomes equal to the yield strength of the material $\sigma_i = \sigma_y$.

At non-central compression with the two-axis eccentricity identical on both ends, kinematic boundary conditions for ζ, η, θ do not change and depend on a way of fixing of a core. Internal efforts in the case of the development of plastic deformations in the main sections when the force N is transmitted to the ends of the rod through diaphragms that are rigid from their plane (the absence of an external bimoment at the ends) have the form:

$$\xi = \eta = \theta = 0, \quad M_x = Ne_y - M_{x\psi}, \quad M_y = -Ne_x - M_{y\psi}, \quad B = Ne_x e_y - B_{\psi}.$$

The calculation results using formulas (1), (2) are shown on diagram, Fig. 6, denote by green color.

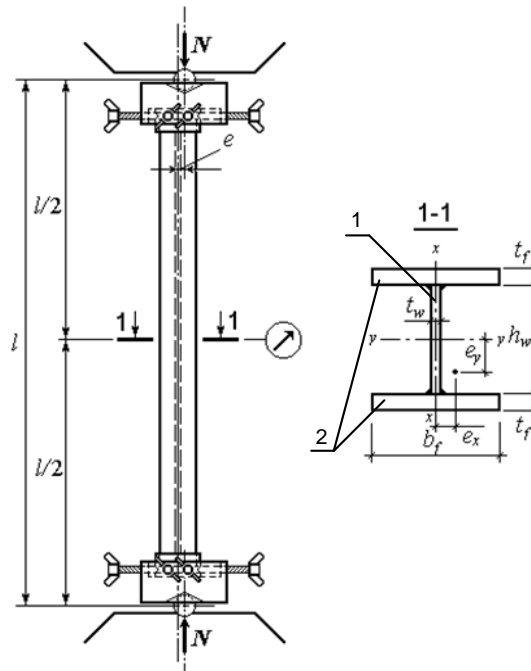

**Figure 1. The design scheme of column and cross section:
1 – normal-strength steel; 2 – high-strength steel.**

Table 1. Parameters of the studied specimens.

№ of rack	Name	Geometrical values				Design loadings N , kN	Slenderness λ_y	Length l , cm
		h_w , mm	b_f , mm	t_w , mm	t_f , mm			
1	2	8	9	10	11	13	14	15
1	KM 1-01	62	61	2	2	34.0	60	85.5
2	KM 1-02	63	60	2	2		61	--
3	KB 1-03	42	38	2	4.5	23.0	96	94
4	KB 1-04	41	39	2	4.5		94	--
5	KB 2-01	26	45	2	4.5		85	105
6	KB 2-02	27	44	2	4.6	24.5	88	--
7	KB 2-03	25	45	2	4.5		85	--
8	KB 2-04	27	45	2	4.6		86	--

Note: KM is monosteel rack; KB is bisteel rack.

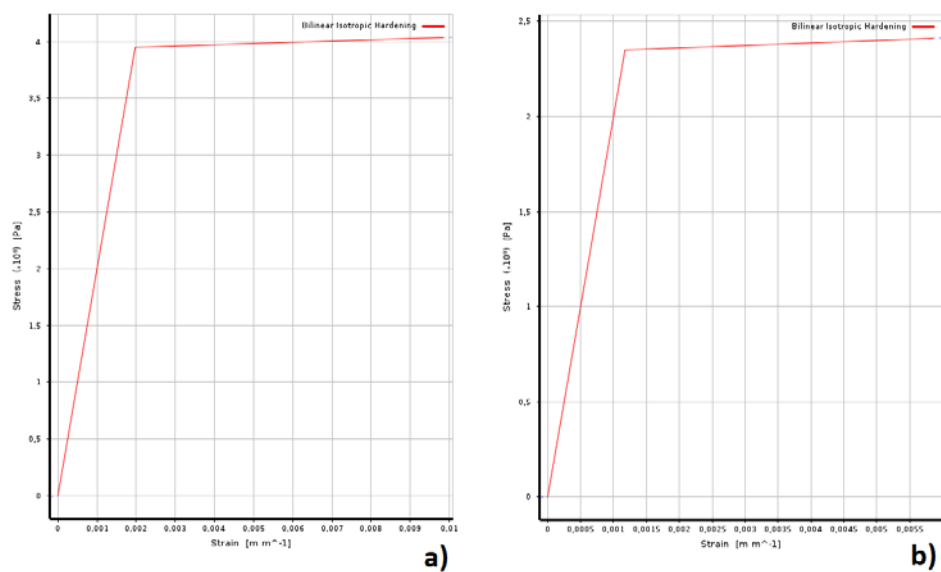

Figure 2. Bilinear isotropic hardening chart: a – 09G2; b – VSt3sp5.

2.2. Experimental method

Testing of welded I-shaped rack by compression with an eccentricity [27] relative to both main axes were carried out on special test unit based on 10-ton unit used prof. Korobov's system (Fig. 3).

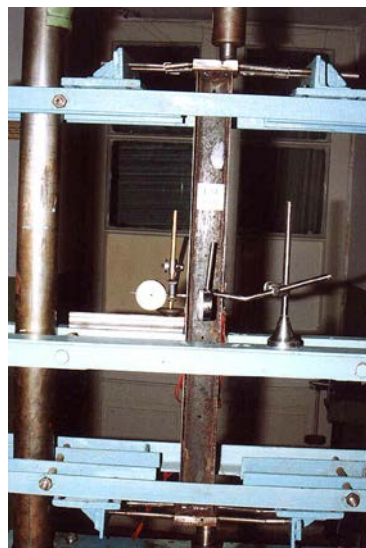

Figure 3. Overall view of test unit.

The optimal sizes of the experimental bisteel pillar columns were calculated using the multicriteria multiparameter optimization of the cross-sectional dimensions of eccentrically compressed rods, the material of which works in the elastoplastic stage [17].

The following materials were used for the rack:

- webs of the I-beam profile were made from sheet broadband universal hire of the brand VSt3sp5 (Russian State Standard GOST 27772-88*) with design resistance $R_{y,w} = 235$ MPa,
- flanges of the I-beam profile were made from high-strength steel of the brand 09G2 (Russian State Standard GOST 19282-73*) and 14G2 with design resistance $R_{y,f} = 355$ MPa.

The columns were welded by semi-automatic welding in carbon dioxide. To make the shape and dimensions of the posts after welding consistent with the design, a number of measures were taken during their manufacture, which were reduced to compensate for the plastic deformation that develops during welding. These included the following:

- increase in stiffness by means of special fastenings of the elements being welded (use of a conductor);
- application of a rational order of welding.

The ends of the strut elements were milled to obtain a flat supporting surface.

It was made 8 racks of two series. Each series consisted of 4 samples. After manufacturing, each rod was measured in three sections along the length using a caliper. The scatter of measurements was no more than 1.6 %, which made it possible to use all the characteristics.

To obtain a diagram σ – ε of the material of the shelves and walls, flat samples were made, which were subjected to tension up to fracture. In the elements (wall and shelves) of the H-shaped profile of sheet metal, the samples were oriented in the direction of the greatest compressive stresses in the column. Production of samples and their tensile tests were carried out according to Russian State Standard GOST 1497-84*.

Testing of all rods for eccentric compression was carried out according to a single method. The full test cycle of each rod in the elastic and elastoplastic stages included the preparatory stage and the test phase. At the preparatory stage, after the final centering, the rod was installed in the supporting devices of the machine with the specified eccentricities of the load application and the measuring devices were mounted.

The eccentricities e_x , e_y of the application of the load were created due to the displacement of the axis of the rack relative to the axes of the loading device of the testing machine. The magnitude and sign of the eccentricities at both ends of the rod were assumed to be the same. After obtaining the specified eccentricity of the load application, eccentric loading was performed by the applied force.

The following measurements were made on the tests:

- displacement of the center of a bend (ξ , η) in the direction of axes OX and OY in the central section of the column (were installed dial indicators with an increment of 0.01 mm);
- deformation in the middle of the rack using strain gauges with a base of 10 mm and strain gauge station VST-6. The device provided measurement of longitudinal deformations with an accuracy of $1 \cdot 10^{-5}$ and allowed to define relative deformations up to 2 %;
- bearing capacity (it was fixed according to indications of a dynamometer).

The tests results are shown on diagram, Fig. 7, denoted by red color.

2.3. Finite element modelling method

Finite element model of rack was calculated by ANSYS software. Authors found that the divergence between the calculation and experimental results for the tested rack in the linearity zone is on average 3.39 % [28]. Computer analysis of the data allows obtaining the results of deformation of an eccentrically compressed column without full-scale experiment.

The model consists of: steel plate with design resistance $R_{y,w} = 235$ MPa (web of I-beam); steel plates with design resistance $R_{y,f} = 355$ MPa (flange of I-beam); prisms (welded seams); heavy plate (upper plate has a load, lower plate has a fixing surface); constraints by side screws (Fig. 4).

The finite element model consists of tetrahedral (lower and upper plates) and hexahedral (the rest of the model) elements with a minimum size of 1–2 mm near the boundary conditions or contact interaction. For extended and geometrically unchanged sections of the structure, a bias modifier is used, which allows to reduce the number of elements in the model without losing the accuracy of the calculation results (Fig. 5).

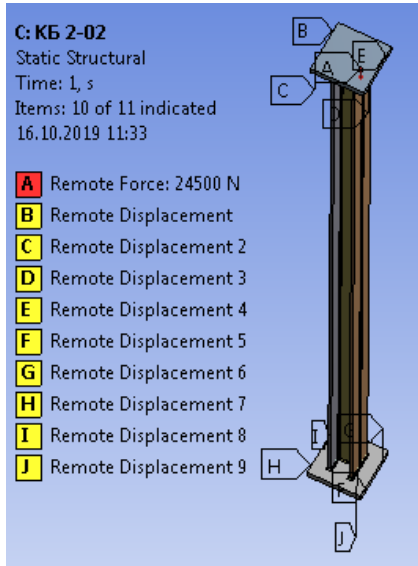

Figure 4. The design model of I-shape form profiles.

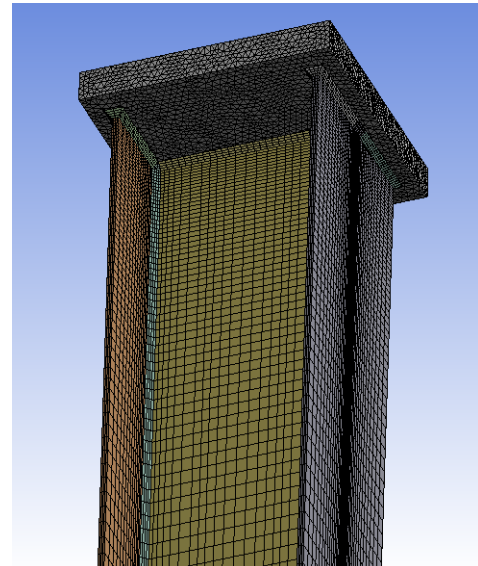
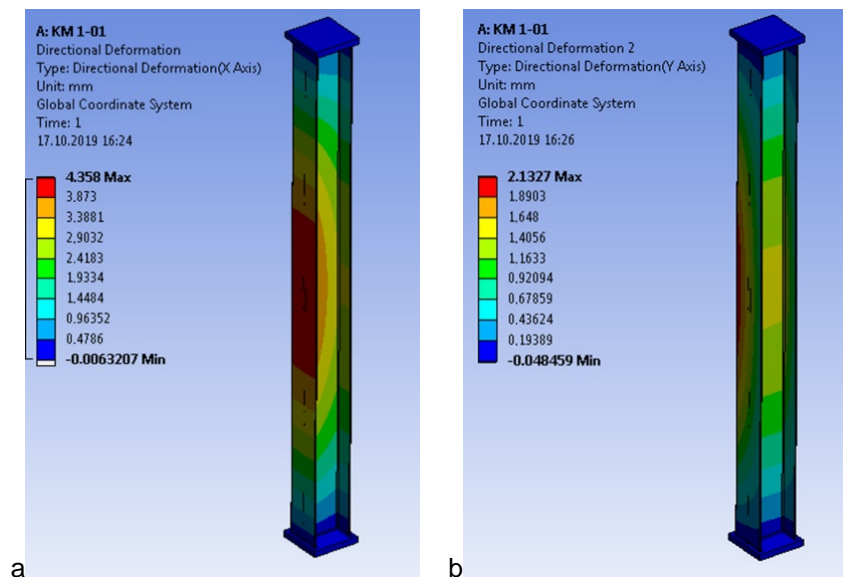

Figure 5. Biased mesh.

The calculation was carried out in a nonlinear formulation. Such a statement implies an iterative type of solution. This means that the conditional loading time is divided into substeps, in each of which the load applied to the structure increases sequentially to the nominal value, the design scheme changes due to deformations (geometric non-linearity), and the elastic properties of the material also change when the stresses leave the proportional band (physical nonlinearity).

3. Results and Discussion

The resulting contours of the values of the directional deformations are represented in Fig. 6.



**Figure 6. Directional deformation:
a – in the direction of axis Ox, b – in the direction of axis Oy.**

All results are represented in Table 1 and on the Fig. 7.

Table 2. Results of analytical solution, tests and computer simulation.

Loading, kN	5	10	15	20	25	30	32
Deformation in the direction of axis OX							
Tests results	0.052	0.114	0.179	0.271	0.486	0.75	0.84
Results of calculation by (1), (2)	0.052	0.103	0.164	0.244	0.4	0.63	0.79
Nonlinear Finite Element Analysis	0.051	0.102	0.154	0.206	0.257	0.308	–
Deformation in the direction of axis OY							
Tests results	0.06	0.126	0.196	0.269	0.371	0.56	0.61
Results of calculation by (1), (2)	0.06	0.126	0.205	0.298	0.44	0.662	0.79
Nonlinear Finite Element Analysis	0.059	0.12	0.18	0.24	0.299	0.36	0.382

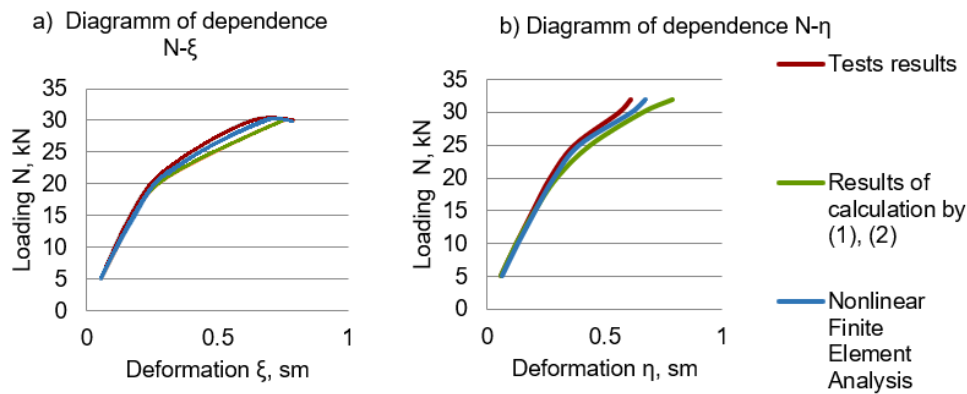

Figure 7. Diagramms of results: a – diagramm of dependence $N-\xi$ (in the direction of axis OX), b – diagramm of dependence $N-\eta$ (in the direction of axis OY).

Analytical calculation for formulas (1) and (2) gives the results close to experimental values (the maximum divergence of 15 %), the configuration of schedule of ANSYS simulation results repeats the schedule of experience data, and a divergence of results insignificant (to 9 %). In the analytical calculation, linear displacements in the direction of the main axes of inertia of the cross section and angular displacements relative to the axis of the column were taken into account. Linear deformations are given in the results of the analytical solution. Under the given boundary conditions corresponding to the parameters of the physical model, total angular displacements in the numerical experiment were less than 0.1 degrees. In a physical experiment, torsional strains were not measured [26]. Thus, it is possible to draw a conclusion on adequacy of computer calculation for the solution of a difficult nonlinear problem. Methods for determining bearing capacity were used to optimize the cross-sectional size of thin-walled rods.

The calculation module for determining the bearing capacity was used to solve the problem of multicriteria optimization of the parameters of the cross section of the bisteel column, taking into account geometric and physical nonlinearity. Optimization was carried out at given values of the column length and compressive force, which was applied with eccentricities. The solution to the optimization problem was based on a search method in a uniformly distributed sequence. The following parameters were taken as varied: design resistance of the material, wall and shelf dimensions. Regulatory (local stability of the wall and shelf profiles of the column) and structural limitations (the possibility of using welding equipment in the manufacture of the column) were taken into account. The following criteria were taken as criteria of the objective function: the cross-sectional area of the column, the moment of inertia of the cross-section in the plane of least rigidity, and the manufacturing cost.

Based on the solution of the problem of determining the bearing capacity, a technique is developed for optimizing the cross-sectional dimensions of a composite H-shaped eccentrically compressed welded bisteel columns, taking into account the elastoplastic properties of the material, initial defects and residual stresses in a geometrically and physically nonlinear setting under a given load [29].

4. Conclusion

1. A theoretical and experimental study of the operation of columns of steel of two grades with different yield strengths under static load was carried out. The method for determining the maximum loads makes it possible to rationally select economical sections in the form of a welded I-beam taking into account the required regulatory restrictions.

2. The results of analytical and numerical modeling of the stress-strain state and ultimate loads of the bisteel columns are in satisfactory agreement with the data of experimental studies.

3. The developed technique was used to solve the problem of multi-criteria, multi-parameter optimization of the cross-sectional dimensions of H-shaped columns with a high degree of sampling of the dimensions of the structure.

5. Acknowledgements

The reported study was funded by RFBR, project number 20-38-90056\20.

References

1. Bruneau, M., El-Bahey, S., Fujikura, S., Keller, D. Structural fuses and concrete-filled steel shapes for seismic and multi-hazard resistant design. Bulletin of the New Zealand Society for Earthquake Engineering. 2011. DOI: 10.5459/bnzsee.44.1.45-52
2. Bareišis, J., Kleiza, V. Effect of layer geometry and stiffness on the fields of normal stresses in multilayer beams under asymmetric bending. Mechanics of Composite Materials. 2009. DOI: 10.1007/s11029-009-9093-6

3. Jaras, A., Kačianauskas, R. Elastic-plastic analysis of bisteel i-section beams. *Statyba*. 2001. DOI: 10.1080/13921525.2001.10531713
4. Moiseev, V.I. Analysis of the stability of webs and flanges in bisteel beams with consideration of plastic deformation. *Journal of Constructional Steel Research*. 1992. DOI: 10.1016/0143-974X(92)90029-E
5. Dmitriev, V.G., Krasnovskiy, E.E., Salatov, E.K. Research of features of nonlinear deformation the bisteel beams using a finite element method. *Engineering physics*. 2009.
6. Liang, Y., Jeyapragasam, V.V.K., Zhang, L., Zhao, O. Flexural-torsional buckling behaviour of fixed-ended hot-rolled austenitic stainless steel equal-leg angle section columns. *Journal of Constructional Steel Research*. 2019. DOI: 10.1016/j.jcsr.2018.11.019
7. Yang, L., Zhao, M., Gardner, L., Ning, K., Wang, J. Member stability of stainless steel welded I-section beam-columns. *Journal of Constructional Steel Research*. 2019. DOI: 10.1016/j.jcsr.2018.12.022
8. Liu, J., Zhou, T., Lei, Z., Chen, X., Chen, Z. Eccentric compression performance of slender L-shaped column composed of concrete-filled steel tubes connected by steel linking plates. *Journal of Constructional Steel Research*. 2019. DOI: 10.1016/j.jcsr.2019.06.012
9. Yang, B., Shen, L., Kang, S.B., Elchalakani, M., Nie, S.D. Load bearing capacity of welded Q460GJ steel H-columns under eccentric compression. *Journal of Constructional Steel Research*. 2018. DOI: 10.1016/j.jcsr.2018.01.011
10. Liu, Y., Chantel, S. Experimental study of steel single unequal-leg angles under eccentric compression. *Journal of Constructional Steel Research*. 2011. DOI: 10.1016/j.jcsr.2011.02.005
11. Sun, Y.B., Cao, T.J., Xiao, Y. Full-scale steel column tests under simulated horizontal and vertical earthquake loadings. *Journal of Constructional Steel Research*. 2019. DOI: 10.1016/j.jcsr.2019.105767
12. Jiang, J., Ye, Z.J., Bao, W., Wang, X., Wang, Y.B., Dai, X.H. Flexural buckling behaviour of 690 MPa high strength steel H-section columns. *Engineering Structures*. 2019. DOI: 10.1016/j.engstruct.2019.109718
13. Liu, Y., Hui, L. Experimental study of beam-column behaviour of steel single angles. *Journal of Constructional Steel Research*. 2008. DOI: 10.1016/j.jcsr.2007.11.002
14. Bu, Y., Gardner, L. Finite element modelling and design of welded stainless steel I-section columns. *Journal of Constructional Steel Research*. 2019. DOI: 10.1016/j.jcsr.2018.03.026
15. Wang, Y.B., Li, G.Q., Chen, S.W., Sun, F.F. Experimental and numerical study on the behavior of axially compressed high strength steel columns with H-section. *Engineering Structures*. 2012. DOI: 10.1016/j.engstruct.2012.05.018
16. Iljashenko, A.V. About eccentric compression of thin-walled bars composed of initially curved finned elements. *International Journal for Computational Civil and Structural Engineering*. 2008. Vol. 4. Issue 1. Pp. 71–74.
17. Vorontsov, G.V., Petrov, I.A., Alekseev, S.A. Stiffness matrices of spatially loaded non-linearly deformable rods. Part 2. *News of higher educational institutions. North Caucasus region. Series: Engineering*. 2008. No. 4. Pp. 68–72.
18. Lalin, V.V., Rozin, L.A., Kushova, D.A. Variational functionals for two-dimensional equilibrium and stability problems of Cosserat-Timoshenko elastic rods. *Magazine of Civil Engineering*. 2013. 36(1). Pp. 87–96. DOI: 10.5862/MCE.36.11
19. Lalin, V.V., Zdanchuk, E.V., Kushova, D.A., Rozin, L.A. Variational formulations for non-linear problems with independent rotational degrees of freedom. *Magazine of Civil Engineering*. 2015. 56(4). Pp. 54–65. (rus). DOI: 10.5862/MCE.56.7
20. Przybylski, J., Kuliński, K. Shape enhancement of an eccentrically loaded column using piezoelectric actuator. *Engineering Structures*. 2019. DOI: 10.1016/j.engstruct.2018.07.014
21. Pastor, M.M., Roure, F. Open cross-section beams under pure bending II. Finite element simulation. *Thin-Walled Structures*. 2009. DOI: 10.1016/j.tws.2008.10.021
22. Bu, Y., Gardner, L. Laser-welded stainless steel I-section beam-columns: Testing, simulation and design. *Engineering Structures*. 2019. DOI: 10.1016/j.engstruct.2018.09.075
23. Volkova, V.E., Makarova, A.A. Numerical modeling of the stress-strain state of a beam with a flexible wall. *Metal constructions*. 2012. No. 4(17). Pp. 261–269.
24. Sokolovsky, Z.N., Kholkin, E.G. Determination of the bearing capacity of thin-walled structures taking into account local stability loss. *Bulletin of the Siberian State Automobile and Highway Academy*. 2013. No. 3(31). Pp. 93–96.
25. Zarifyan, A.Z., Petrov, I.A. Determination of the optimum sizes of cross section compressed H-shaped bisteel columns. *Easy building constructions*. 1999.
26. Petrov, I.A. Optimization of sections of eccentrically compressed bistal columns: dissertation of a candidate of technical sciences: 05.23.17. Novochoerkassk, 2000. 175 p.
27. Petrov, I.A., Shkurakov, L.V. Bearing capacity of is central-compressed double-T column. Improvement of calculation, design and production of building constructions. 1995.
28. Skibin, G.M., Shutova, M.N., Evtushenko, S.I., Chutchenko, I.A. Reliability increase of running gears elements of mining traction locomotives using finite-element analysis package. *IOP Conference Series: Earth and Environmental Science*. 2017. DOI: 10.1088/1755-1315/87/2/022021
29. Evtushenko, S.I., Petrov, I.A., Alexeev, S.A. Optimization task when calculating the bi-steel thin-walled rod. *AIP Conference Proceedings*. 2019. DOI: 10.1063/1.5138445

Contacts:

Sergej Evtushenko, evtushenkosi@mgsu.ru

Igor Petrov, iap6691@gmail.com

Marina Shutova, shutovapublish@mail.ru

Boris Chernykhovskiy, cbotms@gmail.com