



Research article

UDC 631.6.03

DOI: 10.34910/MCE.125.9



## Pilot installation of a biosorption facility on a rice irrigation system

V.A. Suprun, V.V. Ustinova 

*Federal Scientific Centre of Agroecology, Complex Melioration and Protective Afforestation of the Russian Academy of Sciences, Volgograd, Russian Federation*

 [ustinova-v@vfanc.ru](mailto:ustinova-v@vfanc.ru)

**Keywords:** water quality, mineralization, water purification, drainage and waste water, bioengineering technology, sorbents, bioplateau

**Abstract.** The article presents the composition and design of the developed biosorption facility designed to purify drainage and waste water from rice irrigation systems. The object of the study is the Sarpin watering and irrigation rice System (SWIS) located in the semi-desert zone of the Republic of Kalmykia. The studies were conducted and tested in field and laboratory conditions. The composition of the biosorption facility should include at least four stages of purification. The main elements of the biosorption facility design are a settling tank (section 1), a filtration chamber filled with medium-sized crushed stone (20–40 mm) and NDP-600 diatomite powder (section 2), as well as a bioplateau complex (section 3) and a filter chamber with a mixture of sorbents (section 4). The parameters of the bioplateau were calculated and its design was improved by including dampers that provide the necessary contact time of the treated water with higher aquatic vegetation on a smaller area of the structure, increasing the efficiency of purification. A graphical model of the structure was created in the AutoCAD program. Also, the project of the biosorption facility module developed in AutoCAD made it possible to calculate the volume of earthworks and implement them on the SWIS in the Republic of Kalmykia.

**Funding:** The study was carried out within the framework of state assignment No. FNFE 2022-0004 “Reclamation complexes: assessment, condition monitoring and process management using digital technologies.”

**Citation:** Suprun, V.A., Ustinova, V.V. Pilot installation of a biosorption facility on a rice irrigation system. Magazine of Civil Engineering. 2024. 17(1). Article no. 12509. DOI: 10.34910/MCE.125.9

### 1. Introduction

To date, the Sarpin watering and irrigation rice system (SWIS) and part of the Kalmyk-Astrakhan irrigation rice system (KARIS) are major reclamation facilities. For this period of time, their total irrigation area is 50.9 thousand hectares, of which 14.9 thousand hectares (SWIS) and 8.5 thousand hectares (KARIS) are regular irrigation, and the rest of the area falls on estuaries [3]. The Sarpin (SWIS) and Kalmyk-Astrakhan (KARIS) systems are geographically located in the north-east of the Republic of Kalmykia. The soils are represented by light chestnut and brown semi-desert, in combination with salt pans. Water supply is carried out from the Volga River in the Volgograd and Astrakhan regions. On its shore there are two water intakes of machine water lifting – Raygorodsky (near the village of Raygorod, Volgograd region) and Ushakovsky (near the village of Ushakovka, Astrakhan region). Water supply is carried out through the channels P-1 with a length of 114.6 km, P-3 118.8 km, taking into account the channel BP-1 and the Connecting channel 9.7 km. The systems were designed for rice crop rotation.

In 2010, 14.8 thousand hectares of land were not regularly irrigated. On the KARIS, the area of reclaimed land is 8.5 thousand hectares, but today only 0.5 thousand hectares are irrigated. About 30 % of the lands on the studied systems initially already had an unsatisfactory condition in terms of land reclamation due to the increased proportion of salinity of the root zone and groundwater regime [2].

Over the past 10–15 years, there has been a decrease in part of the sown areas of rice, and the dynamics of grain and fodder cultures has increased, but their yield is not high. It is necessary to radically revise the model of cultivation of agricultural crops, their cultivation technologies in order to use irrigated land more efficiently on the studied systems, as well as to introduce water-saving technologies and purification methods for reuse of waste drainage waters [3].

Research and development of purification methods for mineralized drainage and waste water were done by S.Y. Bezdina, I.V. Glazunova, L.V. Kireicheva, E.V. Ovchinnikova, K.Yu. Rybka, L.I. Shelepova, N.M. Segalove and many others [4–11]. N.P. Andreeva's works are devoted to the research of sorption materials for wastewater and drainage water treatment [12–15] etc. The reuse of drainage and waste water from rice irrigation systems was carried out by J.V. Kizyun, V.V. Lysenko, N.V. Ostrovsky, A.N. Semenenko [16–18] etc. Based on the results of the conducted research, the possibility of using natural materials as sorbents for purification and desalination of drainage and waste water has been scientifically substantiated. Application of local salt-absorbing plants could also be useful.

It is also necessary to reduce the mineralization indicators to the standard values of irrigation water by reducing the content of the main ions, as well as to achieve a balance of the ratio of calcium and sodium. For this purpose, an additional design element of a bioengineered sorption facility is needed. The previous studies showed that for more effective purification and desalination, such sorbents as agroionite and diatomite can be used, together with local higher aquatic plants (HAP) such as common sedge (*Carex nigra*) and broad-leaved cattail (*Typha latifolia*). The above-mentioned sorbents in combination with HAP have shown the most effective results in the purification and desalination of drainage and waste water in a model experiment [23].

Thus, the purpose of the presented research is to develop the composition and design of a new biosorption facility for the purification and desalination of waste drainage waters from rice irrigation systems. A gabion open gravity filtration treatment facility, which provides the purification of stormwater from highways, was used as a prototype. In addition, a bioplateau and a special chamber with artificial sorption materials was added to the facility. Depending on the set of pollutants, higher aquatic plants and sorption materials were selected. In connection with the purpose of the research, the objectives of the study were: calculation of the parameters of the bioplateau using a computer program; calculation of the parameters of the sorption chamber and the irreducible volumes of sorbents in the biosorption facility; designing a biosorption facility module using the AutoCAD program.

## 2. Methods

### 2.1. The Sarpin irrigation system

In the Sarpin irrigation system (SWIS), water intake from the Volga River in 2022 amounted to 57538 million m<sup>3</sup> per year, and the discharge of drainage and waste water from the rice irrigation system to the Sarpa Lake amounted to about 17 million m<sup>3</sup> per year. The main place of accumulation of drainage and discharge waters is Sarpa Lake. The water in the Sarpa lake has an increased level of mineralization and is a water discharge of drainage and waste water (up to 200 million m<sup>3</sup>) from rice irrigation systems of the Sarpinsk lowland. Depending on the discharge volume from 10 to 30 million m<sup>3</sup>, the salinity ranges from 7.5 to 15 grams per liter, containing significant concentrations of sodium chloride and neutral activity (pH < 8.0) [19]. The dynamics of water intake, discharge of drainage and wastewater and the area of rice cultivation on SWISS are shown in Table 1.

**Table 1. Dynamics of water intake, discharge of drainage and waste water into Sarpa Lake and the area of rice sowing (data from the October RMO RK).**

Year	2011	2012	2013	2014	2015	2016	2017	2018	2019	2020	2021	2022
Water intake, thousand m <sup>3</sup>	-	-	-	-	-	-	78973	69246	101338	70319	105562	57538
Discharge into Sarpa Lake, thousand m <sup>3</sup>	30871	18904	26510	14523	12096	13968	14902	13871	17214	20732	18618	16859
The area occupied by rice, thousand m <sup>3</sup>	3560	4656	51456	4005	3251	3201	3270	3300	4290	2955	3626	2717

During rice irrigation by flooding, the mineralization of drainage and waste water increases almost twice (from 0.9 to 1.7 grams per liter). The type of water by chemical composition is sodium chloride. By the end of the growing season, as well as during non-vegetative periods, mineralization increases to 6.0–7.0 grams per liter with a significant predominance of chloride sulfate and sodium ions. Thus, such indicators can lead to deterioration of the condition of plants and salinization of the soil, and salinization processes can also occur due to the high pH (Table 2).

**Table 2. Chemical analysis of water in the discharge channel near the pumping station (HC-9).**

Season	Ion concentration, grams per liter							Sum of salts, grams per liter	pH
	CO <sub>2</sub> <sup>-</sup>	HCO <sub>3</sub> <sup>-</sup>	Cl <sup>-</sup>	SO <sub>4</sub> <sup>-</sup>	Ca <sup>++</sup>	Mg <sup>++</sup>	Na <sup>+</sup>		
Spring	0.01	0.49	0.9	1.90	0.41	0.20	0.83	4.74	8.3
Summer	-	0.27	0.17	2.66	0.32	0.22	0.69	4.34	8.2
Autumn	-	0.19	0.80	2.46	0.36	0.32	1.13	5.10	8.3

The quality of drainage and waste water was assessed and found unsatisfactory (Class III-IV) for irrigation with an irrigation coefficient of 5.33. The use of such water can cause the processes of salinization and alkalinization of the soil, and an increase in pH, especially when growing crops on heavy soils, thus negatively affecting the crop yield [20]. The possibility of using this water for irrigation will partially solve the problem of lack of water resources and thus reduce the cost of rice [21]. A necessary condition is the removal of chloride and sodium ions from the water and an increase in the amount of calcium, which will improve the irrigation coefficient and prevent further deterioration of the quality of water resources. To do this, it is necessary to develop a bioengineering technology that could purify mineralized runoff contaminated with nutrients and partially desalinate water. The technology should be low-energy, as natural as possible, easy to maintain and should not require large financial investments in order to become economically viable.

## 2.2. The water treatment facility

As a prototype of the developed technology, an installation created by ECOLANDSCHAFT-XXI CENTURY LLC for the purification of stormwater, rainwater and meltwater from urban highways was chosen. According to their design features, these are gabion open gravity treatment filtration facilities, including a bioplateau and a special chamber with artificial sorption materials. Such structures aesthetically fit into the infrastructure of the city and have an attractive appearance [22].

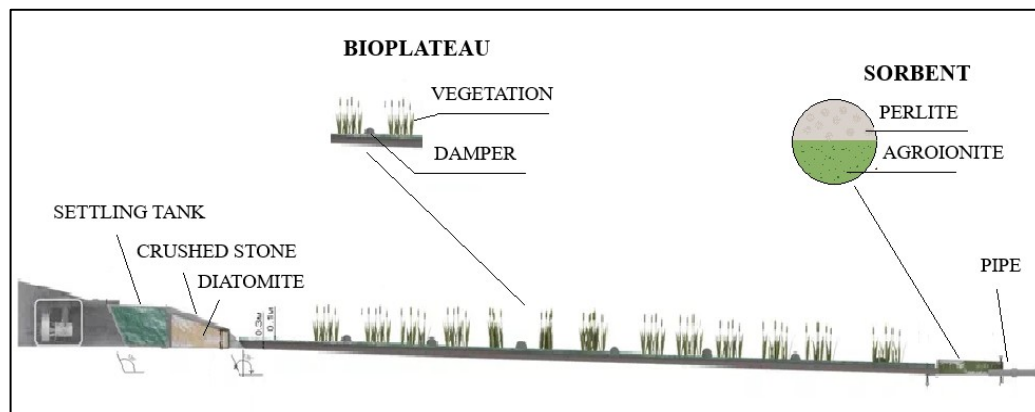

**Figure 1. The main elements of the biosorption facility design (profile).**

## 3. Results and Discussion

The composition of the biosorption facility should include at least four stages of purification. The main elements of the biosorption facility design are a settling tank (section 1), a filtration chamber filled with medium-sized crushed stone (20–40 mm) and NDP-600 diatomite powder (section 2), as well as a bioplateau complex (section 3) and a filter chamber with a mixture of sorbents (section 4) (Fig. 1).

The parameters of the section with a complex bioplateau were partially adjusted from the initial project of installation of ECOLANDSCHAFT-XXI CENTURY LLC after the choice of the construction site.

The construction site of the biosorption facility had to be chosen directly next to the 18xc3 discharge channel on the SWIS. In this section, the width of the structure had to be reduced. In order to reduce the width of the bioplateau and at the same time adjust the flow rate, special earthen zigzag mounds (dampers) were invented, thanks to which water moves longer on a smaller area of the bioplateau, thus the speed of movement is regulated and the flow time through the bioplateau increases. The calculated value of the bioplateau parameters was: length – 50 m, width – 3 m, water layer height – 0.3 m.

The modular installation for the SWIS was designed for a water consumption of 2.4 m<sup>3</sup> per day.

The parameters of the biosorption facility were justified using existing techniques [22, 25] and preliminary results of field and laboratory studies. The parameters were calculated for the main structural elements of the biosorption facility.

The calculation of the settling tank is carried out based on its performance, that is, the volume of clarified water per unit of time. It is necessary that the water entering the sump should remain at rest for a certain period of time, in order to deposit the smallest suspended fraction to the bottom of the sump. Based on this, the depth was taken as 2.5 m, and the particle settling rate (1 m/hour) was calculated according to [27].

The settling time  $t$  can be expressed in terms of the path  $H$  of the particles and their velocity  $w$  :

$$t = \frac{H}{w} = \frac{2.5}{1} = 2.5 \text{ hours.} \quad (1)$$

The performance of the sump ( $V_{lighten}$ , m<sup>3</sup> per s) of periodic action is calculated by the formula:

$$V_{lighten} = \frac{V}{t} = \frac{S * H}{t} = \frac{18.75}{2.5} = 7.5 \text{ m}^3/\text{hour}, \quad (2)$$

where  $V_{lighten}$  is the volume of clarified liquid at the outlet of the settling tank, m<sup>3</sup>;  $H$  is the height of the clarified liquid layer, m;  $S$  is the surface area of settling, m<sup>2</sup>;  $t$  is the separation time (settling), h. Data according to [27].

Thus, the capacity of the sump for a modular installation in this case was 7.5 m<sup>3</sup>/h.

Calculations have shown that the performance of settling tanks depends only on the particle deposition rate and the deposition surface area.

Based on the calculations performed, the model installation of the biosorption facility has the following dimensions (Table 3).

**Table 3. Parameters of the model installation of a biosorption facility.**

Cleaning stage	$L$ (m)	$B_1$ (m)	$B_2$ (m)	$H_1$ (m)	$H_2$ (m)
Accumulating sump	5	2.5	3.3	2.5	1
Chamber with sand and diatomite powder NDP-600	0.5	3	3.3	1	0.9
Complex bioplateau	50	3	3.3	0.5	0.3
Chamber with a mixture of sorbents (agroionite + perlite agrotechnical)	0.4	3	3.3	0.5	0.4
Total, (max)	55.9	Max=3	Max=3.3	Max=2.5	Max=1

Based on the table  $L$  is the length;  $B_1$  is the width of the lower base;  $B_2$  is the width of the upper base;  $H_1$  is the height of the section at the water inlet;  $H_2$  is the height of the section at the water outlet.

The functionality of a biosorption facility for water purification consists of the following stages. Drainage water is pumped from the discharge channel by a pump into a special settling tank. Suspended particles are deposited here, water is collected and accumulated. The flow rate of drainage and waste water in biosorption facility treatment can be from 1 l/s to 100 l/s and higher, depending on the size of the structure and, as necessary, is determined by the filtration flow rate through the filter elements. To determine the required sorbent loading mass, the dynamic exchange capacity (DEC) should be calculated. This is the amount of ionic particles absorbed by the sorbent at the moment when the solution is filtered through the sorbent layer until the so-called "breakthrough" moment. Thus,  $C_{exit}$  is the minimum permissible concentration in each specific case, or the minimum detectable concentration determined by the available

analyzer, or the required maximum permissible concentration (MPC) for a specific technological process. This level of concentration is called "breakthrough".

During laboratory studies, the moment of the "breakthrough" was recorded under dynamic conditions using such suitable sorbents as NDP-600 diatomite ("KVANT" production company) and a mixture of agrotechnical sorbents agroionite + perlite in three repetitions at the simulated salinity level of the solution (5 g/l). Certain samples of sorbents were placed in the filtration column and water was supplied until the value of the indicators of total mineralization began to grow. In total, 20 liters of the simulated solution were passed in each variant. The mass of the sorbent was selected based on the volume (100 ml) and was 7.5 g for NDP-600 diatomite, and 4.5 g for the agroionite + perlite mixture. The indicators of total mineralization were measured every 0.5 liters of the volume of the solution passed through the filtration column. The results of the study in the form of a graph of average indicators are presented in the figure (Fig. 2).

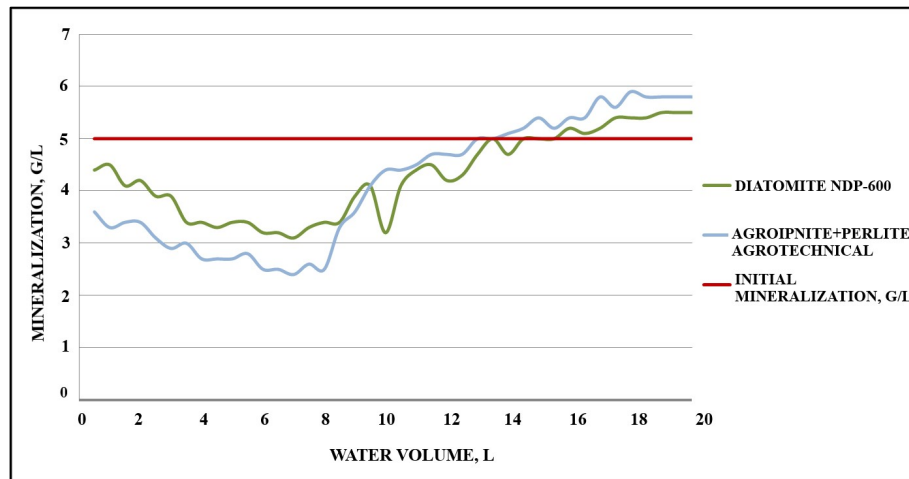

Figure 2. Output sorption curves.

The graph shows that NTP-600 diatomite in a volume of 100 ml is effective for cleaning 10 liters of saline solution with mineralization of 5 g/l, then the mineralization index of the filtrate begins to grow. After skipping 15.5 liters of solution, the mineralization index of the filtrate becomes higher than the initial one.

Based on the data obtained, the dynamic exchange capacity (DEC) of the studied sorbents before the breakthrough can be calculated according to the following formula (A.A. Komissarenkov) [24]:

$$DEC = \frac{1}{g} * \sum \left( \frac{C_{exit}}{C_0} \right) [(C_0 - C_{exit}) * V] \quad (3)$$

based on the formula,  $g$  is the mass of the sorbent;  $C_0$  is the initial concentration of the ion, grams per liter;  $C_{exit}$  the concentration of the ion at the outlet of the column, grams per liter;  $V$  is the volume of filtrate with a concentration of  $C_{exit}$ , liter.

As a result of a laboratory experiment,  $C_{exit}$  and  $V$  were found for the sorbent diatomite NDP 600, for a mixture of sorbents agroionite + perlite, and  $C_0 = 5$  g per l.

The DEC calculation for NDP-600 Diatomite is as follows:

$$DEC_D = \frac{1}{7.5g} * \sum \frac{C_{exit}}{C_0} [(5g/l - 3.2g/l) * 10l] = \frac{18}{7.5} = 2.4g/g. \quad (4)$$

3.2 grams per liter is the concentration of salt at the outlet of the filtration column obtained during laboratory tests.

Thus, it can be concluded that 1 g of the sorbent diatomite NDP-600 absorbs 2.4 g of salt.

Also, the calculation of DEC for a mixture of sorbents agroionite + perlite agrotechnical ( $DEC_{A+P}$ ) is 4.4 g per 1 g of the mixture. This value is due to the porosity of the resulting sorbent mixture and different sorption mechanisms of the components of the mixture.

In order to calculate the required mass of the sorbent, it is necessary to know the period at which it is possible to return water to the irrigation channel and use it for irrigation in the future. It took 100–120 days to complete the processes of rice reproduction in the conditions of the desert zone of the Republic of

Kalmykia, provided that the average sum of active temperatures was 3400–3600 °C (according to the research data of E.B. Dedova, R.M. Shabanov) [22]. Thus, drainage and waste water can be returned to the irrigation canal for further use within 50–60 days.

The mass of the sorbent was calculated for 21 days. Based on the data obtained and the planned experimental installation with a flow rate of 2.4 m<sup>3</sup>/day, it is possible to calculate the mass of the sorbent for each section required for purification.

To substantiate the parameters of the sorption chamber, it is necessary to calculate the mass of sorbents. Based on the results of laboratory studies aimed at studying the static and dynamic capacity of sorbents. The mass of sorbents is calculated according to the following formulas. 10 % of the total mass was added to the resulting mass, as a margin of error (flushing, blowing, scattering).

Based on this, the mass of the sorbent for NDP-600 ( $m_d$ ) diatomite powder in the second section will be equal to:

$$m_d = \frac{7.5g * 100l}{10l} * 24 * 21 = 37800g = 37.8 kg. \quad (5)$$

Similarly, for the fourth section with a complex sorbent (agroionite + perlite agrotechnical ( $m_{a+p}$ )) the mass of the sorbent is 28.3 kg.

10 liters is the volume of saline solution that purification 7.5 grams of sorbent. The water consumption of the modular sorption plant, built in the field, is 100 liters per hour.

To develop a biosorption facility project, it was necessary to analyze the existing methods of calculating the bioplateau and sorption elements in order to calculate the necessary parameters of the sections of the biosorption facility module. The calculation was performed according to the standard method of V.G. Magomedov [25, 26].

Principles of bioplateau design. When designing a bioplateau, the main task of which is to remove biogenic bioplateau elements from the treated water, the contact time of water ( $t$ , day) with the HAP is calculated according to the dependencies (6) or (7):

$$t = \frac{27(\ln C_i - \ln C_e + \ln F)}{1.1^{T-20}} \quad (6)$$

or

$$t = \frac{\ln C_i - \ln C_e + \ln F}{65K_T}, \quad (7)$$

where  $C_i$  is the concentration of the biogenic substance at the entrance of the bioplateau, mg per l;  $C_e$  is the required concentration at the exit from the bioplateau, mg per l;  $F$  is the fraction of the substance attributable to water-soluble compounds, expressed as the ratio of the water-soluble substance to the total content, in fractions of one;  $T$  is the water temperature, °C;  $K_T$  is reaction rate constant (depends on the chemical composition of effluents and temperature), 1 per day;  $K_T$  is 0.0057 per day.

Then the area of the bioplateau ( $A$ ) is calculated according to the dependence:

$$A = \frac{t}{d \frac{n}{Q}}, \quad (8)$$

where  $t$  is the contact time, day;  $d$  is the depth of water in the bioplateau, m;  $n$  is the ratio of the volume occupied by water to the total volume of water and plants, a fraction of one [22].

The dimensions of the biosorption facility model installation have the following indicators (Table 3):

After calculating the parameters of the structure, a graphical model of the structure was created in the AutoCAD program (Fig. 3).

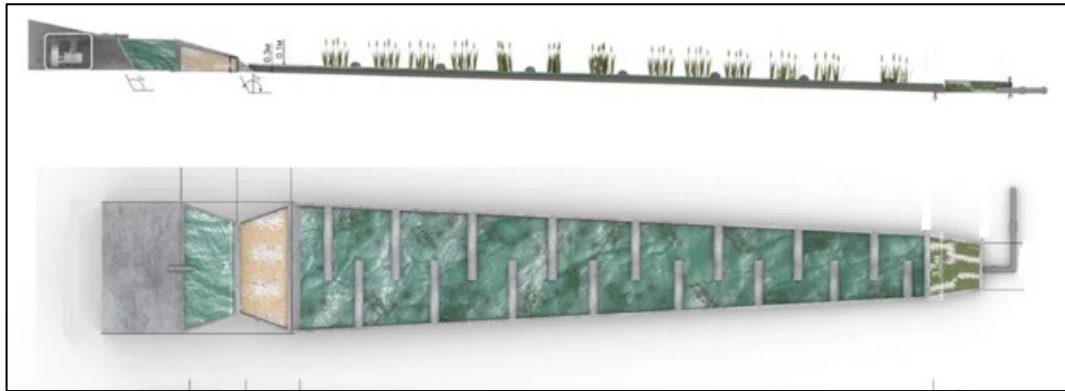

**Figure 3. Visualization of the biosorption facility for the purification of drainage and waste water.**

The project of the biosorption facility module developed in AutoCAD made it possible to calculate the scope of work and implement it on the SWIS in the Republic of Kalmykia.

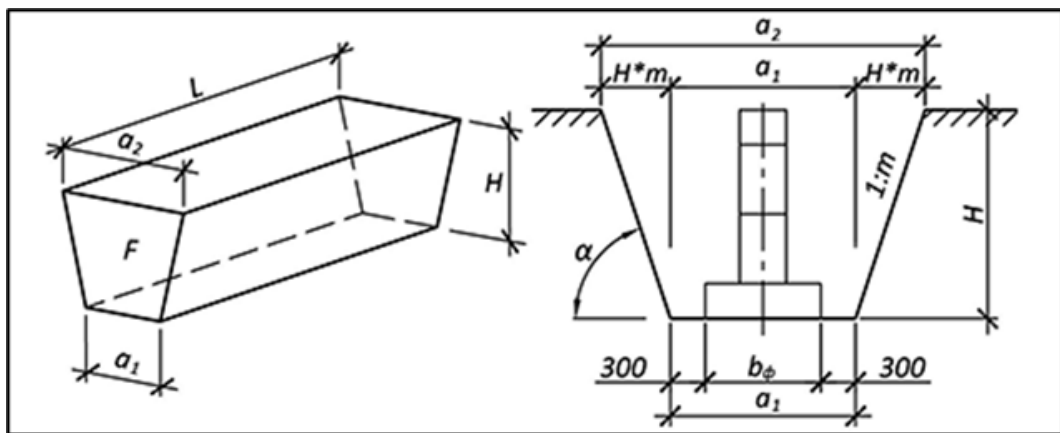

**Figure 4. The scheme of the biosorption facility for calculating the volume of excavation of the trench.**

To calculate earthworks, the following parameters are required: type of soil, width of the trench base ( $a_1 = 3$ ), width of the trench top ( $a_2 = 3.3$ ), trench height ( $H_1 = 2$ ), trench height ( $H_2 = 0.3$ ), trench length ( $L = 55.9$ ) (Table 3).

The cross-sectional area of the recess ( $F_1$ ) is  $8 \text{ m}^2$ , the cross-sectional area ( $F_2$ ) =  $0.945 \text{ m}^2$ , then the volume of the recess ( $V$ ) will be:

$$V = (F_1/2 + F_2/2 - m * (H_1 - H_2) 2/6) * L =$$

$$= (8/2 + 0.945/2 - m * (2 - 0.3) 2/6) * 55.9 = 236.55 \text{ m}^3. \quad (9)$$

The excavation work was carried out by a two-bucket excavator loader TEREX TLB 825-RM, with the assistance of the Sarpin branch of the Federal State Budgetary Institution "Kalmeliiovodkhoz Management". After that, the slopes were leveled and earthen ramparts were built at the bottom of the structure in a section designed to create bioplateau that act as dampers. Plastic pipes were laid on the earthen ramparts to strengthen the dampers and create the required height without expanding the base. 22 such dampers were built, alternately on the left and right sides of the base, 1 m long and 1.5 m wide.

The calculation of the settling tank (first section) was performed based on the required volume of clarified water. The second section, intended for the sorbent, was filled with a natural mineral sorbent – NDP-600 diatomite powder. Since this sorbent is used in powdered form and is washed out very quickly with water, a washed layer of crushed stone of medium fraction (20–40 mm) was placed over the sorbent so that 25–30 cm remained to the surface. A mixture of mineral sorbents (agroionite + agrotechnical perlite) was poured into the fourth section and thoroughly mixed to enhance the operation of various sorption mechanisms.

After the construction of the structure, plants were transplanted into the bioplateau section. The necessary plants were manually dug out in an irrigation canal, transferred to a bioplateau and planted. It was necessary to do this in a short time so that the aquatic plants would not lose their viability.

#### 4. Conclusion

1. The composition and design of a new biosorption facility for the purification and desalination of drainage and waste water (DWW) from rice irrigation systems was developed. Its prototype was a gabion open gravity filtration treatment facility, which provides the purification of stormwater from highways. A feature of the developed biosorption facility distinguishing it from the prototype is the possibility, along with the removal of biogenic substances, to carry out partial desalination of mineralized DWW, which requires the inclusion of an additional chamber with a complex sorbent, justified in relation to the quality of the treated water. The main elements of the biosorption facility design are a settling tank (section 1), a filtration chamber filled with medium-sized crushed stone (20–40 mm) and NDP-600 diatomite powder (section 2), as well as a bioplateau complex (section 3) and a filter chamber with a mixture of sorbents (section 4).
2. The parameters of the bioplateau were calculated using a computer program [28] and its design was improved by including dampers that provide the necessary contact time of the treated water with the HAP to increase the cleaning efficiency. This allows reducing the area of the bioplateau without compromising its cleaning ability.
3. When calculating the parameters of the sorption chamber and the required volumes of sorbent in the biosorption facility, it was decided to calculate the mass of the sorbent according to the sorption capacity determined in laboratory and field studies.
4. The design of the biosorption facility module was carried out using the AutoCAD program, according to the previously calculated parameters, which made it possible to justify the amount of excavation work. A model of a biosorption structure in 3D space was compiled, which makes it possible to visually represent the type of the projected structure in full scale.

#### References

1. Dedova, E.B., Sazanov, M.A., Kovrigo, S.I. Kharakteristika vodnykh resursov Respubliki Kalmykiya i puti ikh ratsionalnogo ispolzovaniya dlya nuzhd agropromyshlennogo kompleksa. Materialy mezhdunarodnoi nauchnoi konferentsii «Ekologicheskoye sostoyaniye prirodnoy sredy i nauchno-prakticheskiye aspekty sovremennykh meliorativnykh tekhnologiy» [Characteristics of water resources of the Republic of Kalmykia and ways of their rational use for the needs of the agro-industrial complex. Mat. international scientific conference "Ecological state of the natural environment and scientific and practical aspects of modern reclamation technologies"]. Tom 6. Ryazan. 2014. Pp. 256–260. (rus)
2. Dedova, E.B., Sazanov, M.A. Problemy vodnogo khozyaystva Respubliki Kalmykiya v svyazi s razvitiyem melioratsii. Sovremennoye sostoyaniye i perspektivy razvitiya vodokhozyaystvennogo kompleksa Zapadno-Kaspiyskogo basseynovogo okruga: Vserossiyskaya nauchno-prakticheskaya konferentsiya [Problems of water management of the Republic of Kalmykia in connection with the development of land reclamation. Current state and prospects of development of the water management complex of the West Caspian Basin district: collection of articles of the All-Russian Scientific and Practical Conference]. Makhachkala: ALEF, 2013. Pp. 25–29. (rus)
3. Borodychev, V.V., Dedova, E.B., Chimidov, S.N. Rice cultivation under periodic surface irrigation in the Sarpinskaya Lowland. Plodorodie. 2013. 2. Pp. 35–37. (rus)
4. Bezdina, S.Ya. Ekologicheskie osnovy vodopolzovaniya [Ecological bases of water use]. Moskva. Vserossiyskiy nauchno-issledovatel'skiy institut agroximii imeni D.N. Pryanishnikova. 2005. 223 p. (rus)
5. Kireicheva, L.V., Glazunova, I.V. Environmentally friendly resources. Technical solutions for wastewater treatment. Voda Magazine. 2008. 4. Pp. 44–47. (rus)
6. Miroshin, M.A., Glazunova, I.V. Uchet predotvrashchennykh ushherbov pri raschete parametrov bioinzhenernykh sooruzhenij. Problemy kompleksnogo obustrojstva texnoprirodnnykh sistem. Materialy mezhdunarodnoj nauchno-prakticheskoy konferentsii [Taking into account the prevented damages when calculating the parameters of bioengineering structures. Problems of complex arrangement of technoprirodic systems: Materials of the International scientific and practical conference]. Moskva. 16–18 aprelya. 2013. Tom Chast' IV. Moskva. Moskovskij gosudarstvennyj universitet prirodoobustrojstva. 2013. Pp. 193–198. (rus)
7. Kontseptsiya razvitiya melioratsii sel'skokhozyaystvennykh zemel Respubliki Kalmykiya na period do 2020 goda [The concept of development of agricultural land reclamation in the Republic of Kalmykia for the period up to 2020]. Moskva. Rossiyskaya akademiya sel'skokhozyaystvennykh nauk. 2012. 64 p. (rus)
8. Kireicheva, L.V. Drainage flow as an alternative water resource for irrigation. Melioration and water management. 2018. 4. Pp. 13–18. (rus)
9. Rybka, K.Yu., Shchegol'kova, N.M. Features of functioning of constructed wetlands in arid regions. Arid Ecosystems. 2021. 27(3). Pp. 103–110. DOI: 10.24411/1993-3916-2021-10170
10. Shchegolkova, N. M., Kharitonov, S.L., Rybka, K.Y., Semenov, M.V. Taxonomic and Functional Diversity of Microbial Communities as an Indicator of the Effectiveness of Water Treatment in Constructed Wetlands. Water Resources. 2020. Vol. 47, No. 6. Pp. 1020–1030. DOI 10.1134/S0097807820060111
11. Ovchinnikov, A.S. Denisova, M.A., Bocharnikov. Water treatment of surface water using a ferrite reagent. IOP Conference Series: Earth and Environmental Science, Stavropol, 29–30 oktyabrya 2021 goda. Stavropol. 2022. Pp. 012002. DOI 10.1088/1755-1315/996/1/012002



12. Andreeva, N.P. Ochistka stochnykh vod s primeneniym sorbentov prirodnoho proiskhozhdeniya. Shestoy mezhdunarodnyy kongress "Voda: ekologiya i tekhnologiya" [Wastewater treatment with the use of sorbents of natural origin. Sat. tr. of the 6<sup>th</sup> International Congress of ECWATECH-2004]. Moscow. June 1-4. 2004. t 2. 697 p. (rus)
13. Glazunova, I.V., Martynenko, N.P. Kompleksnyy sorbent dlya ochistki stochnykh vod ot nefteproduktov i tyazhelykh metallov [Complex sorbent for wastewater treatment; from petroleum products and heavy metals]. Agrokhimicheskiy vestnik. № 4. 2001. Pp. 38-39. (rus)
14. Kireicheva, L.V., Yashin, V.M., Ilinsky, A.V., Nguen, S.H. Detoxification of heavy-metal contaminated leached chernozems and ancient alluvial soils with the use of sorption materials. Russian Agricultural Sciences. 2009. T. 35. № 3. Pp/ 182-184.
15. Kireicheva, L.V., Kuptsova, A.A. Improving the quality of drainage water using natural sorbents. Melioration and water management. 1998. 1. Pp. 6–8. (rus)
16. Kizyun, Zh.V., Shishkin, V.O., Ostrovsky, N.V. Estimation of economic efficiency of the method of cultivation of rice with the reuse of drainage waters. Scientific Journal of KubSAU. 2014. No. 97. Pp. 310–320. (rus)
17. Ostrovsky, N.V. Regulirovaniye vodno-vozdushnogo rezhima pochv v protsesse povtornogo ispolzovaniya sbrosnykh vod risovykh system. Nauchnyye dostizheniya molodezhi Kubani : sbornik tezisev dokladov nauchnykh konferentsiy studentov i aspirantov v 1998-2000 gg., Krasnodar, 01 yanvarya 1998 goda – 31 2000 goda [Regulation of the water-air regime of soils in the process of reuse of waste water of rice systems. Scientific achievements of youth – Kuban: collection of abstracts of scientific conferences of students and postgraduates in 1998–2000, Krasnodar]. Tom Vypusk 1. Krasnodar: Kubanskiy gosudarstvennyy agrarnyy universitet imeni I.T. Trubilina. 2001. 47 p. (rus)
18. Semenenko, A.N., Lysenko V.V. Vodooborotnaya risovaya orositelnaya sistema [Water-circulation rice irrigation system. The works of the Cubist]. Trudy Kub SKhI. Vyp. 224(252). Krasnodar. 1983. Pp. 127-132. (rus)
19. Tekhnicheskiye usloviya TU 2164-006-03029859-2009 "Agroionit - neorganicheskiy sorbent dlya rekultivatsii pochv i poglotitel soley tyazhelykh metallov" [Technical specifications TU 2164-006-03029859-2009 "Agroionite – inorganic sorbent for soil reclamation and a heavy metal salt absorber."]. (rus)
20. Ovchinnikov, A.S., Borodychev, V.V., Dedova, E.B., Sazonov, M.A. Monitoring of water resources in Republic of Kalmykia and water use ecosystem problems in agricultural industrial complex. Izvestia of the Lower Volga Agro-University Complex. 2015. 3(39). Pp. 9–19. (rus)
21. Dedova, E.B., Borodychev, V.V., Shuravilin, A.V. Economic and land-reclamation estimate of irrigation systems at the Kalmykia Republic. Melioration and water management. 2011. 4. Pp. 11–13. (rus)
22. Dedova, E.B., Shevchenko, A.A., Dedov, A.A., Shabanov, R.M. Technological regulations for improving the ecological state and increasing fodder production on estuary irrigation systems of the Caspian Lowland. IOP Conference Series. Earth and Environmental Science. II International scientific and practical conference "Ensuring sustainable development in the context of agriculture, green energy, ecology and earth science". Smolensk. Russian Federation. 2022. Vol. 1045. P. 012174. DOI 10.1088/1755-1315/1045/1/012174.
23. Ulrich, B. Natural and anthropogenic components of soil acidification. Zeitschrift für Pflanzenernahrung und Bodenkunde. 1986. 149.. Pp. 702–717. DOI: 10.1002/jpln.19861490607
24. Komissarenkov, A. A., Suslov, V.A. Nanokompleksy v tekhnologii vodopodgotovki [Nanocomplexes in water treatment technology]. Vodoochistka. 2011. № 6. Pp. 41-44. (rus)
25. Kulsy, L. A. Strokach, R.R. Tekhnologiya ochistki prirodnykh vod [Technology of natural water purification]. Kiev: Vishcha shk. 1981. Pp. 150–185. (rus)
26. Metodika (osnovnyye polozheniya) opredeleniya ekonomicheskoy effektivnosti ispolzovaniya v narodnom khozyaystve novoy tekhniki, izobreteniy i ratsionalizatorskikh predlozheniy [Methodology (basic provisions) for determining the economic efficiency of using new equipment, inventions and rationalization proposals in the national economy]. Izdatelstvo Ekonomika. Moskva. 1977. 48 p. (rus)
27. Rekomendatsii po raschetu sistem sbora, otvoda i ochistki poverkhnostnogo stoka s zhilykh massivov, ploshchadok predpriyatiy i opredeleniyu usloviy yego sbrosa v vodnyye obyekty [Recommendations on the calculation of systems for collecting, diverting and cleaning surface runoff from residential areas, enterprise sites and determining the conditions for its release into water bodies]. Moskva: AO "NII VODGEO", 2014. 88 p. (rus)
28. Glazunova, I.V., Romashchenko, A.K., Tishina, K.A. Bioengineering structures and storages of local flowing of watersheds for a more efficient usage of water resources of river basins. Environmental Engineering. 2018. 2. Pp. 46–54. (rus)

#### **Information about authors:**

**Veronika Suprun, PhD of Technical Sciences**

E-mail: [suprun-v@vfanc.ru](mailto:suprun-v@vfanc.ru)

**Viktoriya Ustinova,**

ORCID: <https://orcid.org/0000-0001-6490-7072>

E-mail: [ustinova-v@vfanc.ru](mailto:ustinova-v@vfanc.ru)

*Received 29.05.2023. Approved after reviewing 30.12.2023. Accepted 30.01.2024.*